



<b>IEC 60601-1</b> <b>Medical electrical equipment</b> <b>Part 1: General requirements for basic safety and essential performance</b>	
<b>Report Reference No.</b> .....:	S143040.02
<b>Date of issue</b> .....	14 March 2016
<b>Total number of pages</b> .....	201
<b>CB Testing Laboratory</b> .....:	ITL (Product Testing) Ltd.
<b>Address</b> .....	1 Bat Sheva St., POBox 6117, Lod 7120101, Israel
<b>Applicant's name</b> .....:	Flight Medical Innovations Ltd.
<b>Address</b> .....	Hatnufa 7, Petach Tikva 4951025, Israel
<b>Test specification:</b>	
<b>Standard</b> .....	IEC 60601-1: 2005 + CORR. 1 (2006) + CORR. 2 (2007)
<b>Test procedure</b> .....:	PM120
<b>Non-standard test method</b> .....:	N/A
<b>Test Report Form No.</b> .....:	IEC60601_1G
<b>Test Report Form Originator</b> .....	Underwriters Laboratories Inc.
<b>Master TRF</b> .....	Dated 2011-11
<p><b>Copyright © 2011 IEC System for Conformity Testing and Certification of Electrical Equipment (IECEE), Geneva, Switzerland. All rights reserved.</b></p> <p>This publication may be reproduced in whole or in part for non-commercial purposes as long as the IECEE is acknowledged as copyright owner and source of the material. IECEE takes no responsibility for and will not assume liability for damages resulting from the reader's interpretation of the reproduced material due to its placement and context.</p> <p>If this Test Report Form is used by non-IECEE members, the IECEE/IEC logo shall be removed</p> <p><b>This report is not valid as a CB Test Report unless signed by an approved CB Testing Laboratory and appended to a CB Test Certificate issued by an NCB in accordance with IECEE 02.</b></p>	
<b>Test item description</b> .....	Lung Ventilator
<b>Trade Mark</b> .....	
<b>Manufacturer</b> .....:	Same as applicant
<b>Model/Type reference</b> .....:	Flight 60 Blower
<b>Ratings</b> .....	100-240Vac, 50-60Hz, 1.25A max.; 12-15Vdc, 4.8A max.



<b>Testing procedure and testing location:</b>	
<input checked="" type="checkbox"/> <b>Testing Laboratory:</b>	ITL (Product Testing) Ltd.
<b>Testing location/ address .....</b>	1 Bat Sheva St., POBox 6117, Lod 7120101, Israel
<input type="checkbox"/> <b>Associated CB Test Laboratory:</b>	
<b>Testing location/ address .....</b>	
<b>Tested by (name + signature) ..</b>	Niv Reuven 
<b>Approved by (+ signature) .....</b>	Steli Loznen 
<input type="checkbox"/> <b>Testing procedure: TMP</b>	
<b>Tested by (name + signature) ..</b>	
<b>Approved by (+ signature) .....</b>	
<b>Testing location/ address .....</b>	
<input type="checkbox"/> <b>Testing procedure: WMT</b>	
<b>Tested by (name + signature) ..</b>	
<b>Witnessed by (+ signature) .....</b>	
<b>Approved by (+ signature) .....</b>	
<b>Testing location/ address .....</b>	
<input type="checkbox"/> <b>Testing procedure: SMT</b>	
<b>Tested by (name + signature) ..</b>	
<b>Approved by (+ signature) .....</b>	
<b>Supervised by (+ signature).....</b>	
<b>Testing location/ address .....</b>	
<input type="checkbox"/> <b>Testing procedure: RMT</b>	
<b>Tested by (name + signature) ..</b>	
<b>Approved by (+ signature) .....</b>	
<b>Supervised by (+ signature).....</b>	
<b>Testing location/ address .....</b>	



**List of Attachments (including a total number of pages in each attachment):**

Attachement #	Description	Pages
1	ND US + CA	8 (179 - 186)
2	Photos	14 (187- 200)
3	DC cable data	1 (201)

**Summary of testing**

**Tests performed (name of test and test clause):**

**Testing location:**

**Tests Report performed: S119640.02**

- 4.8; 4.9; 11.2; 15.4 Ratings on critical components
- 4.11 Power consumption (input) single phase and polyphase
- 5.9; 8.3 Determination of applied parts and accessible parts
- 7.1.2; 7.1.3 Durability and legibility of marking
- 8.6.6 Plugs, sockets
- 8.7.leakage current
- 8.8.3 Dielectric strength
- 8.9.4 Creepage distances and air clearances
- 9.4 Instability
- 11.1 Normal heating
- 11.8 Interruption of power supply
- 13.2.7 Impair of cooling

1 Bat Sheva St., POBox  
6117, Lod 7120101, Israel

**Summary of compliance with National Differences**

List of countries addressed: US and CA

X The product fulfils the requirements of \_\_IEC 60601-1:2005 3<sup>rd</sup> edition\_\_\_\_\_

**Copy of marking plate**

The artwork below may be only a draft. The use of certification marks on a product must be authorized by the respective NCBS that own these marks.

Flight 60 Blower

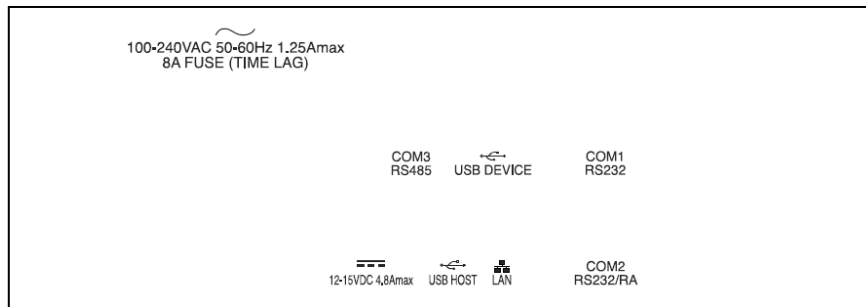
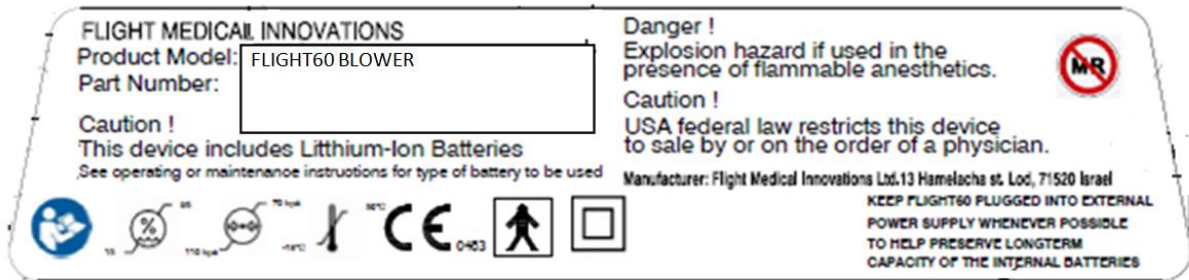

Ratings are specified Near to the Power in connectors:

- AC Connector
- 100 – 240 V AC, 50 - 60 Hz, 1.25A
- DC Connector
- 12 – 15 V DC, 4.8A



<b>GENERAL INFORMATION</b>	
<b>Test item particulars (see also Clause 6):</b>	
<b>Classification of installation and use .....</b>	transportable / portable / <del>stationary/</del> <del>mobile / fixed / permanently installed /</del> hand-held
<b>Device type (component/sub-assembly/ equipment/ system) .....</b>	Equipment
<b>Intended use (Including type of patient, application location) .....</b>	Portable Ventilator
<b>Mode of operation .....</b>	Continuous
<b>Supply connection .....</b>	<del>internally powered / permanently installed</del> / appliance coupler with detachable cord / <del>non-detachable cord</del>
<b>Accessories and detachable parts included .....</b>	Patient breathing circuit. Exhalation valve
<b>Other options include.....</b>	N/A
<b>Testing</b>	
<b>Date of receipt of test item(s) .....</b>	06/08/2014
<b>Dates tests performed.....</b>	10/08/2014 - 12/08/2014
<b>Possible test case verdicts:</b>	
- test case does not apply to the test object .....	: N/A
- test object does meet the requirement .....	: Pass (P)
- test object was not evaluated for the requirement .....	: N/E
- test object does not meet the requirement.....	: Fail (F)
<b>Abbreviations used in the report:</b>	
- normal condition .....	: N.C.
- means of Operator protection .....	: MOOP
- single fault condition.....	: S.F.C.
- means of Patient protection ...:	MOPP
<b>General remarks:</b>	
<p>"(see Attachment #)" refers to additional information appended to the report.          "(see appended table)" refers to a table appended to the report.          The tests results presented in this report relate only to the object tested.          This report shall not be reproduced except in full without the written approval of the testing laboratory.          List of test equipment must be kept on file and available for review.          Additional test data and/or information provided in the attachments to this report.</p>	
Throughout this report a <input type="checkbox"/> comma / x point is used as the decimal separator.	
<b>Manufacturer's Declaration per sub-clause 6.2.5 of IEC60601-1:</b>	



The application for obtaining a CB Test Certificate  Yes  
includes more than one factory location and a  Not applicable  
declaration from the Manufacturer stating that the  
sample(s) submitted for evaluation is (are)  
representative of the products from each factory  
has been provided .....

When differences exist; they shall be identified in the General product information section.

Name and address of factory (ies) ..... : Flight Medical Innovations Ltd.  
Hatnufa 7, Petach Tikva 4951025, Israel

## General product information:

### General product information and considerations:

The Lung Ventilator Flight 60 Blower is intended to provide continuous or intermittent mechanical ventilator support for the care of individuals who require mechanical ventilation. The Flight 60 Blower is driven by internal electrical Blower. The Blower can be operated by an external AC or DC voltage, or by internal two rechargeable Backup Li-Ion batteries.

The unit is a class II with BF applied part

Physical Specifications	
Ventilator Weight	6.3 kg
Ventilator Dimensions	11.22 in wide x 11.02 in deep x 9.65 in high 285 mm wide x 280 mm deep x 245 mm high
Reusable Single Patient Circuit	Reusable (single patient) 22 mm ID 6 ft. length adult/pediatric circuit with 1/10 inch (2.5 mm) ID proximal pressure sensing line, 1/10 inch (2.5 mm) ID exhalation valve control drive line, 1/10 inch (2.5 mm) I.D. flow sensing line, exhalation valve, and flow sensing orifice.
Single Use Patient Circuit	Single use 22 mm ID 6 ft. adult/pediatric circuit with 1/10 inch (2.5 mm) ID proximal pressure sensing line, 1/10 inch (2.5 mm) ID exhalation valve control drive line, 1/10 inch (2.5 mm) ID flow sensing line, exhalation valve, and flow sensing orifice.
Connectors	Gas Outlet: ISO 22 mm OD conical Air/Oxygen Inlet: ISO 30 mm female fitting

Electrical Specifications		
Voltage	Frequency	Current Consumption
100 – 240 VAC	50-60 Hz	1.25 Amp MAX
12 – 15 VDC	NA	4.8 Amp MAX

Internal Battery Specifications	
<b>Detachable Battery</b>	
Battery Type	Li-Ion
Nominal Voltage	14.8 VDC
Nominal Pack Capacity	5.2 AH
Charging Time	Three hours MAX
<b>Integral Battery</b>	
Battery Type	Li-Ion
Nominal Voltage	14.8 VDC
Nominal Pack Capacity	2.6 AH
Charging Time	Three hours MAX
Average operating time for both batteries working together: When new and fully charged, the batteries supply power for up to 12 hours of operation at these settings: ACMV mode, f=15, Volume Control=500 mL, Ti=1.0 sec, PEEP=0, Max. Airway pressure = 30 cmH2O/mbar, Power Save mode ON.	

Communication Port	Function
RS-232 Serial Port (COM1)	For updating SW; by certified technician only.
RS-232 Serial Port (COM2)	For online output of the events and error messages to a PC Remote Alarm (Normally Open and Normally Closed options).
Mini RS-485 Serial Port (COM3)	For connecting peripherals - for future use.

USB B type	USB port for downloading the main application from the PC.
USB A type	USB port for uploading LOG files to an external memory stick.
LAN (RJ45)	LAN - for network logging.
<b>Environmental Specifications</b>	
<b>Condition</b>	<b>Range</b>
Operation Temperature	-18 °C to 50 °C / -4 °F to 122 °F
Storage Temperature	-20 °C to 60 °C / -5.8 °F to 160 °F
Operation Pressure (Altitude)	70 KpA to 110 KpA
Humidity	15% to 95% RH at 31 °C
Water Resistance	IP34 (splash proof) IEC 60529
Sinusoidal Vibrations	IEC 60068-2-6
Bump	IEC 68-2-29
Free Fall	IEC 60068-2-32
Random Vibrations Wide Band	IEC 60068-2-6

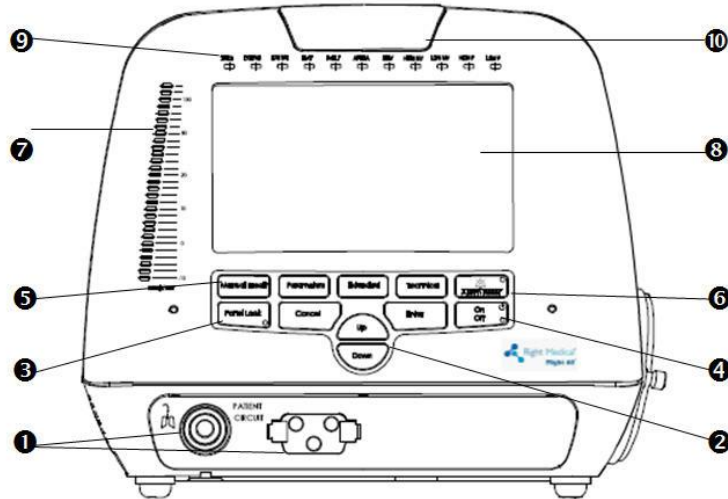

Front Panel

- 1 Patient Circuit Connector
- 2 Up/Down Button
- 3 Panel Lock Button
- 4 On/Off Button
- 5 Manual Breath Button.
- 6 Audio Paused / Alarm Reset Button
- 7 Pressure Gauge
- 8 Display Touch Screen
- 9 LED Indicators
- 10 Primary Alarm LED

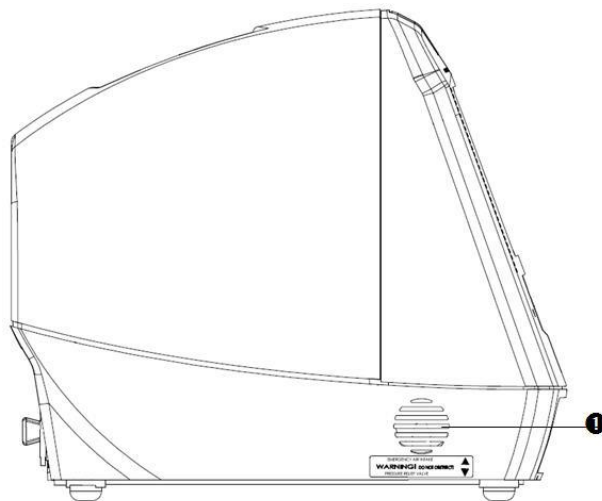

**1 Emergency Air Intake**

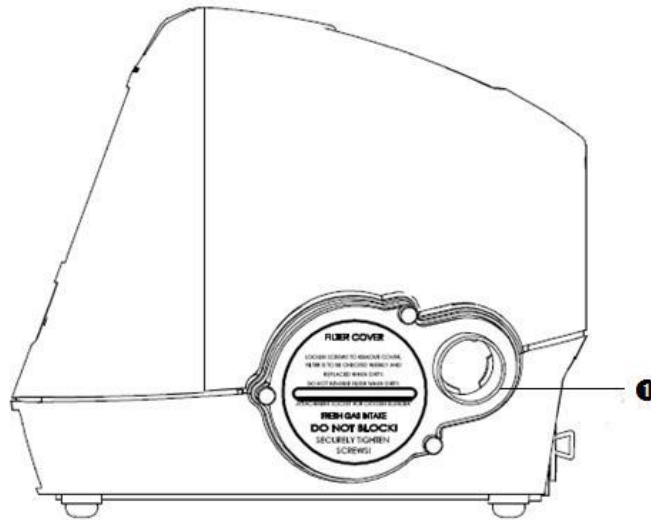

**1 Fresh Gas Intake and Filter Cover**

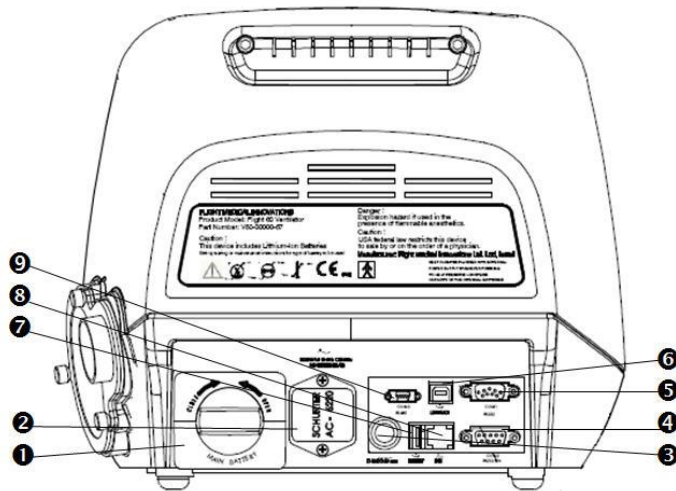

Back Panel

- 1 Detachable Battery**
- 2 AC Connector**  
100 – 240 V AC, 50 - 60 Hz, 1.25A
- 3 DC Connector**  
12 – 15 V DC, 4.8A
- 4 RS-232 Serial Port (COM2)**
- 5 RS-232 Serial Port (COM1)**
- 6 USB B type**

- 7 USB A type
- 8 LAN (RJ45)
- 9 Mini RS-485 (COM3)

The Block Diagram:

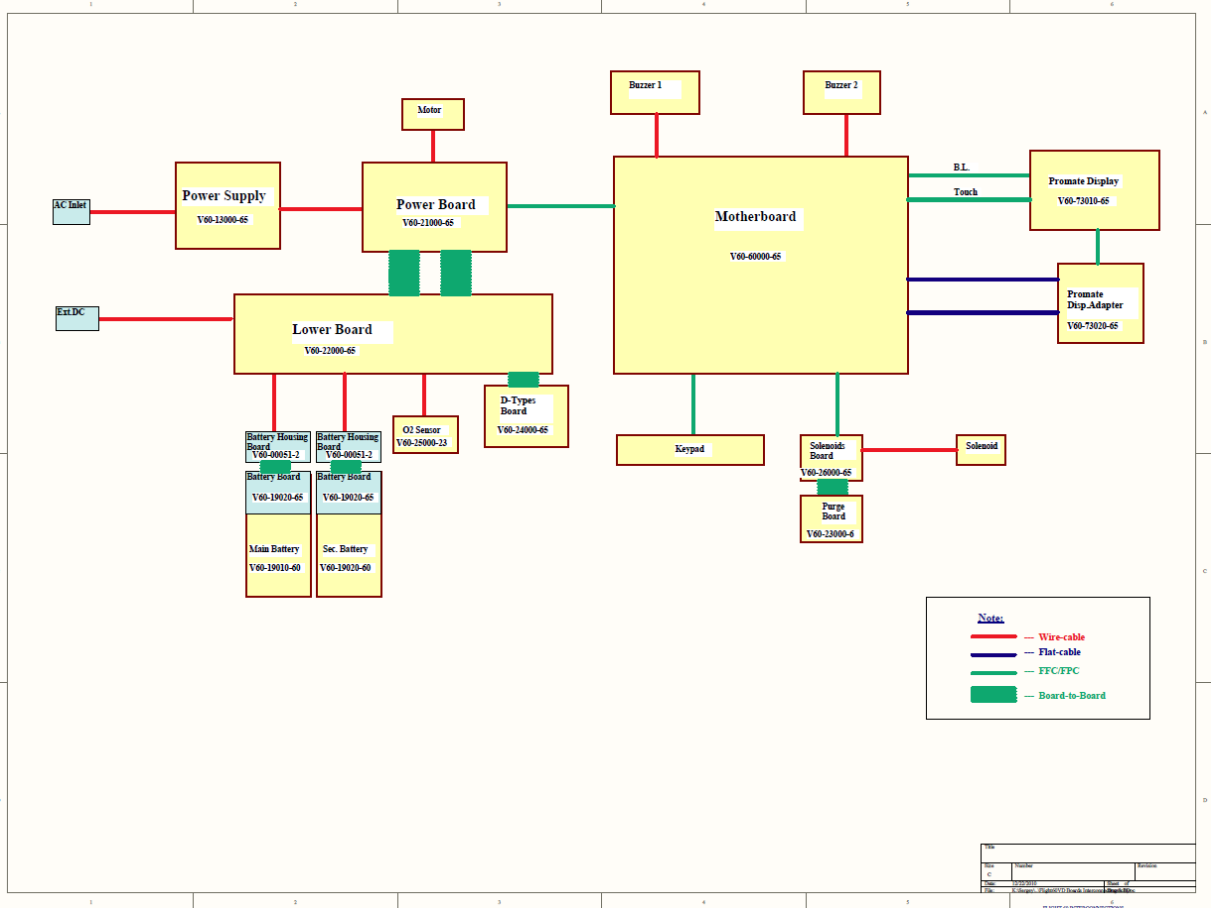

**Report History**

S143040.01 : original report

S143040.02 : update report:

- added US+ Canada national deviation
- update applicant and factory address

IEC 60601-1			
Clause	Requirement + Test	Result - Remark	Verdict

**INSULATION DIAGRAM**

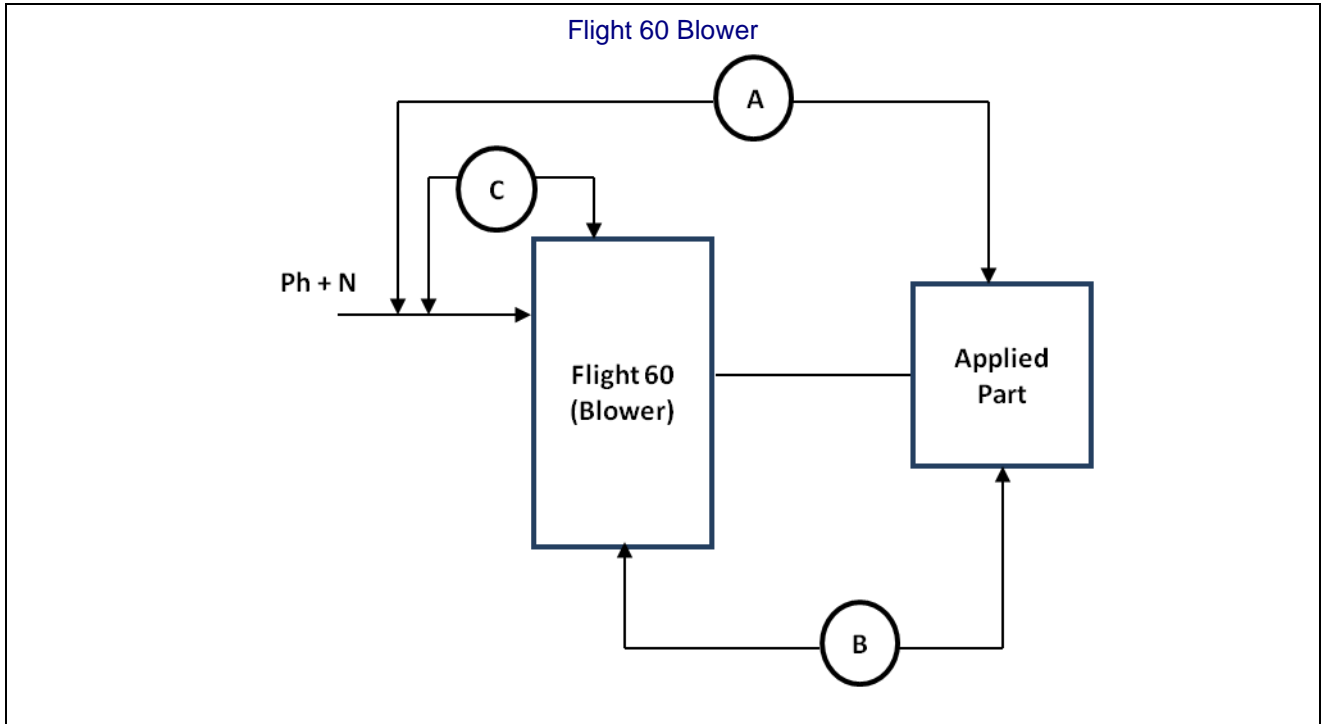

TABLE: To insulation diagram									P
Pollution degree.....: 2									—
Overvoltage category.....: II									—
Altitude.....: 2000m									—
Additional details on parts considered as applied parts.....: <input checked="" type="checkbox"/> None <input type="checkbox"/> Areas _____ (See Clause 4.6 for details)									—
Area	Number and type of Means of Protection: MOOP, MOPP	CTI (IIIb, unless is known)	Working voltage		Required creepage (mm)	Required clearance (mm)	Measured creepage (mm)	Measured clearance (mm)	Remarks
			Vrms [VAC]	Vpk [VAC]					
A	2 MOPP	IIIb	240	340	8	5	-	-	L+N to Applied Part achieved by solid insulation Plastic enclosure 4mm width
B	2 MOOP	IIIb	240	340	6.4	4	7.5	7.5	L/N to Back Metal parts



IEC 60601-1									
Clause	Requirement + Test							Result - Remark	Verdict
C	2 MOPP	IIIb	240	340	8	5	-	-	L+N to enclosure, achieved by solid insulation Plastic enclosure 4mm width

**INSULATION DIAGRAM CONVENTIONS and GUIDANCE:**

A measured value must be provided in the value columns for the device under evaluation. The symbol > (greater than sign) must not be used. Switch-mode power supplies must be re-evaluated in the device under evaluation therefore N/A must not be used with a generic statement that the component is certified.

Insulation diagram is a graphical representation of equipment insulation barriers, protective impedance and protective earthing. If feasible, use the following conventions to generate the diagram:

- All isolation barriers are identified by letters between separate parts of diagram, for example separate transformer windings, optocouplers, wire insulation, creepage and clearance distances.
- Parts connected to earth with large dots are protectively earthed. Other connections to earth are functional
- Applied parts are extended beyond the equipment enclosure and terminated with an arrow.
- Parts accessible to the operator only are extended outside of the enclosure, but are not terminated with an arrow.

IEC 60601-1			
Clause	Requirement + Test	Result - Remark	Verdict
4	<b>GENERAL REQUIREMENTS</b>		Pass
4.1	Requirements of this standard applied in NORMAL USE and reasonably foreseeable misuse		Pass
4.2	A RISK MANAGEMENT PROCESS complying with ISO 14971 was performed .....	See Appended RM Results Table 4.2	Pass
4.3	ESSENTIAL PERFORMANCE functions identified according to MANUFACTURER'S policy for RISK acceptability in RISK MANAGEMENT FILE.....	See Appended Table 4.3 and RM Results Table 4.3	N/A
	ESSENTIAL PERFORMANCE functions maintained following particular tests as applicable		N/A
4.4	EXPECTED SERVICE LIFE stated in RISK MANAGEMENT FILE .....		Pass
4.5	Alternative means of addressing particular RISKS considered acceptable based on MANUFACTURER'S justification that RESIDUAL RISKS resulting from application of alternative means equal to or less than RESIDUAL RISKS resulting from requirements of this standard .....	See Appended RM Results Table 4.5	N/A
4.6	RISK MANAGEMENT PROCESS identifies parts that can come into contact with PATIENT but not defined as APPLIED PARTS, subjected to the requirements for APPLIED PARTS, except for Clause 7.2.10.....	See Appended Insulation Diagram Table and RM Results Table 4.6	Pass
4.7	ME EQUIPMENT remained SINGLE FAULT SAFE, or the RISK remained acceptable as determined by Clause 4.2.....	See Appended RM Results Table 4.7	Pass
	Failure of any one component at a time that could result in a HAZARDOUS SITUATION, including those in 13.1, simulated physically or theoretically .....	See Appended Table 13.2 for simulated physical test, or See Attachment No. __ for theoretical simulation	N/A
	Risk associated with failure of component during EXPECTED SERVICE LIFE of ME EQUIPMENT taken into account to evaluate if a component should be subjected to failure simulation		N/A
4.8	All components and wiring whose failure could result in a HAZARDOUS SITUATION used according to their applicable ratings, except as specified, or by RISK MANAGEMENT PROCESS .....	See Appended RM Results Table 4.8	Pass
	Reliability of components used as MEANS OF PROTECTION assessed for conditions of use in ME EQUIPMENT, and they complied with one of the following:		Pass
	a) Applicable safety requirements of a relevant IEC or ISO standard	See list of critical components 8.10	Pass



IEC 60601-1			
Clause	Requirement + Test	Result - Remark	Verdict
	<b>b) Requirements of this standard applied in the absence of a relevant IEC or ISO standard</b>	See list of critical components 8.10	Pass
<b>4.9</b>	<b>A COMPONENT WITH HIGH-INTEGRITY CHARACTERISTICS provided because a fault in a particular component can generate an unacceptable RISK .....</b>	See appended Table 8.10 & RM Results Table 4.9	N/A
	<b>COMPONENTS WITH HIGH-INTEGRITY CHARACTERISTICS selected and evaluated consistent with their conditions of use and reasonable foreseeable misuse during EXPECTED SERVICE LIFE of ME EQUIPMENT by reviewing RISK MANAGEMENT FILE .....</b>	See Appended RM Results Table 4.9	N/A
<b>4.10</b>	<b>Power supply</b>		Pass
<b>4.10.1</b>	<b>ME EQUIPMENT is suitable for connection to a SUPPLY MAINS, specified to be connected to a separate power supply, can be powered by an INTERNAL ELECTRICAL POWER SOURCE, or a combination of the three .....</b>	Only Supply Mains is the relevant power source	Pass
<b>4.10.2</b>	<b>Maximum rated voltage for ME EQUIPMENT intended to be connected to SUPPLY MAINS is 250 V for HAND-HELD ME EQUIPMENT (V) .....</b>	Not Hand-Held	N/A
	<b>– 250 V d.c. or single-phase a.c., or 500 V polyphase a.c. for ME EQUIPMENT and ME SYSTEMS with a RATED input <math>\leq</math> 4 kVA (V) .....</b>	Maximum rated voltage does not exceed 250 Va.c., single phase	Pass
	<b>– 500 V for all other ME EQUIPMENT and ME SYSTEMS .....</b>	Maximum rated voltage does not exceed 250 Va.c., single phase	N/A
<b>4.11</b>	<b>Power input</b>		Pass
	<b>Steady-state measured input of ME EQUIPMENT or ME SYSTEM at RATED voltage and at operating settings indicated in instructions for use did not exceed marked rating by more than 10% ..</b>	See appended Table 4.11	Pass
	<b>– Measurements on ME EQUIPMENT or a ME SYSTEM marked with one or more RATED voltage ranges made at both upper and lower limits of the range .....</b>	See appended Table 4.11	Pass
	<b>Measurements made at a voltage equal to the mean value of the range when each marking of RATED input was related to the mean value of relevant voltage range .....</b>	See appended Table 4.11	Pass
	<b>Power input, expressed in volt-amperes, measured with a volt-ampere meter or calculated as the product of steady state current (measured as described above) and supply voltage .....</b>	Power input expressed in amperes	N/A

IEC 60601-1			
Clause	Requirement + Test	Result - Remark	Verdict
<b>5</b>	<b>GENERAL REQUIREMENTS FOR TESTING ME EQUIPMENT</b>		Pass
<b>5.1</b>	<b>TYPE TESTS determined in consideration of Clause 4, in particular 4.2</b>		Pass
	<b>Test not performed when analysis indicated condition being tested was adequately evaluated by other tests or methods .....</b>	See Appended RM Results Table 5.1	Pass
	<b>Results of RISK ANALYSIS used to determine combination(s) of simultaneous faults to be tested</b>		Pass
<b>5.2</b>	<b>TYPE TESTS conducted on one representative sample under investigation; multiple samples used simultaneously when validity of results was not significantly affected .....</b>	One sample was tested	Pass
<b>5.3</b>	<b>a) Tests conducted within the environmental conditions specified in technical description</b>	Not specified	N/A
	<b>Temperature (°C), Relative Humidity (%) .....</b>		—
	<b>Atmospheric Pressure (kPa) .....</b>		—
	<b>b) ME EQUIPMENT shielded from other influences that might affect the validity of tests</b>	Complied	Pass
	<b>c) Test conditions modified and results adjusted accordingly when ambient temperature could not be maintained .....</b>	Not required	N/A
<b>5.4</b>	<b>a) ME EQUIPMENT tested under least favourable working conditions specified in instructions for use and identified during RISK ANALYSIS, except as noted .....</b>	See Appended RM Results Table 5.4a	Pass
	<b>b) ME EQUIPMENT with adjustable or controlled operating values by anyone other than SERVICE PERSONNEL adjusted to values least favourable for the relevant test per instructions for use</b>	Not specified	N/A
	<b>c) When test results influenced by inlet pressure and flow or chemical composition of a cooling liquid, tests performed within the limits in technical description .....</b>	No such influence	N/A
	<b>d) Potable water used for cooling</b>	Not required	N/A
<b>5.5</b>	<b>Supply voltage during tests was the least favourable of the voltages specified in 4.10 or voltages marked on ME EQUIPMENT (V) .....</b>	Complied	Pass
	<b>ME EQUIPMENT marked with a RATED frequency range tested at the least favourable frequency within the range (Hz)..... :</b>	As above	Pass



IEC 60601-1			
Clause	Requirement + Test	Result - Remark	Verdict
	<b>ME EQUIPMENT with more than one RATED voltage, or both a.c./ d.c. tested in conditions (see 5.4) related to the least favourable voltage, nature of supply, and type of current..... :</b>	As above	Pass
	<b>ME EQUIPMENT tested with alternative ACCESSORIES and components specified in ACCOMPANYING DOCUMENTS to result in the least favourable conditions..... :</b>	As above	Pass
	<b>ME EQUIPMENT connected to a separate power supply as specified in instructions for use</b>	Not required	N/A
<b>5.6</b>	<b>When failure occurred or probability of future failure detected during sequence of tests, per agreement with manufacturer, all tests affecting results conducted on a new sample</b>	Not required	N/A
	<b>Alternatively, upon repair and modification of the sample, only the relevant tests conducted</b>	Complied	Pass
<b>5.7</b>	<b>ME EQUIPMENT or parts thereof affected by climatic conditions were set up completely, or partially, with covers detached and subjected to a humidity preconditioning prior to tests of Clauses 8.7.4 and 8.8.3..... :</b>	See Appended RM Results Table 5.7	Pass
	<b>Manually detachable parts removed and treated concurrently with major parts and manually removable ACCESS COVERS were opened and detached</b>	Provided	Pass
	<b>ME EQUIPMENT heated to a temperature between T and T + 4 °C for at least 4 h and placed in a humidity chamber with a relative humidity of 93 % ± 3 % and an ambient within 2 °C of T in the range of + 20 °C to + 32 °C for 48 h</b>	Complied	Pass
	<b>When RISK MANAGEMENT PROCESS indicated ME EQUIPMENT can be exposed to high humidity for extended periods (i.e., out-door use), test time extended proportionally (h) .....</b>	As above	Pass
<b>5.8</b>	<b>Unless stated otherwise, tests in this standard sequenced as in Annex B to prevent results of one test on a subsequent test</b>	As above	Pass
<b>5.9</b>	<b>Determination of APPLIED PARTS and ACCESSIBLE PARTS</b>		Pass
<b>5.9.1</b>	<b>APPLIED PARTS identified by inspection and reference to ACCOMPANYING DOCUMENTS .....</b>	Complied	Pass
<b>5.9.2</b>	<b>ACCESSIBLE PARTS</b>		Pass
<b>5.9.2.1</b>	<b>Accessibility, when necessary, determined using standard test finger of Fig 6 applied in a bent or straight position</b>	See Appended Table 5.9.2	Pass

IEC 60601-1			
Clause	Requirement + Test	Result - Remark	Verdict
	Openings preventing entry of test finger of Fig. 6 mechanically tested with a straight un-jointed test finger of the same dimensions with a force of 30 N	No contact with live parts not possible	Pass
	When the straight un-jointed test finger entered, test with the standard test finger (Fig 6) was repeated, if necessary, by pushing the finger through the opening	No contact with live parts not possible	Pass
5.9.2.2	Test hook of Fig. 7 inserted in all openings of ME EQUIPMENT and pulled with a force of 20 N for 10 s	Inserted, no contact with live parts observed	Pass
	All additional parts that became accessible checked using standard test finger and by inspection	Complied	Pass
5.9.2.3	Conductive parts of actuating mechanisms of electrical controls accessible after removal of handles, knobs, levers and the like regarded as ACCESSIBLE PARTS .....	No such parts	N/A
	Conductive parts of actuating mechanisms not considered ACCESSIBLE PARTS when removal of handles, knobs, etc. required use of a TOOL, and inspection of RISK MANAGEMENT FILE indicated the relevant part is unlikely to detach unintentionally during EXPECTED SERVICE LIFE OF ME EQUIPMENT .....	See Appended RM Results Table 5.9.2.3	N/A

6	CLASSIFICATION OF ME EQUIPMENT AND ME SYSTEMS		Pass
6.2	CLASS I ME EQUIPMENT, externally powered	Class II	N/A
	CLASS II ME EQUIPMENT, externally powered		Pass
	INTERNALLY POWERED ME EQUIPMENT	Internally powered	Pass
	EQUIPMENT with means of connection to a SUPPLY MAINS complied with CLASS I or CLASS II ME EQUIPMENT requirements when so connected, and when not connected to SUPPLY MAINS with INTERNALLY POWERED ME EQUIPMENT requirements	Complied	Pass
	TYPE B APPLIED PART	No B applied parts	N/A
	TYPE BF APPLIED PART		Pass
	TYPE CF APPLIED PART	No CF applied parts	N/A
	DEFIBRILLATION-PROOF APPLIED PARTS	No such applied parts	N/A
6.3	ENCLOSURES classified according to degree of protection against ingress of water and particulate matter (IPN <sub>1</sub> N <sub>2</sub> ) as per IEC 60529 .....	IPX0 See RM Results Table 11.6.5.	Pass



IEC 60601-1			
Clause	Requirement + Test	Result - Remark	Verdict
6.4	ME EQUIPMENT or its parts intended to be sterilized classified according to method(s) of sterilization in instructions for use..... :	Method of disinfection specified in User Manual	Pass
6.5	ME EQUIPMENT and ME SYSTEMS intended for use in an OXYGEN RICH ENVIRONMENT classified for such use and complied with 11.2.2	NO OXYGEN RICH ENVIRONMENT use required	N/A
6.6	CONTINUOUS or Non-CONTINUOUS OPERATION ..... :	Continuous operation	Pass

7	<b>ME EQUIPMENT IDENTIFICATION, MARKING, AND DOCUMENTS</b>		Pass
7.1.1	RISK of poor USABILITY associated with the design of ME EQUIPMENT'S identification and marking addressed in a USABILITY ENGINEERING PROCESS..... :		Pass
7.1.2	Legibility of Markings Test for Markings specified in Clause 7.2-7.6..... :	See Appended Table 7.1.2	Pass
7.1.3	Required markings can be removed only with a TOOL or by appreciable force, are durable and remain CLEARLY LEGIBLE during EXPECTED SERVICE LIFE of ME EQUIPMENT in NORMAL USE	Complied	Pass
	a) After tests, adhesive labels didn't loosen up or curl up at edges and markings complied with requirements in Clause 7.1.2..... :	See appended Tables 7.1.3 and 8.10	Pass
	b) Markings required by 7.2-7.6 remained CLEARLY LEGIBLE after marking durability test ... :	See appended Tables 7.1.3 and 8.10	Pass
7.2	<b>Marking on the outside of ME EQUIPMENT or ME EQUIPMENT parts</b>		Pass
7.2.1	At least markings in 7.2.2, 7.2.5, 7.2.6 (not for PERMANENTLY INSTALLED ME EQUIPMENT), 7.2.10, and 7.2.13 were applied when size of EQUIPMENT, its part, an ACCESSORY, or ENCLOSURE did not permit application of all required markings ..... :	See attached copy of Marking Plate	Pass
	Remaining markings fully recorded in ACCOMPANYING DOCUMENTS ..... :	Complied	Pass
	Markings applied to individual packaging when impractical to apply to ME EQUIPMENT	As above	Pass
	A material, component, ACCESSORY, or ME EQUIPMENT intended for a single use, or its packaging marked "Do Not Reuse" or with symbol 28 of Table D.1 (ISO 7000-1051, DB:2004-01)..... :	As above	Pass
7.2.2	MANUFACTURER'S name or trademark marked on ME EQUIPMENT and detachable components..... :	As above	Pass
	Misidentification does not present an unacceptable risk	See Appended RM Results Table 7.2.2	Pass

IEC 60601-1			
Clause	Requirement + Test	Result - Remark	Verdict
	<b>MODEL OR TYPE REFERENCE also marked, except when misidentification would not present an unacceptable RISK.....:</b>	See attached copy of Marking Plate	Pass
	<b>Software forming part of a PEMS identified with a unique identifier, such as revision level or date of release/issue, and identification are available to designated persons .....</b>	Complied	Pass
7.2.3	<b>Symbol 11 on Table D.1 (ISO 7000-1641, DB: 2004-01) used, optionally, advice to OPERATOR to consult ACCOMPANYING DOCUMENTS</b>	Complied	Pass
	<b>Safety sign 10 on Table D.2 (safety sign IEC 60878 Safety 01) used, advising OPERATOR that ACCOMPANYING DOCUMENTS must be consulted</b>	Not specified	N/A
7.2.4	<b>ACCESSORIES marked with name or trademark of MANUFACTURER or supplier, and with a MODEL or TYPE REFERENCE .....</b>	Complied	Pass
	<b>Markings applied to individual packaging when not practical to apply to ACCESSORIES</b>	As above	Pass
7.2.5	<b>MODEL OR TYPE REFERENCE of equipment to be connected to ME EQUIPMENT to provide power, is marked adjacent to the relevant connection point when this connection could result in an unacceptable RISK .....</b>	See Appended RM Results Table 7.2.5	N/A
7.2.6	<b>Connection to the Supply Mains</b>		Pass
	<b>Except for PERMANENTLY INSTALLED ME EQUIPMENT, marking appearing on the outside of part containing SUPPLY MAINS connection and, adjacent to connection point</b>	Complied	Pass
	<b>For PERMANENTLY INSTALLED ME EQUIPMENT, NOMINAL supply voltage or range marked inside or outside of ME EQUIPMENT, preferably, adjacent to supply connection terminals</b>	Not PERMANENTLY ME EQUIPMENT	N/A
	<b>- RATED supply voltage(s) or RATED voltage range(s) with a hyphen (-) between minimum and maximum voltages (V, V-V).....:</b>	Complied	Pass
	<b>Multiple RATED supply voltages or multiple RATED supply voltage ranges are separated by (V/V)....:</b>	As above	Pass
	<b>- Nature of supply (e.g., No. of phases, except single-phase) and type of current .....</b>	As above	Pass
	<b>Symbols 1-5, Table D.1 (symbols of IEC 60417-5032, 5032-1, 5032-2, 5031, and 5033, all DB: 2002-10) used, optionally, for same parameters:</b>	As above	Pass
	<b>- RATED supply frequency or RATED frequency range in hertz.....:</b>	As above	Pass

IEC 60601-1			
Clause	Requirement + Test	Result - Remark	Verdict
	– Symbol 9 of Table D.1 (symbol IEC 60417-5172, DB: 2003-02) used for CLASS II ME EQUIPMENT .....		Pass
7.2.7	RATED input in amps or volt-amps, or in watts when power factor exceeds 0.9 (A, VA, W) .....	RATED input in amps	Pass
	RATED input for one or more RATED voltage ranges provided for upper and lower limits of the range or ranges when the range(s) is/are greater than ± 10 % of the mean value of specified range (A, VA,W) .....	Complied	Pass
	Input at mean value of range marked when range limits do not differ by more than 10 % from mean value (A, VA, W) .....	As above	Pass
	Marking includes long-time and most relevant momentary volt-ampere ratings when provided, each plainly identified and indicated in ACCOMPANYING DOCUMENTS (VA) .....	As above	Pass
	Marked input of ME EQUIPMENT provided with means for connection of supply conductors of other electrical equipment includes RATED and marked output of such means (A, VA, W) .....	As above	Pass
7.2.8	Output connectors		N/A
7.2.8.1	See 16.9.2.1 b) for MULTIPLE SOCKET-OUTLETS integral with ME EQUIPMENT	No MULTIPLE SOCKET-OUTLETS	N/A
7.2.8.2	Output connectors are marked, except for MULTIPLE SOCKET-OUTLETS or connectors intended for specified ACCESSORIES or equipment	As above	N/A
	Rated Voltage (V), Rated Current (A) .....	-	—
	Rated Power (W), Output Frequency (Hz) .....	-	—
7.2.9	ME EQUIPMENT or its parts marked with the IP environmental Code per IEC 60529 according to classification in 6.3 (Table D.3, Code 2) .....	Unit is classified as IPX0	Pass
7.2.10	Degrees of protection against electric shock as classified in 6.2 for all APPLIED PARTS marked with relevant symbols as follows (not applied to parts identified according to 4.6):	Complied	Pass
	TYPE B APPLIED PARTS with symbol 19 of Table D.1 (IEC 60417-5840, DB: 2002-10), not applied in such a way as to give the impression of being inscribed within a square in order to distinguish it from symbol IEC 60417-5333 .....	No type B applied parts	N/A
	TYPE BF APPLIED PARTS with symbol 20 of Table D.1 (IEC 60417-5333, DB: 2002-10) .....	Complied	Pass

IEC 60601-1			
Clause	Requirement + Test	Result - Remark	Verdict
	TYPE OF APPLIED PARTS with symbol 21 of Table D.1 (IEC 60417-5335, DB: 2002-10) .....	No CF applied parts	N/A
	DEFIBRILLATION-PROOF APPLIED PARTS marked with symbols 25-27 of Table D.1 (IEC 60417-5841, IEC 60417-5334, or IEC 60417-5336, all DB: 2002-10):	No defibrillation-proof applied parts	N/A
	Proper symbol marked adjacent to or on connector for APPLIED PART, except marked on APPLIED PART when there is no connector, or connector used for more than one APPLIED PART and different APPLIED PARTS with different classifications .....	Provided	Pass
	Safety sign 2 of Table D.2 (ISO 7010-W001) placed near relevant outlet when protection against effect of discharge of a cardiac defibrillator is partly in the PATIENT cable .....	No defibrillation-proof applied parts	N/A
	An explanation indicating protection of ME EQUIPMENT against effects of discharge of a cardiac defibrillator depends on use of proper cables included in instructions for use .....	No defibrillation-proof applied parts	N/A
7.2.11	ME EQUIPMENT not marked to the contrary assumed to be suitable for CONTINUOUS OPERATION	Intended for continuous operation	Pass
	DUTY CYCLE for ME EQUIPMENT intended for non-CONTINUOUS OPERATION appropriately marked to provide maximum "on" and "off" time .....	Intended for continuous operation	N/A
7.2.12	Type and full rating of a fuse marked adjacent to ACCESSIBLE fuse-holder	Complied	Pass
	Fuse type.....	Time Lag	—
	Voltage (V) and Current (A) rating .....	250V	—
	Operating speed (s) and Breaking capacity.....	8A	—
7.2.13	A safety sign CLEARLY LEGIBLE and visible after INSTALLATION in NORMAL USE applied to a prominent location of EQUIPMENT that produce physiological effects capable of causing HARM to PATIENT or OPERATOR not obvious to OPERATOR ..:	Complied	Pass
	Nature of HAZARD and precautions for avoiding or minimizing the associated RISK described in instructions for use .....	See Appended RM Results Table 7.2.13	Pass
7.2.14	HIGH VOLTAGE TERMINAL DEVICES on the outside of ME EQUIPMENT accessible without the use of a TOOL marked with symbol 24 of Table D.1 (symbol IEC 60417-5036, DB: 2002-10)	No such devices	N/A
7.2.15	Requirements for cooling provisions marked (e.g., supply of water or air).....	Not specified	N/A



IEC 60601-1			
Clause	Requirement + Test	Result - Remark	Verdict
7.2.16	ME EQUIPMENT with limited mechanical stability	As above	N/A
7.2.17	Packaging marked with special handling instructions for transport and/or storage.....:	Information contained in user manual	Pass
	Permissible environmental conditions for transport and storage marked on outside of packaging..... :	As above	N/A
	Packaging marked with a suitable safety sign indicating premature unpacking of ME EQUIPMENT could result in an unacceptable RISK .....	See Appended RM Results Table 7.2.17	N/A
	Packaging of sterile ME EQUIPMENT or ACCESSORIES marked sterile	Not supplied sterile	N/A
7.2.18	RATED maximum supply pressure from an external source marked on ME EQUIPMENT adjacent to each input connector .....	No supply pressure	N/A
7.2.19	Symbol 7 of Table D.1 (IEC 60417-5017, DB:2002-10) marked on FUNCTIONAL EARTH TERMINAL.....:	No functional earth terminal	N/A
7.2.20	Protective means, required to be removed to use a particular function of ME EQUIPMENT with alternate applications, marked to indicate the necessity for replacement when the function is no longer needed .....	No such protective means	N/A
	No marking applied when an interlock provided	No interlock	N/A
7.3	Marking on the inside of ME EQUIPMENT OR ME EQUIPMENT parts		Pass
7.3.1	Maximum power loading of heating elements or lamp-holders designed for use with heating lamps marked near or in the heater (W) .....	No such parts	N/A
	A marking referring to ACCOMPANYING DOCUMENTS provided for heating elements or lamp-holders designed for heating lamps that can be changed only by SERVICE PERSONNEL using a TOOL	Complied	Pass
7.3.2	Symbol 24 of Table D.1 (symbol IEC 60417-5036, DB: 2002-10), or safety sign 3 of Table D.2 used to mark presence of HIGH VOLTAGE parts .....	No High Voltage parts	N/A
7.3.3	Type of battery and mode of insertion when applicable is marked .....	instructions in ACCOMPANYING DOCUMENTS	Pass
	An identifying marking provided referring to instructions in ACCOMPANYING DOCUMENTS for batteries intended to be changed only by SERVICE PERSONNEL using a TOOL .....	As above	Pass

IEC 60601-1			
Clause	Requirement + Test	Result - Remark	Verdict
	A warning provided indicating replacement of lithium batteries or fuel cells when incorrect replacement by inadequately trained personnel would result in an unacceptable RISK (e.g., excessive temperatures, fire or explosion)..... :	As above	Pass
	An identifying marking also provided referring to instructions in ACCOMPANYING DOCUMENTS .....	See Appended RM Results Table 7.3.3	Pass
7.3.4	Fuses, replaceable THERMAL CUT-OUTS and OVER-CURRENT RELEASES, accessible by use of a TOOL, marked by type and full rating at the component or by reference to ACCOMPANYING DOCUMENTS	No such fuses	N/A
	Type .....	-	—
	Voltage (V) and Current (A) rating .....	-	—
	Operating speed (s) and Breaking capacity..... :	-	—
7.3.5	PROTECTIVE EARTH TERMINAL marked with symbol 6 of Table D.1 (IEC 60417-5019, DB: 2002-10), except for the PROTECTIVE EARTH TERMINAL in an APPLIANCE INLET according to IEC 60320-1	Class II equipment	N/A
	Markings on or adjacent to PROTECTIVE EARTH TERMINALS not applied to parts requiring removal to make the connection, and remained visible after connection made	As above	N/A
7.3.6	Symbol 7 of Table D.1 (IEC 60417-5017, DB: 2002 -10) marked on FUNCTIONAL EARTH TERMINALS	No FUNCTIONAL EARTH TERMINALS	N/A
7.3.7	Terminals for supply conductors marked adjacent to terminals, except when no HAZARD would result when interchanging connections	See Appended RM Results Table 7.3.7	Pass
	Terminal markings included in ACCOMPANYING DOCUMENTS when ME EQUIPMENT too small to accommodate markings	Not such case	N/A
	Terminals exclusively for neutral supply conductor in PERMANENTLY INSTALLED ME EQUIPMENT marked with Code 1 of Table D.3 (Code in IEC 60445)	Not permanently equipment	N/A
	Marking for connection to a 3-phase supply, if necessary, complies with IEC 60445	Single phase	N/A
	Markings on or adjacent to electrical connection points not applied to parts requiring removal to make connection, and remained visible after connection made	Complied	Pass
7.3.8	“For supply connections, use wiring materials suitable for at least X °C” (where X > than max temperature measured in terminal box or wiring compartment under NORMAL USE), or equivalent, marked at the point of supply connections	Not required	N/A



IEC 60601-1			
Clause	Requirement + Test	Result - Remark	Verdict
	Statement not applied to parts requiring removal to make the connection, and CLEARLY LEGIBLE after connections made	As above	N/A
7.4	Marking of controls and instruments		Pass
7.4.1	The “on” & “off” positions of switch to control power to ME EQUIPMENT or its parts, including mains switch, marked with symbols 12 and 13 of Table D.1 (IEC 60417-5007, DB: 2002-10, and IEC 60417-5008, DB: 2002-10), or	touch push button	Pass
	– indicated by an adjacent indicator light, or	touch push button indication	Pass
	– indicated by other unambiguous means	No other means	N/A
	The “on/off” positions of push button switch with bi-stable positions marked with symbol 14 of Table D.1 (IEC 60417-5010 DB: 2002-10), and	No such switch	N/A
	– status indicated by adjacent indicator light	As above	N/A
	– status indicated by other unambiguous means	As above	N/A
	The “on/off” positions of push button switch with momentary on position marked with symbol 15 of Table D.1 (symbol 60417-5011 DB: 2002-10), or	Complied	Pass
	– status indicated by adjacent indicator light	As above	Pass
	– status indicated by other unambiguous means	No other means	N/A
7.4.2	Different positions of control devices/switches indicated by figures, letters, or other visual means	Not specified	N/A
	Controls provided with an associated indicating device when change of setting of a control could result in an unacceptable RISK to PATIENT in NORMAL USE, or	See Appended RM Results Table 7.4.2	N/A
	– an indication of direction in which magnitude of the function changes	Not relevant	N/A
7.4.3	Numeric indications of parameters on ME EQUIPMENT expressed in SI units according to ISO 31 except the base quantities listed in Table 1 expressed in the indicated units	Numerical indications not used	N/A
	ISO 1000 applied for application of SI units, their multiples, and certain other units	Numerical indications not used	N/A
	All Markings in Sub-clause 7.4 complied with tests and criteria of 7.1.2 and 7.1.3	See Appended Tables 7.1.2 and 7.1.3.	N/A
7.5	Safety signs		Pass

IEC 60601-1			
Clause	Requirement + Test	Result - Remark	Verdict
	Markings used to convey a warning, prohibition or mandatory action mitigating a RISK not obvious to OPERATOR are safety signs from ISO 7010	See Appended RM Results Table 7.5	Pass
	Affirmative statement together with safety sign placed in instructions for use if insufficient space on ME EQUIPMENT	Complied	Pass
	Specified colours in ISO 3864-1 used for safety signs.....:	As above	Pass
	Safety notices include appropriate precautions or instructions on how to reduce RISK(S)	As above	Pass
	Safety signs including any supplementary text or symbols described in instructions for use	As above	Pass
7.6	Symbols		Pass
7.6.1	Meanings of symbols used for marking described in instructions for use.....:	See Appended Instruction for Use.	Pass
7.6.2	Symbols required by this standard conform to IEC or ISO publication referenced	Complied	Pass
7.6.3	Symbols used for controls and performance conform to the IEC or ISO publication where symbols are defined, as applicable	As above	Pass
7.7	Colours of the insulation of conductors		Pass
7.7.1	PROTECTIVE EARTH CONDUCTOR identified by green and yellow insulation	Class II equipment	N/A
7.7.2	Insulation on conductors inside ME EQUIPMENT forming PROTECTIVE EARTH CONNECTIONS identified by green and yellow at least at terminations	As above	N/A
7.7.3	Green and yellow insulation identify only following conductors:	As above	N/A
	– PROTECTIVE EARTH CONDUCTORS	As above	N/A
	– conductors specified in 7.7.2	As above	N/A
	– POTENTIAL EQUALIZATION CONDUCTORS	No such conductors	N/A
	– FUNCTIONAL EARTH CONDUCTORS	No functional conductors	N/A
7.7.4	Neutral conductors of POWER SUPPLY CORDS are “light blue” specified in IEC 60227-1 or IEC 60245-1	Complied	Pass
7.7.5	Colours of conductors in POWER SUPPLY CORDS in accordance with IEC 60227-1 or IEC 60245-1	As above	Pass
7.8	Indicator lights and controls		Pass
7.8.1	Red indicator lights mean: Warning (i.e., immediate response by OPERATOR required)	provided	Pass

IEC 60601-1			
Clause	Requirement + Test	Result - Remark	Verdict
	<b>Yellow indicator lights mean: Caution (i.e., prompt response by OPERATOR required)</b>	provided	Pass
	<b>Green indicator lights mean: Ready for use</b>	Green is provided to indicate ready for action	Pass
	<b>Other colours, if used: Meaning other than red, yellow, or green (colour, meaning)..... :</b>	No other colours used for warnings	N/A
<b>7.8.2</b>	<b>Red used only for emergency control</b>	No red push buttons	N/A
<b>7.9</b>	<b>ACCOMPANYING DOCUMENTS</b>		Pass
<b>7.9.1</b>	<b>ME EQUIPMENT accompanied by documents containing at least instructions for use, and a technical description</b>	Unit is provided with instructions for use and technical description	Pass
	<b>ACCOMPANYING DOCUMENTS identify ME EQUIPMENT by the following, as applicable:</b>		Pass
	<b>– Name or trade-name of MANUFACTURER and an address the RESPONSIBLE ORGANIZATION can be referred to .....</b> :	Provided	Pass
	<b>– MODEL or TYPE REFERENCE .....</b> :	Provided	Pass
	<b>When ACCOMPANYING DOCUMENTS provided electronically (e.g., on CDROM), RISK MANAGEMENT PROCESS includes instructions as to what is required in hard copy or as markings on ME EQUIPMENT (for emergency operation)</b>	See Appended RM Results Table 7.9.1	Pass
	<b>ACCOMPANYING DOCUMENTS specify special skills, training, and knowledge required of OPERATOR or RESPONSIBLE ORGANIZATION and environmental restrictions on locations of use</b>	Necessary information is provided	Pass
	<b>ACCOMPANYING DOCUMENTS written at a level consistent with education, training, and other needs of individuals for whom they are intended</b>	Comply with these requirements	Pass
<b>7.9.2</b>	<b>Instructions for use include the required information</b>		Pass
<b>7.9.2.1</b>	<b>– intended use of ME EQUIPMENT,</b>	Provided in instructions for use and technical description	Pass
	<b>– frequently used functions, and</b>	As above	Pass
	<b>– known contraindication(s) to use of ME EQUIPMENT</b>	As above	Pass
	<b>Classifications as in Clause 6, all markings per Clause 7.2, and explanation of safety signs and symbols marked on ME EQUIPMENT</b>	As above	Pass
	<b>Instructions for use are in a language acceptable to the intended operator</b>	English	Pass
<b>7.9.2.2</b>	<b>Instructions for use include all warning and safety notices:</b>		N/A



IEC 60601-1			
Clause	Requirement + Test	Result - Remark	Verdict
	<b>Warning statement for CLASS I ME EQUIPMENT indicating: "WARNING: To avoid risk of electric shock, this equipment must only be connected to a supply mains with protective earth"</b>	No such warning	N/A
	<b>Warnings regarding significant RISKS of reciprocal interference posed by ME EQUIPMENT during specific investigations or treatments</b>	As above	N/A
	<b>Information on potential electromagnetic or other interference and advice on how to avoid or minimize such interference</b>	Not relevant	N/A
	<b>Warning statement for ME EQUIPMENT supplied with an integral MULTIPLE SOCKET-OUTLET indicating, "connecting electrical equipment to MSO effectively leads to creating an ME SYSTEM, and can result in a reduced level of safety"</b>	No multiple socket-outlet	N/A
	<b>The RESPONSIBLE ORGANIZATION is referred to this standard for the requirements applicable to ME SYSTEMS</b>	Not specified	N/A
7.9.2.3	<b>Statement on ME EQUIPMENT for connection to a separate power supply indicating "power supply is specified as a part of ME EQUIPMENT or combination is specified as a ME SYSTEM"</b>	As above	N/A
7.9.2.4	<b>Warning statement for mains- operated ME EQUIPMENT with additional power source not automatically maintained in a fully usable condition indicating the necessity for periodic checking or replacement of power source</b>	As above	N/A
	<b>Warning to remove primary batteries when ME EQUIPMENT is not likely to be used for some time when leakage from battery would result in an unacceptable RISK..... :</b>	No primary batteries See Appended RM Results Table 7.9.2.4	N/A
	<b>Specifications of replaceable INTERNAL ELECTRICAL POWER SOURCE when provided .....</b>	Provided in instructions for use and technical description	Pass
	<b>Warning indicating ME EQUIPMENT must be connected to an appropriate power source when loss of power source would result in an unacceptable RISK..... :</b>	See Appended RM Results Table 7.9.2.4	N/A
7.9.2.5	<b>Instructions for use include a description of ME EQUIPMENT, its functions, significant physical and performance characteristics together with the expected positions of OPERATOR, PATIENT, or other persons near ME EQUIPMENT in NORMAL USE</b>	Provided in instructions for use and technical description	Pass
	<b>Information provided on materials and ingredients PATIENT or OPERATOR is exposed to when such exposure can constitute an unacceptable RISK</b>	No such materials or ingredients	N/A

IEC 60601-1			
Clause	Requirement + Test	Result - Remark	Verdict
	Restrictions specified on other equipment or NETWORK/DATA COUPLINGS, other than those forming part of an ME SYSTEM, to which a SIGNAL INPUT/OUTPUT PART may be connected	No other equipment	N/A
	APPLIED PARTS specified	Complied	Pass
7.9.2.6	Information provided indicating where the installation instructions may be found or information on qualified personnel who can perform the installation	Provided in instructions for use and technical description	Pass
7.9.2.7	Instructions provided indicating not to position ME EQUIPMENT to make it difficult to operate the disconnection device when an APPLIANCE COUPLER or separable plug is used as isolation means to meet 8.11.1 a)	No such instructions	N/A
7.9.2.8	Necessary information provided for OPERATOR to bring ME EQUIPMENT into operation including initial control settings, and connection to or positioning of PATIENT prior to use of ME EQUIPMENT, its parts, or ACCESSORIES	Provided in instructions for use and technical description	Pass
7.9.2.9	Information provided to operate ME EQUIPMENT including explanation of controls, displays and signals, sequence of operation, connection of detachable parts or ACCESSORIES, replacement of material consumed during operation	Provided in instructions for use and technical description	Pass
	Meanings of figures, symbols, warning statements, abbreviations and indicator lights described in instructions for use	Provided in instructions for use and technical description	Pass
7.9.2.10	A list of all system messages, error messages, and fault messages provided with an explanation of messages including important causes and possible action(s) to be taken to resolve the problem indicated by the message	Provided in instructions for use and technical description	Pass
7.9.2.11	Information provided for the OPERATOR to safely terminate operation of ME EQUIPMENT	Provided	Pass
7.9.2.12	Information provided on cleaning, disinfection, and sterilization methods, and applicable parameters that can be tolerated by ME EQUIPMENT parts or ACCESSORIES specified	Instructions for Cleaning and Disinfection provided	Pass
	Components, ACCESSORIES or ME EQUIPMENT marked for single use, except when required by MANUFACTURER to be cleaned, disinfected, or sterilized prior to use	As above	Pass
7.9.2.13	Instructions provided on preventive inspection, calibration, maintenance and its frequency	Necessary information is provided in instructions for use and technical description	Pass

IEC 60601-1			
Clause	Requirement + Test	Result - Remark	Verdict
	<b>Information provided for safe performance of routine maintenance necessary to ensure continued safe use of ME EQUIPMENT</b>	Necessary information is provided in instructions for use and technical description	Pass
	<b>Parts requiring preventive inspection and maintenance to be performed by SERVICE PERSONNEL identified including periods of application</b>	As above	Pass
	<b>Instructions provided to ensure adequate maintenance of ME EQUIPMENT containing rechargeable batteries to be maintained by anyone other than SERVICE PERSONNEL</b>	As above	Pass
7.9.2.14	<b>A list of ACCESSORIES, detachable parts, and materials for use with ME EQUIPMENT provided</b>	Necessary information is provided in instructions for use and technical description	Pass
	<b>Other equipment providing power to ME SYSTEM sufficiently described (e.g. part number, RATED VOLTAGE, max or min power, protection class, intermittent or continuous service)</b>	No such equipment	N/A
7.9.2.15	<b>RISKS associated with disposal of waste products, residues, etc., and of ME EQUIPMENT and ACCESSORIES at the end of their EXPECTED SERVICE LIFE are identified, and instructions provided on minimizing these RISKS .....</b>	No such products	N/A
7.9.2.16	<b>Instructions for use include information specified in 7.9.3 or identify where it can be found (e.g. in a service manual)</b>	Instructions for use and technical description are provided	Pass
7.9.3	<b>Technical description</b>		Pass
7.9.3.1	<b>All essential data provided for safe operation, transport, storage, and measures or conditions necessary for installing ME EQUIPMENT, and preparing it for use including the following:</b>	Provided in instructions for use and technical description	Pass
	<b>– information as in clause 7.2</b>	As above	Pass
	<b>– permissible environmental conditions of use including conditions for transport and storage</b>	As above	Pass
	<b>– all characteristics of ME EQUIPMENT including range(s), accuracy, and precision of displayed values or where they can be found</b>	Provided in instructions for use and technical description	Pass
	<b>– special installation requirements such as max. permissible apparent impedance of SUPPLY MAINS</b>	No such requirements	N/A
	<b>– permissible range of values of inlet pressure and flow, and chemical composition of cooling liquid used for cooling</b>	No inlet pressure	N/A

IEC 60601-1			
Clause	Requirement + Test	Result - Remark	Verdict
	– a description of means of isolating ME EQUIPMENT from SUPPLY MAINS, when such means not in ME EQUIPMENT	Not specified	N/A
	– a description of means for checking oil level in partially sealed oil filled ME EQUIPMENT or its parts when applicable	No oil	N/A
	– a warning statement addressing HAZARDS that can result from unauthorized modification of ME EQUIPMENT according to following examples	Not specified	N/A
	“WARNING: No modification of this equipment is allowed”	As above	N/A
	“WARNING: Do not modify this equipment without authorization of the manufacturer”	As above	N/A
	“WARNING: If this equipment is modified, appropriate inspection and testing must be conducted to ensure continued safe use of equipment”	As above	N/A
	Technical description separable from instructions for use contains required information, as follows		N/A
	– information as in clause 7.2	Instructions for use and technical description are provided as one document	N/A
	– all applicable classifications in Clause 6, warning and safety notices, and explanation of safety signs marked on ME EQUIPMENT	Instructions for use and technical description are provided as one document	N/A
	– a brief description of ME EQUIPMENT, how it functions, and its significant physical and performance characteristics	Instructions for use and technical description are provided as one document	N/A
	MANUFACTURER’S optional requirements for minimum qualifications of SERVICE PERSONNEL documented in technical description	Instructions for use and technical description are provided as one document	N/A
7.9.3.2	The technical description contains the following required information		Pass
	–type and full rating of fuses used in SUPPLY MAINS external to PERMANENTLY INSTALLED ME EQUIPMENT, when type and rating of fuses are not apparent from information on RATED current and mode of operation of ME EQUIPMENT .....	See Appended RM Results Table 7.9.3.2,	N/A
	– a statement for ME EQUIPMENT with a non-DETACHABLE POWER SUPPLY CORD if POWER SUPPLY CORD is replaceable by SERVICE PERSONNEL, and if so, instructions for correct connection and anchoring to ensure compliance with 8.11.3	Detachable cord used	N/A

IEC 60601-1			
Clause	Requirement + Test	Result - Remark	Verdict
	– instructions for correct replacement of interchangeable or detachable parts specified by MANUFACTURER as replaceable by SERVICE PERSONNEL, and	Provided	Pass
	– warnings identifying nature of HAZARD when replacement of a component could result in an unacceptable RISK, and when replaceable by SERVICE PERSONNEL all information necessary to safely replace the component	Not specified	N/A
7.9.3.3	Technical description indicates, MANUFACTURER will provide circuit diagrams, component part lists, descriptions, calibration instructions to assist to SERVICE PERSONNEL in parts repair	As above	N/A
7.9.3.4	Means used to comply with requirements of 8.11.1 clearly identified in technical description	As above	N/A

<b>8</b>	<b>PROTECTION AGAINST ELECTRICAL HAZARDS FROM ME EQUIPMENT</b>		Pass
<b>8.1</b>	<b>Limits specified in Clause 8.4 not exceeded for ACCESSIBLE PARTS and APPLIED PARTS in NORMAL OR SINGLE FAULT CONDITIONS</b>	Confirmed by testing and evaluation	Pass
	<b>NORMAL CONDITION considered as simultaneous occurrence of situations identified in 8.1a)</b>	Cl. 8.1a) was used	Pass
	<b>SINGLE FAULT CONDITION considered to include the occurrences as specified in Clause 8.1b)... :</b>	See Appended RM Results Tables 8.1b(1), (2), (3)	Pass
	<b>ACCESSIBLE PARTS determined according to 5.9</b>	Inspected	Pass
	<b>LEAKAGE CURRENTS measured according to 8.7</b>	See attached table 8.7	Pass
<b>8.2</b>	<b>Requirements related to power sources</b>		N/A
<b>8.2.1</b>	<b>When ME EQUIPMENT specified for connection to a separate power source other than SUPPLY MAINS, separate power source considered as part of ME EQUIPMENT or combination considered as an ME SYSTEM</b>	No separate power source	N/A
	<b>Tests performed with ME EQUIPMENT connected to separate power supply when one specified</b>	No separate power source	N/A
	<b>When a generic separate power supply specified, specification in ACCOMPANYING DOCUMENTS examined</b>	No separate power source	N/A
<b>8.2.2</b>	<b>No HAZARDOUS SITUATION other than absence of ESSENTIAL PERFORMANCE developed when a connection with wrong polarity made for ME EQUIPMENT from an external d.c. source</b>	See Appended RM Results Tables 8.2.2	Pass
	<b>ME EQUIPMENT connected with correct polarity did not present an unacceptable RISK</b>	As above	Pass

IEC 60601-1			
Clause	Requirement + Test	Result - Remark	Verdict
	Protective devices that can be reset by anyone without a TOOL restore correct operation on reset	As above	Pass
<b>8.3</b>	<b>Classification of APPLIED PARTS</b>		Pass
	a) APPLIED PART specified in ACCOMPANYING DOCUMENTS as suitable for DIRECT CARDIAC APPLICATION is TYPE CF	No such applied parts	N/A
	b) An APPLIED PART provided with a PATIENT CONNECTION intended to deliver electrical energy or an electrophysiological signal to or from PATIENT is TYPE BF or CF APPLIED PART	BF	Pass
	c) An APPLIED PART not covered by a) or b) is a TYPE B, BF, or CF	No such applied parts	N/A
	d) Requirements of a TYPE B APPLIED PART applied to a part in 4.6 to be subjected to requirements for an APPLIED PART (except marking)	As above	N/A
	Requirements for a TYPE BF or CF APPLIED PART applied as in RISK MANAGEMENT PROCESS	See Appended RM Results Table 8.3d	Pass
<b>8.4</b>	<b>Limitation of voltage, current or energy</b>		Pass
<b>8.4.1</b>	<b>PATIENT CONNECTIONS intended to deliver Current</b>		N/A
	Limits in 8.4.2 not applied to currents intended to flow through body of PATIENT to produce a physiological effect during NORMAL USE	No such applied parts	N/A
<b>8.4.2</b>	<b>ACCESSIBLE PARTS including APPLIED PARTS</b>		Pass
	a) Currents from, to, or between PATIENT CONNECTIONS did not exceed limits for PATIENT LEAKAGE CURRENT and PATIENT AUXILIARY CURRENT per Tables 3 and 4 when measured according to Clause 8.7.4..... :	See appended Table 8.7	Pass
	b) LEAKAGE CURRENTS from, to, or between ACCESSIBLE PARTS did not exceed limits for TOUCH CURRENT in Cl. 8.7.3 c) when measured per Clause 8.7.4 (mA) .....	See appended Table 8.7	Pass
	c) Limits specified in b) not applied to parts when probability of a connection to a PATIENT, directly or through body of OPERATOR, is negligible in NORMAL USE, and the OPERATOR is appropriately instructed	See Appended RM Results Table 8.4.2c	N/A
	– accessible contacts of connectors	Not accessible	N/A
	– contacts of fuseholders accessible during replacement of fuse	Not accessible	N/A
	– contacts of lampholders accessible after removal of lamp	As above	N/A

IEC 60601-1			
Clause	Requirement + Test	Result - Remark	Verdict
	– parts inside an ACCESS COVER that can be opened without a TOOL, or where a TOOL is needed but the instructions for use instruct an OPERATOR other than SERVICE PERSONNEL to open the relevant ACCESS COVER	No such parts	N/A
	Voltage to earth or to other ACCESSIBLE PARTS did not exceed 42.4 V peak a.c. or 60 V d.c. for above parts in NORMAL or single fault condition (V a.c. or d.c.) .....	See appended Table 8.4.2	N/A
	Limit of 60 V d.c applied with no more than 10% peak-to-peak ripple, and when ripple larger than specified value, 42.4 V peak limit applied (V d.c.) .....	See appended Table 8.4.2	N/A
	Energy did not exceed 240 VA for longer than 60 s or stored energy available did not exceed 20 J at a potential up to 2 V (VA or J) .....	See appended Table 8.4.2	N/A
	LEAKAGE CURRENT limits referred to in 8.4.2 b) applied when voltages higher than limits in 8.4.2 c) were present (mA) .....	See appended Table 8.4.2	N/A
	d) Voltage and energy limits specified in c) above also applied to the following:		N/A
	– internal parts, other than contacts of plugs, connectors and socket-outlets, touchable by test pin in Fig 8 inserted through an opening in an ENCLOSURE; and	No touchable internal parts	N/A
	– internal parts touchable by a metal test rod with a diameter of 4 mm and a length of 100 mm, inserted through any opening on top of ENCLOSURE or through any opening provided for adjustment of pre-set controls using a TOOL	No touchable internal parts	N/A
	Test pin or the test rod inserted through relevant openings with minimal force of no more than 1 N	No touchable internal parts	N/A
	Test rod inserted in every possible position through openings provided for adjustment of pre-set controls that can be adjusted in NORMAL USE, with a force of 10 N	No touchable internal parts	N/A
	Test repeated with a TOOL specified in instructions for use	No such tool specified	N/A
	Test rod freely and vertically suspended through openings on top of ENCLOSURE	No touchable internal parts	N/A

IEC 60601-1			
Clause	Requirement + Test	Result - Remark	Verdict
	e) Devices used to de-energize parts when an ACCESS COVER opened without a TOOL gives access to parts at voltages above levels permitted by this Clause comply with 8.11.1 for mains isolating switches and remain effective in SINGLE FAULT CONDITION	The ACCESS COVER cannot be opened without the use of a TOOL	N/A
	A TOOL is required when it is possible to prevent the devices from operating	No need in such TOOL	N/A
8.4.3	Worst case voltage between pins of plug and between either supply pin and ENCLOSURE did not exceed 60 V one s after disconnecting the plug of ME EQUIPMENT or its parts (V) ..... :	See appended Table 8.4.3	Pass
	A triggering circuit used to ensure disconnection occurred at peak of supply voltage waveform	The test was performed 10 times to ensure the result	N/A
	When voltage exceeded 60 V, calculated or measured stored charge didn't exceed 45 µC .. :	See appended Table 8.4.3	N/A
8.4.4	Residual voltage of conductive parts of capacitive circuits, having become accessible after ME EQUIPMENT was de-energized after removal of ACCESS COVERS, didn't exceed 60V or calculated stored charge didn't exceed 45µC .. :	See appended Table 8.4.4	N/A
	A device manually discharging capacitors used when automatic discharging was not possible and ACCESS COVERS could be removed only with aid of a TOOL	No internal capacitive circuits	N/A
	Capacitor(s) and connected circuitry marked with symbol 24 of Table D.1 (IEC 60417-5036, DB: 2002-10), and manual discharging device specified in technical description..... :	No internal capacitive circuits	N/A
8.5	Separation of parts		Pass
8.5.1	MEANS OF PROTECTION (MOP)		Pass
8.5.1.1	Two MEANS of PROTECTION provided for ME EQUIPMENT to prevent APPLIED and other ACCESSIBLE PARTS from exceeding limits in 8.4	Provided	Pass
	Each MEANS OF PROTECTION categorized as a MEANS OF PATIENT PROTECTION or a MEANS OF OPERATOR PROTECTION, taking into account Clause 4.6, and flow chart in Fig A.12	Provided	Pass
	Varnishing, enameling, oxidation, and similar protective finishes and coatings with sealing compounds replasticizing at temperatures expected during operation and sterilization disregarded as MEANS OF PROTECTION	Considered	Pass

IEC 60601-1			
Clause	Requirement + Test	Result - Remark	Verdict
	Coatings and other insulation intended as a MEANS OF PROTECTION complying with IEC 60950-1:2001 considered acceptable as a MEANS OF OPERATOR PROTECTION but not automatically as a MEANS OF PATIENT PROTECTION	Considered	Pass
	RISK MANAGEMENT PROCESS taken into consideration for MEANS OF PATIENT PROTECTION	As above	Pass
	Components and wiring forming a MEANS OF PROTECTION comply with 8.10	Complied	Pass
	Insulation, CREEPAGE, CLEARANCES, components or earth connections not complying with 8.5.1.2 and 8.5.1.3 not considered as MEANS OF PROTECTION, and failure of these parts regarded as NORMAL CONDITION	No such parts	N/A
<b>8.5.1.2</b>	<b>MEANS OF PATIENT PROTECTION (MOPP)</b>		Pass
	Solid insulation forming a MEANS OF PATIENT PROTECTION complied with dielectric strength test of Clause 8.8 at test voltage of Table 6	Complied	Pass
	CREEPAGE and CLEARANCES forming a MEANS OF PATIENT PROTECTION complied with Table 12	Complied	Pass
	PROTECTIVE EARTH CONNECTIONS forming a MEANS OF PATIENT PROTECTION complied with Cl. 8.6	Complied	Pass
	A Y1 capacitor complying with IEC 60384-14 and having passed dielectric strength test for two MEANS OF PATIENT PROTECTION considered equivalent to one MEANS OF PATIENT PROTECTION	See Appended Tables 8.8.3 and 8.10	N/A
	Two capacitors used in series, each RATED for total WORKING VOLTAGE across the pair and have the same NOMINAL capacitance		N/A
	Voltage <sub>Total Working</sub> (V) and C <sub>Nominal</sub> (µF) .....		—
<b>8.5.1.3</b>	<b>MEANS OF OPERATOR PROTECTION (MOOP)</b>		Pass
	Solid insulation forming a MEANS OF OPERATOR PROTECTION complied with:		Pass
	– dielectric strength test of 8.8 at test voltage of Table 6; or		Pass
	– requirements of IEC 60950-1 for INSULATION CO-ORDINATION	IEC60950-1 requirements not used	N/A
	CREEPAGE and CLEARANCES forming a MEANS OF OPERATOR PROTECTION complied with:		Pass
	– limits of Tables 13 to 16 (inclusive); or	Complied	Pass
	– requirements of IEC 60950-1 for INSULATION CO-ORDINATION	IEC60950-1 requirements not used	N/A

IEC 60601-1			
Clause	Requirement + Test	Result - Remark	Verdict
	<b>PROTECTIVE EARTH CONNECTIONS forming a MEANS OF OPERATOR PROTECTION complied with Cl. 8.6, or</b>	Class II equipment	N/A
	<b>– requirements and tests of IEC 60950-1 for protective earthing .....</b> :	IEC60950-1 requirements not used	N/A
	<b>A Y2 capacitor complying with IEC 60384-14 and passing dielectric strength test for one MEANS OF OPERATOR PROTECTION considered equivalent to one MEANS OF OPERATOR PROTECTION .....</b> :	See Appended Tables 8.8.3 and 8.10	N/A
	<b>A Y1 capacitor complying with IEC 60384-14 and having passed dielectric strength test for two MEANS OF OPERATOR PROTECTION considered equivalent to two MEANS OF OPERATOR PROTECTION .....</b> :	See Appended Tables 8.8.3 and 8.10	N/A
	<b>Two capacitors used in series each RATED for total WORKING VOLTAGE across the pair and have the same NOMINAL capacitance</b>		N/A
	<b>Voltage<sub>Total Working</sub> (V) and C<sub>Nominal</sub> (μF) .....</b> :		—
	<b>Points at which impedances of components, CREEPAGE, CLEARANCES, PROTECTIVE EARTH CONNECTIONS or insulation, prevent ACCESSIBLE PARTS from exceeding limits in 8.4 examined whether a failure at any of these points is to be regarded as a NORMAL or SINGLE FAULT CONDITION</b>	No such points	N/A
	<b>A MEANS OF PROTECTION protecting APPLIED PARTS, or parts identified by 4.6 as parts subject to the same requirements, considered MEANS OF PATIENT PROTECTION.....</b> :	Complied	Pass
	<b>A MEANS OF PROTECTION protecting other parts considered MEANS OF OPERATOR PROTECTION ....</b> :	Considered	Pass
<b>8.5.2</b>	<b>Separation of PATIENT CONNECTIONS</b>		N/A
<b>8.5.2.1</b>	<b>PATIENT CONNECTIONS of F-TYPE APPLIED PART separated from all other parts by equivalent to one MEANS OF PATIENT PROTECTION for a WORKING VOLTAGE equal to maximum MAINS VOLTAGE and complied with limit for PATIENT LEAKAGE CURRENT at 110 % of max. MAINS VOLTAGE .....</b> :	See appended Table 8.7.	Pass
	<b>Separation requirement not applied between multiple functions of a single F-TYPE APPLIED PART</b>	Applied for each type of Applied parts	Pass
	<b>PATIENT CONNECTIONS treated as one APPLIED PART in the absence of electrical separation between PATIENT CONNECTIONS of same or another function</b>	Each type of Applied Part considered as single with its own function	Pass

IEC 60601-1			
Clause	Requirement + Test	Result - Remark	Verdict
	<b>MANUFACTURER has defined if multiple functions are to be considered as all within one APPLIED PART or as multiple APPLIED PARTS .....</b> :	As above	N/A
	<b>Classification as TYPE BF, CF, or DEFIBRILLATION-PROOF applied to one entire APPLIED PART</b>	Complied	Pass
	<b>LEAKAGE CURRENT tests conducted per 8.7.4 ....</b> :	See appended Table 8.7	Pass
	<b>Dielectric strength test conducted per 8.8.3....</b> :	See appended Table 8.8.3	Pass
	<b>CREEPAGE and CLEARANCES measured per 8.9 and Tables 11 to 16 as applicable</b>	See Insulation Diagram and Insulation Table	Pass
	<b>A protective device connected between PATIENT CONNECTIONS of an F-TYPE APPLIED PART and ENCLOSURE to protect against excessive voltages did not operate below 500 V r.m.s</b>	No such device	Pass
<b>8.5.2.2</b>	<b>PATIENT CONNECTIONS of a TYPE B APPLIED PART not PROTECTIVELY EARTHED are separated by one MEANS OF PATIENT PROTECTION from metal ACCESSIBLE PARTS not PROTECTIVELY EARTHED ....</b> :	See Appended RM Results Table 8.5.2.2	N/A
	<b>– except when metal ACCESSIBLE PART is physically close to APPLIED PART and can be regarded as a part of APPLIED PART; and</b>	No such Applied parts	N/A
	<b>– RISK that metal ACCESSIBLE PART will make contact with a source of voltage or LEAKAGE CURRENT above permitted limits is acceptably low</b>	As above	N/A
	<b>LEAKAGE CURRENT tests conducted per 8.7.4 ....</b> :	See appended Table 8.7	N/A
	<b>Dielectric strength test conducted per 8.8.3....</b> :	See appended Table 8.8.3	N/A
	<b>Relevant CREEPAGE and CLEARANCES measured per 8.9 and Tables 11 to 16 as applicable</b>	As above	N/A
	<b>The RISK MANAGEMENT FILE reviewed</b>	As above	N/A
<b>8.5.2.3</b>	<b>A connector on a PATIENT lead located at the end of the lead remote from PATIENT, with conductive part not separated from all PATIENT CONNECTIONS by one MEANS OF PATIENT PROTECTION for a WORKING VOLTAGE equal to MAXIMUM MAINS VOLTAGE</b>		N/A
	<b>- cannot be connected to earth or hazardous voltage while the PATIENT CONNECTIONS are in contact with PATIENT .....</b> :	See Appended RM Results Table 8.5.2.3	N/A
	<b>– conductive part of connector not separated from all PATIENT CONNECTIONS did not come into contact with a flat conductive plate of not less than 100 mm diameter</b>	2 MOPP provided	N/A
	<b>– CLEARANCE between connector pins and a flat surface is at least 0.5 mm</b>	As above	N/A

IEC 60601-1			
Clause	Requirement + Test	Result - Remark	Verdict
	– conductive part pluggable into a mains socket protected from making contact with parts at MAINS VOLTAGE by insulation with a CREEPAGE DISTANCE of at least 1.0 mm, a 1500 V dielectric strength and complying with 8.8.4.1	As above	N/A
	– required test finger did not make electrical contact with conductive part when applied against access openings with a force of 10 N, except when RISK MANAGEMENT PROCESS indicated no unacceptable RISK existed from contact with objects other than a mains socket or a flat surface .....	See Appended RM Results Table 8.5.2.3	N/A
<b>8.5.3</b>	<b>MAXIMUM MAINS VOLTAGE</b>		Pass
	– MAXIMUM MAINS VOLTAGE determined to be the highest RATED supply voltage for single-phase or d.c. SUPPLY MAINS powered ME EQUIPMENT, as well as INTERNALLY POWERED ME EQUIPMENT with a means of connection to a SUPPLY MAINS (V)..... :	The MAXIMUM MAINS VOLTAGE is the highest RATED supply voltage 240VAC	Pass
	When less than 100 V, MAXIMUM MAINS VOLTAGE was 250 V	As above	Pass
	– MAXIMUM MAINS VOLTAGE was the highest RATED phase to neutral supply voltage for poly-phase ME EQUIPMENT (V) .....	No poly-phase equipment	N/A
	– for other INTERNALLY POWERED ME EQUIPMENT, maximum mains voltage was 250 V	No internally powered equipment	N/A
<b>8.5.4</b>	<b>WORKING VOLTAGE</b>		Pass
	– Input supply voltage to ME EQUIPMENT was RATED voltage or voltage within RATED range resulting in highest measured value (V) .....	Complied	Pass
	– WORKING VOLTAGE for d.c. voltages with superimposed ripple was average value when peak-to-peak ripple less than 10% of average value or peak voltage when peak-to-peak ripple exceeding 10% of average value (V)..... :	No d.c. voltages with superimposed ripple	N/A
	– WORKING VOLTAGE for each MEANS OF PROTECTION forming DOUBLE INSULATION was voltage DOUBLE INSULATION, as a whole, subjected to (V)..... :	Complied	Pass
	– Intentional or accidental earthing of PATIENT regarded as a NORMAL CONDITION for WORKING VOLTAGE involving a PATIENT CONNECTION not connected to earth	No such risk	N/A

IEC 60601-1			
Clause	Requirement + Test	Result - Remark	Verdict
	– <b>WORKING VOLTAGE</b> between PATIENT CONNECTIONS of an F-TYPE APPLIED PART and ENCLOSURE was highest voltage appearing across insulation in NORMAL USE including earthing of any part of APPLIED PART (V)..... :	No Applied parts	N/A
	– <b>WORKING VOLTAGE</b> for DEFIBRILLATION-PROOF APPLIED PARTS determined disregarding possible presence of defibrillation voltages	As above	N/A
	– <b>WORKING VOLTAGE</b> was equal to resonance voltage in case of motors provided with capacitors between the point where a winding and a capacitor are connected together and a terminal for external conductors (V)..... :	No motor capacitors	N/A
8.5.5	DEFIBRILLATION-PROOF APPLIED PARTS	No such Applied parts	N/A
8.5.5.1	Classification “DEFIBRILLATION-PROOF APPLIED PART” applied to one APPLIED PART in its entirety, but not separate functions of same APPLIED PART	No such Applied parts	N/A
	Possibility of an OPERATOR receiving a shock from such parts taken into consideration in RISK MANAGEMENT PROCESS	No such Applied parts	N/A
	Isolation of PATIENT CONNECTIONS of a DEFIBRILLATION-PROOF APPLIED PART from other parts of ME EQUIPMENT accomplished as follows:	No such Applied parts	N/A
	a) No hazardous electrical energies appear during a discharge of cardiac defibrillator .....	See Appended Table 8.5.5.1a	N/A
	b) ME EQUIPMENT complied with relevant requirements of this standard, providing BASIC SAFETY and ESSENTIAL PERFORMANCE following exposure to defibrillation voltage, and recovery time stated in ACCOMPANYING DOCUMENTS..... :	See Appended Table 8.5.5.1b	N/A
8.5.5.2	Means provided to limit energy delivered to a 100 Ω load to at least 90% of energy delivered to this load with ME EQUIPMENT disconnected .. :	See Appended Table 8.5.5.2	N/A
8.6	Protective and functional earthing and potential equalization of ME EQUIPMENT		N/A
8.6.1	Requirements of 8.6.2 to 8.6.8 applied	Class II equipment	N/A
	Parts complying with IEC 60950-1 for protective earthing and serving as MEANS OF OPERATOR PROTECTION but not PATIENT PROTECTION exempted from requirements of 8.6.2 to 8.6.8	No compliance to the requirements and tests of IEC 60950-1 performed	N/A
8.6.2	PROTECTIVE EARTH TERMINAL is suitable for connection to an external protective earthing system by a PROTECTIVE EARTH CONDUCTOR in a POWER SUPPLY CORD and a suitable plug or by a FIXED PROTECTIVE EARTH CONDUCTOR..... :	Class II equipment	N/A

IEC 60601-1			
Clause	Requirement + Test	Result - Remark	Verdict
	<b>Clamping means of PROTECTIVE EARTH TERMINAL of ME EQUIPMENT for FIXED supply conductors or POWER SUPPLY CORDS comply with 8.11.4.3, and cannot be loosened without TOOL</b>	As above	N/A
	<b>Screws for internal PROTECTIVE EARTH CONNECTIONS completely covered or protected against accidental loosening from outside..... :</b>	As above	N/A
	<b>Earth pin of APPLIANCE INLET forming supply connection to ME EQUIPMENT regarded as PROTECTIVE EARTH TERMINAL</b>	As above	N/A
	<b>PROTECTIVE EARTH TERMINAL not used for mechanical connection between different parts of ME EQUIPMENT or securing components not related to protective or functional earthing</b>	As above	N/A
<b>8.6.3</b>	<b>PROTECTIVE EARTH CONNECTION not used for a moving part, except when MANUFACTURER demonstrated in RISK MANAGEMENT FILE connection will remain reliable during EXPECTED SERVICE LIFE .....</b> :	See Appended RM Results Table 8.6.3	N/A
<b>8.6.4</b>	<b>a) PROTECTIVE EARTH CONNECTIONS carried fault currents reliably and without excessive voltage drop</b>	See appended Table 8.6.4	N/A
	<b>b) Allowable TOUCH CURRENT and PATIENT LEAKAGE CURRENT in SINGLE FAULT CONDITION were not exceeded, when impedance of PROTECTIVE EARTH CONNECTIONS exceeded values in 8.6.4 a) and Table 8.6.4, due to limited current capability of relevant circuits .....</b> :	See appended Table 8.6.4 & Clause 8.7	N/A
<b>8.6.5</b>	<b>Surface coatings</b>		N/A
	<b>Poorly conducting surface coatings on conductive elements removed at the point of contact</b>	Surface coatings were removed	N/A
	<b>Coating not removed when requirements for impedance and current-carrying capacity met</b>	No such requirements	N/A
<b>8.6.6</b>	<b>Plugs and sockets</b>		Pass
	<b>PROTECTIVE EARTH CONNECTION where connection between SUPPLY MAINS and ME EQUIPMENT or between separate parts of ME EQUIPMENT made via a plug and socket was made before and interrupted after supply connections</b>	Class II equipment	N/A
	<b>- applied also where interchangeable parts are PROTECTIVELY EARTHED</b>	No such parts	N/A
<b>8.6.7</b>	<b>Terminal for connection of a POTENTIAL EQUALIZATION CONDUCTOR</b>		N/A

IEC 60601-1			
Clause	Requirement + Test	Result - Remark	Verdict
	– Terminal is accessible to OPERATOR with ME EQUIPMENT in any position of NORMAL USE	No potential equalization conductor	N/A
	– RISK of accidental disconnection minimized in NORMAL USE	No potential equalization conductor	N/A
	– Terminal allows conductor to be detached without a TOOL	No potential equalization conductor	N/A
	– Terminal not used for a PROTECTIVE EARTH CONNECTION	No potential equalization conductor	N/A
	– Terminal marked with symbol 8 of Table D.1 (i.e., symbol IEC 60417-5021)	No potential equalization conductor	N/A
	– Instructions for use contain information on function and use of POTENTIAL EQUALIZATION CONDUCTOR together with a reference to requirements of this standard	No potential equalization conductor	N/A
	POWER SUPPLY CORD does not incorporate a POTENTIAL EQUALIZATION CONDUCTOR	No potential equalization conductor	N/A
8.6.8	FUNCTIONAL EARTH TERMINAL not used to provide a PROTECTIVE EARTH CONNECTION	No FUNCTIONAL EARTH TERMINAL	N/A
8.6.9	Class II ME EQUIPMENT		Pass
	Third conductor of POWER SUPPLY CORD connected to protective earth contact of MAINS PLUG provided with CLASS II ME EQUIPMENT with isolated internal screens used as functional earth connection to the screen's FUNCTIONAL EARTH TERMINAL, coloured green and yellow	No functional earth, Inlet has only 2 conductors for L/N , no Third conductor	N/A
	Two MEANS OF PROTECTION provided by insulation of internal screens and all internal wiring connected to them with a related explanation in technical description .....	provided	Pass
8.7	LEAKAGE CURRENTS and PATIENT AUXILIARY CURRENTS		Pass
8.7.1	a) Electrical isolation providing protection against electric shock limits currents to values in 8.7.3..... :	See appended Tables 8.7	Pass
	b) Specified values of EARTH LEAKAGE, TOUCH, PATIENT LEAKAGE, and PATIENT AUXILIARY CURRENTS applied in combination of conditions in appended Table 8.7 .....	See appended Tables 8.7	Pass
8.7.2	Allowable values specified in 8.7.3 applied under SINGLE FAULT CONDITIONS of 8.1 b), except	Applied	Pass
	– where insulation used in conjunction with a PROTECTIVE EARTH CONNECTION, insulation short circuited only under conditions in 8.6.4 b)	No such case	N/A

IEC 60601-1			
Clause	Requirement + Test	Result - Remark	Verdict
	– the only SINGLE FAULT CONDITION for EARTH LEAKAGE CURRENT was interruption of one supply conductor at a time	Complied	Pass
	– LEAKAGE CURRENTS and PATIENT AUXILIARY CURRENT not measured in SINGLE FAULT CONDITION of short circuiting of one constituent part of DOUBLE INSULATION	As above	Pass
	SINGLE FAULT CONDITIONS not applied at same time as special test conditions of MAXIMUM MAINS VOLTAGE on APPLIED PARTS and non-PROTECTIVELY EARTHED parts of ENCLOSURE	As above	Pass
<b>8.7.3</b>	<b>Allowable Values</b>		Pass
	a) Allowable values in 8.7.3 b), c), and d) measured based on, and are relative to currents in Fig 12 a), or by a device measuring frequency contents of currents as in Fig 12 b. :	See appended Table 8.7	Pass
	b) Allowable values of PATIENT LEAKAGE and AUXILIARY CURRENTS are according to Tables 3 & 4, and values of a.c. are relative to currents having a frequency not less than 0.1Hz ..... :	See appended Table 8.7	N/A
	c) TOUCH CURRENT did not exceed 100 $\mu$ A in NORMAL CONDITION and 500 $\mu$ A in SINGLE FAULT CONDITION ( $I_{TNC}$ , $I_{TSFC}$ )..... :	See appended Table 8.7	Pass
	d) EARTH LEAKAGE CURRENT did not exceed 5 mA in NORMAL CONDITION and 10 mA in SINGLE FAULT CONDITION ( $I_{ENC}$ , $I_{ESFC}$ ) ..... :	See appended Table 8.7	Pass
	Higher values of EARTH LEAKAGE CURRENT permitted for PERMANENTLY INSTALLED ME EQUIPMENT connected to a supply circuit supplying only this ME EQUIPMENT according to local regulations or IEC 60364-7-710 ..... :	See appended Table 8.7	N/A
	e) LEAKAGE CURRENTS, regardless of waveform and frequency, did not exceed 10 mA r.m.s. in NORMAL or in SINGLE FAULT CONDITION (measured with a non-frequency-weighted device ..... :	See appended Table 8.7	N/A
<b>8.7.4</b>	<b>LEAKAGE and PATIENT AUXILIARY CURRENTS measurements ..... :</b>	See appended Table 8.7	N/A
<b>8.8</b>	<b>Insulation</b>		Pass
<b>8.8.1</b>	<b>Insulation relied on as MEANS OF PROTECTION, including REINFORCED INSULATION and insulation between parts of opposite polarity of MAINS PART on SUPPLY MAINS side of mains fuse or OVER-CURRENT RELEASE</b>	Provided	Pass
	<b>Insulation exempted from test (complies with clause 4.8)</b>	Not such case	N/A

IEC 60601-1			
Clause	Requirement + Test	Result - Remark	Verdict
	<b>Insulation forming MEANS OF OPERATOR PROTECTION and complying with IEC 60950-1 for INSULATION CO-ORDINATION not tested as in 8.8</b>	No co-ordination required	N/A
<b>8.8.2</b>	<b>Distance through solid insulation or use of thin sheet material</b>		Pass
	<b>Solid insulation forming SUPPLEMENTARY or REINFORCED INSULATION for a PEAK WORKING VOLTAGE greater than 71 V provided with:</b>	Plastic enclosure 4mm	Pass
	<b>a) 0.4 mm, min, distance through insulation, or</b>	Plastic enclosure 4mm	Pass
	<b>b) does not form part of an ENCLOSURE and not subject to handling or abrasion during NORMAL USE, and comprised of:</b>	No such insulation	N/A
	<b>– at least two layers of material, each passed the appropriate dielectric strength test, or</b>	No such insulation	N/A
	<b>– three layers of material, for which all combinations of two layers together passed the appropriate dielectric strength test</b>	No such insulation	N/A
	<b>Dielectric strength test for one or two layers was same as for one MEANS OF PROTECTION for SUPPLEMENTARY INSULATION</b>	Complied	Pass
	<b>Dielectric strength test for one or two layers was same as for two MEANS OF PROTECTION for REINFORCED INSULATION</b>	Complied	Pass
	<b>BASIC, SUPPLEMENTARY, and REINFORCED INSULATION required between windings of wound components separated by interleaved insulation complying with a) or b), or both, except when</b>	Complied in approved power supply	Pass
	<b>c) Wire with solid insulation, other than solvent based enamel, complying with a)</b>	As above	Pass
	<b>d) Wire with multi-layer extruded or spirally wrapped insulation complying with b) and complying with Annex L</b>	As above	Pass
	<b>e) Finished wire with spirally wrapped or multi-layer extruded insulation, complying with Annex L</b>	As above	Pass
	<b>– BASIC INSULATION: minimum two wrapped layers or one extruded layer</b>	reinforced insulation is provided between live parts and accessible not protectively earthed conductive parts	Pass
	<b>– SUPPLEMENTARY INSULATION: minimum two layers, wrapped or extruded</b>	No such insulation	N/A
	<b>– REINFORCED INSULATION: minimum three layers, wrapped or extruded</b>	Reinforced/double insulation is provided between live parts and accessible non-productively earthed parts	N/A



IEC 60601-1			
Clause	Requirement + Test	Result - Remark	Verdict
	In d) and e), for spirally wrapped insulation with CREEPAGE DISTANCES between layers less than in Table 12 or 16 (Pollution Degree 1) depending on type of insulation, path between layers sealed as a cemented joint in 8.9.3.3 and test voltages of TYPE TESTS in L.3 equal 1.6 times of normal values	No such insulation	N/A
	Protection against mechanical stress provided where two insulated wires or one bare and one insulated wire are in contact inside wound component, crossing at an angle between 45° and 90° and subject to winding tension .....	No such insulation	N/A
	Finished component complied with routine dielectric strength tests of 8.8.3.....	No such insulation	N/A
	Tests of Annex L not repeated since material data sheets confirm compliance .....	No such insulation	N/A
8.8.3	<b>Dielectric Strength</b>		Pass
	Solid insulating materials with a safety function withstood dielectric strength test voltages .....	See appended Table 8.8.3	Pass
8.8.4	<b>Insulation other than wire insulation</b>		Pass
8.8.4.1	<b>Resistance to heat retained by all insulation and insulating partition walls during EXPECTED SERVICE LIFE OF ME EQUIPMENT</b>	No excessive temperatures, see appended table 11.1	Pass
	ME EQUIPMENT and RISK MANAGEMENT FILE examined in conjunction with resistance to moisture, dielectric strength, and mechanical strength tests .....	Complied	Pass
	Satisfactory evidence of compliance provided by manufacturer for resistance to heat .....	No excessive temperatures, see appended table 11.1	N/A
	Tests conducted in absence of satisfactory evidence for resistance to heat .....	No excessive temperatures, see appended table 11.1	N/A
	a) ENCLOSURE and other external parts of insulating material, except insulation of flexible cords and parts of ceramic material, subjected to ball-pressure test using apparatus of Fig 21	No excessive temperature, see appended table 11.1. No deterioration	N/A
	b) Parts of insulating material supporting uninsulated parts of MAINS PART subjected to ball-pressure test in a), except at 125 °C ± 2 ° C or ambient indicated in technical description ±2°C plus temperature rise determined during test of 11.1 of relevant part, if higher (°C) .....	Not required	N/A
	Test not performed on parts of ceramic material, insulating parts of commutators, brush-caps, and similar, and on coil formers not used as REINFORCED INSULATION	No such parts	N/A

IEC 60601-1			
Clause	Requirement + Test	Result - Remark	Verdict
<b>8.8.4.2</b>	<b>Resistance to environmental stress</b>		N/A
	<b>Insulating characteristics and mechanical strength of all MEANS OF PROTECTION not likely to be impaired by environmental stresses including deposition of dirt resulting from wear of parts within EQUIPMENT, potentially reducing CREEPAGE and CLEARANCES below 8.9</b>	No dirt and dust within unit	N/A
	<b>Ceramic and similar materials not tightly sintered, and beads alone not used as SUPPLEMENTARY OF REINFORCED INSULATION</b>	No such materials	N/A
	<b>Insulating material with embedded heating conductors considered as one MEANS OF PROTECTION but not two MEANS OF PROTECTION</b>	No such materials	N/A
	<b>Parts of natural latex rubber aged by suspending samples freely in an oxygen cylinder containing commercial oxygen to a pressure of 2.1 MPa ± 70 kPa, with an effective capacity of at least 10 times volume of samples</b>	No such materials	N/A
	<b>There were no cracks visible to naked eyes after samples kept in cylinder at 70 °C ± 2 °C for 96h, and afterwards, left at room temperature for at least 16h</b>	No such condition	N/A
<b>8.9</b>	<b>CREEPAGE DISTANCES and AIR CLEARANCES</b>		Pass
<b>8.9.1.1</b>	<b>CREEPAGE DISTANCES and AIR CLEARANCES are ≥ to values in Tables 11 to 16 (inclusive), except as specified in Clauses 8.9.1.2 to 8.9.1.15</b>	Provided in approved power entry module	Pass
<b>8.9.1.2</b>	<b>Tables 11 to 16 (inclusive) not applied to CREEPAGE and CLEARANCES forming MEANS OF OPERATOR PROTECTION per IEC 60950-1 for INSULATION CO-ORDINATION and used under conditions compliance was tested</b>	IEC60950-1 requirements not used	N/A
<b>8.9.1.3</b>	<b>Specified min CLEARANCE applied as min CREEPAGE for CREEPAGE DISTANCES across glass, mica, ceramic and other inorganic insulating materials with similar tracking characteristics</b>	No such materials	N/A
<b>8.9.1.4</b>	<b>When min CREEPAGE derived from Tables 11 to 16 (inclusive) was less than min applicable CLEARANCE, value of min CLEARANCE applied as min CREEPAGE DISTANCE</b>	Adopted	Pass
<b>8.9.1.5</b>	<b>ME EQUIPMENT RATED to operate at an altitude of 2000 m</b>	Not suitable for high altitudes	N/A
	<b>ME EQUIPMENT RATED to operate at an altitude specified by MANUFACTURER (m)..... :</b>	Not specified	N/A

IEC 60601-1			
Clause	Requirement + Test	Result - Remark	Verdict
	<b>Operating altitude corresponding to actual air pressure for ME EQUIPMENT intended for pressurized environments (e.g., aircraft) used to determine multiplication factor from Table 8, and AIR CLEARANCE was multiplied by this factor</b>	Multiplication factor is 1	Pass
	<b>CREEPAGE DISTANCES not subjected to multiplication factors, but were at least as large as the resulting value for AIR CLEARANCE</b>	Adopted	Pass
8.9.1.6	<b>When WORKING VOLTAGE was between those in Tables 11 to 16 (inclusive), CREEPAGE and CLEARANCES calculated as follows:</b>	Adopted	Pass
	<b>– CREEPAGE DISTANCES determined by linear interpolation between the nearest two values, and the calculated spacing rounded off to the next higher 0.1 mm increment (mm)..... :</b>	See Insulation Diagram/Table.	Pass
	<b>– CLEARANCES for PEAK WORKING VOLTAGES above 2800 V peak or d.c. determined by linear interpolation between the nearest two values, and the calculated spacing rounded off to the next higher 0.1 mm increment (mm)..... :</b>	No such peak working voltage	N/A
	<b>– for AIR CLEARANCES corresponding to PEAK WORKING VOLTAGE up to 2800 V peak or d.c., the higher of the two values applied</b>	Adopted	Pass
8.9.1.7	<b>Material groups classified in accordance with Table 9 (Material Group)..... :</b>	Material Group IIIb assumed	Pass
	<b>Material group evaluated using 50 drops of solution A based on test data for material according to IEC 60112 .....</b>	Material Group IIIb assumed	N/A
	<b>Material of unknown group considered IIIb</b>	Material Group IIIb assumed	Pass
8.9.1.8	<b>– Pollution degree 1: Micro-environment sealed to exclude dust and moisture</b>	Pollution degree 2 assumed	N/A
	<b>– Pollution degree 2: Micro-environment with non-conductive pollution, except occasional conductivity caused by condensation</b>	Pollution degree 2 assumed	Pass
	<b>– Pollution degree 3: Micro-environment subject to conductive pollution, or dry non-conductive pollution that could become conductive due to expected condensation</b>	Pollution degree 2 assumed	N/A
	<b>– Pollution degree 4: Micro-environment where continuous conductivity occurs due to conductive dust, rain, or other wet conditions</b>	Pollution degree 2 assumed	N/A
	<b>Pollution degree 4 not used for insulation providing a MEANS OF PROTECTION</b>	Pollution degree 2 assumed	N/A

IEC 60601-1			
Clause	Requirement + Test	Result - Remark	Verdict
	Where insulation between MAINS PART and earth might be compromised, measures such as maintenance ensure that micro-environment is mitigated to a lower pollution degree	Not such case	N/A
8.9.1.9	Overvoltage category classification; value of MAINS TRANSIENT VOLTAGE determined from overvoltage category per IEC60664-1 and NOMINAL a.c. MAINS VOLTAGE using Table 10	Overvoltage category II assumed	Pass
	$V_{MT}$ Peak (V) .....	340V	—
	$V_{MN}$ r.m.s (V) .....	240V	—
8.9.1.10	AIR CLEARANCE for MAINS PARTS (operating on RATED MAINS VOLTAGES up to 300 V) were values for r.m.s. or d.c. RATED MAINS VOLTAGE in Table 13 plus additional CLEARANCE in Table 14 for PEAK WORKING VOLTAGE	RATED MAINS VOLTAGE IS 240V	N/A
8.9.1.11	SUPPLY MAINS overvoltage category II applied according to IEC 60664-1	Overvoltage category II assumed	Pass
	For ME EQUIPMENT intended for overvoltage category III, Tables 13 to 15 (inclusive) not used for clearance, instead values in the next MAINS TRANSIENT VOLTAGE column upwards used	Overvoltage category II assumed	N/A
	When PATIENT protection (Table 12) is required for use of ME EQUIPMENT on overvoltage category III SUPPLY MAINS, guidance provided on values required in the rationale for Cl. 8.9 used	Overvoltage category II assumed	N/A
8.9.1.12	A SECONDARY CIRCUIT derived from a SUPPLY MAINS, normally, considered to be overvoltage category I according to IEC 60664-1 when the MAINS PART is overvoltage category II (Table 15)	Overvoltage category I assumed	Pass
	Table 15 applied to earthed SECONDARY CIRCUIT or INTERNALLY POWERED ME EQUIPMENT	SELV not earthed	N/A
	Requirements for primary circuits in Tables 13 and 14 used for an unearthed SECONDARY CIRCUIT derived from a SUPPLY MAINS	Complied	Pass
	Table 15 applied when SECONDARY CIRCUIT was separated from MAINS PART by a functionally earthed or PROTECTIVELY EARTHED metal screen or transients in SECONDARY CIRCUIT were below the levels expected for overvoltage category I	Not such case	N/A
	Table 15 column for circuits not subject to transient overvoltages applied to:	Not such case	N/A
	– d.c. SECONDARY CIRCUITS reliably connected to earth and have capacitive filtering limiting peak-to-peak ripple to 10 % of d.c. voltage, and	Not such case	N/A
	– circuits in INTERNALLY POWERED ME EQUIPMENT	Not internally powered	N/A

IEC 60601-1			
Clause	Requirement + Test	Result - Remark	Verdict
8.9.1.13	For PEAK WORKING VOLTAGES above 1400 V peak or d.c. Table 15 not applied since all the following conditions were met:	Peak working voltage is 340V	N/A
	– CLEARANCE was at least 5 mm	As above	N/A
	– insulation complied with dielectric strength test of 8.8.3 using an a.c. test voltage with an r.m.s. value equal to 1.06 times PEAK WORKING VOLTAGE, or	As above	N/A
	– a d.c. test voltage equal to peak value of a.c. test voltage with an r.m.s. value equal to 1.06 times PEAK WORKING VOLTAGE, and	As above	N/A
	– CLEARANCE path was partly or entirely through air or along the surface of an insulating material of material group I	As above	N/A
	Dielectric strength test conducted only across part(s) of the path that are through air when CLEARANCE path was also partly along surface of a non- group I material	As above	N/A
8.9.1.14	Minimum CREEPAGE DISTANCES for two MEANS OF OPERATOR PROTECTION obtained by doubling values in Table 16 for one MEANS OF OPERATOR PROTECTION	Provided in approved power entry module	Pass
8.9.1.15	CREEPAGE DISTANCES and AIR CLEARANCES for DEFIBRILLATION-PROOF APPLIED PARTS are 4 mm or more to meet 8.5.5.1	No applied parts	N/A
8.9.2	a) Short circuiting of each single one of CREEPAGE DISTANCES and CLEARANCES in turn did not result in a HAZARDOUS SITUATION for insulation in MAINS PART between parts of opposite polarity, therefore, min CREEPAGE and CLEARANCES not applied..... :	See appended Table 8.9.2	N/A
	b) Contribution to CREEPAGE DISTANCES of grooves or air gaps less than 1 mm wide limited to widths	Adopted	Pass
	c) Relative positioning of CLEARANCE providing a MEANS OF PROTECTION is such that the relevant parts are rigid and located by molding, or there is no reduction of a distance below specified value by deformation or movement of parts	Adopted	Pass
	Normal or likely limited movements of relevant parts taken into consideration when calculating minimum AIR CLEARANCE	Adopted	Pass
8.9.3	Spaces filled by insulating compound		N/A

IEC 60601-1			
Clause	Requirement + Test	Result - Remark	Verdict
8.9.3.1	Only solid insulation requirements applied where distances between conductive parts filled with insulating compound were such that CLEARANCES and CREEPAGE DISTANCES don't exist	No insulation compound	N/A
	Thermal cycling, humidity preconditioning, and dielectric strength tests in 8.9.3.2 and 8.9.3.4 or 8.9.3.3 and 8.9.3.4 conducted	No insulation compound	N/A
8.9.3.2	For insulating compound forming solid insulation between conductive parts, a single sample subjected to thermal cycling PROCEDURE of 8.9.3.4 followed by humidity preconditioning per 5.7 (for 48 hours), followed by dielectric strength test (clause 8.8.3), test voltage multiplied by 1.6 .....	No insulation compound	N/A
	Cracks or voids in insulating compound affecting homogeneity of material didn't occur	No insulation compound	N/A
8.9.3.3	Where insulating compound forms a cemented joint with other insulating parts, three samples tested for reliability of joint	No insulation compound	N/A
	A winding of solvent-based enameled wire replaced for the test by a metal foil or by a few turns of bare wire placed close to cemented joint, and three samples tested as follows:	No insulation compound	N/A
	– One sample subjected to thermal cycling PROCEDURE of 8.9.3.4, and immediately after the last period at highest temperature during thermal cycling, it was subjected to dielectric strength test of 8.8.3 except at 1.6 times the test voltage .....	No insulation compound	N/A
	– The other two samples subjected to humidity preconditioning of 5.7, except for 48 hours only followed by a dielectric strength test of 8.8.3 at 1.6 times the test voltage	No insulation compound	N/A
8.9.3.4	One sample containing the cemented joint subjected to a sequence of temperature cycling tests for 10 times .....	No insulation compound	N/A
8.10	Components and wiring		Pass
8.10.1	Components of ME EQUIPMENT likely to result in an unacceptable RISK by their movements mounted securely as indicated in RISK MANAGEMENT FILE .....	All unit components are mounted securely	Pass
8.10.2	Conductors and connectors of ME EQUIPMENT adequately secured or insulated to prevent accidental detachment in a HAZARDOUS SITUATION .....	Conductors and connectors are adequately secured or insulated	Pass



IEC 60601-1			
Clause	Requirement + Test	Result - Remark	Verdict
	<b>Conductors and connectors of ME EQUIPMENT when breaking free at their joint are not capable of touching circuit points resulting in a HAZARDOUS SITUATION as indicated in RISK MANAGEMENT FILE</b>	Provided	Pass
	<b>Breaking free of one means of mechanical restraint considered a SINGLE FAULT CONDITION</b>	Adopted	Pass
	<b>Stranded conductors are not solder-coated when secured by clamping means to prevent HAZARDOUS SITUATIONS due to poor contact</b>	No stranded conductors	N/A
8.10.3	<b>Flexible cords detachable without a TOOL used to interconnect different parts of ME EQUIPMENT provided with means for connection to comply with requirements for metal ACCESSIBLE PARTS of 8.4 when a connection is loosened or broken as shown by measurement or using test finger</b>	Adopted	Pass
8.10.4	<b>Cord-connected HAND-HELD parts and cord-connected foot-operated control devices</b>		N/A
8.10.4.1	<b>Control devices of ME EQUIPMENT and their connection cords contain only conductors and components operating at 42.4 V peak a.c., max, or 60 V d.c. in circuits isolated from MAINS PART by two MEANS OF PROTECTION</b>	No such parts	N/A
	<b>d.c. limit of 60 V applied to d.c. with no more than 10 % peak-to-peak ripple</b>	DC limit not exceeded	N/A
	<b>42.4 V peak limit applied when ripple exceeded 10 % peak-to-peak limit</b>	Not relevant	N/A
8.10.4.2	<b>Connection and anchorage of a flexible cord to a HAND-HELD or foot-operated control device of ME EQUIPMENT at both ends of cable to control device complied with 8.11.3 when breaking free or shorting between conductors could result in a HAZARDOUS SITUATION</b>	As above	N/A
	<b>This requirement applied to other HAND-HELD parts when disturbance or breaking of one or more of connections could result in a HAZARDOUS SITUATION</b>	As above	N/A
8.10.5	<b>Mechanical protection of wiring</b>		Pass
	<b>a) Internal cables and wiring adequately protected against contact with a moving part or from friction at sharp corners and edges where damage to insulation could result in a HAZARDOUS SITUATION .....</b>	See Appended RM Results Table 8.10.5 No sharp corners and edges	Pass

IEC 60601-1			
Clause	Requirement + Test	Result - Remark	Verdict
	<b>b) Wiring, cord forms, or components are not likely to be damaged during assembly or during opening or closing of ACCESS COVERS where such damage could result in a HAZARDOUS SITUATION as shown by manual tests and RISK MANAGEMENT FILE</b>	Complied	Pass
<b>8.10.6</b>	<b>Guiding rollers of insulated conductors prevent bending of movable insulated conductors around a radius of less than five times the outer diameter of the lead concerned in NORMAL USE</b>	As above	Pass
<b>8.10.7</b>	<b>a) Insulating sleeve that can only be removed by breaking or cutting, or secured at both ends, is used on internal wiring of when needed .....</b>	See appended Table 8.10 Insulating sleeve can only be removed by cutting	Pass
	<b>b) Sheath of a flexible cord not used as a MEANS OF PROTECTION inside ME EQUIPMENT when it is subject to mechanical or thermal stresses beyond its RATED characteristics</b>	No such cord	N/A
	<b>c) Insulated conductors subject to temperatures &gt; 70 °C in NORMAL USE provided with insulation of heat-resistant material when compliance is likely to be impaired due to deterioration of insulation .....</b>	See appended Table 8.10 No such conductors subjected to temperatures > 70 °C in normal use	N/A
<b>8.11</b>	<b>MAINS PARTS, components and layout</b>		Pass
<b>8.11.1</b>	<b>a) ME EQUIPMENT provided with means of electrically isolating its circuits from SUPPLY MAINS simultaneously on all poles.....</b>	See appended Table 8.10	Pass
	<b>PERMANENTLY INSTALLED ME EQUIPMENT connected to a poly-phase SUPPLY MAINS equipped with a device not interrupting neutral conductor, provided local installation conditions prevent voltage on neutral conductor from exceeding limits in 8.4.2 c)</b>	No permanently equipment	N/A
	<b>b) Means of isolation incorporated in ME EQUIPMENT, and external means described in technical description .....</b>	See appended Table 8.10	Pass
	<b>c) A SUPPLY MAINS switch used to comply with 8.11.1 a) complies with CREEPAGE and CLEARANCES in IEC 61058-1 for a MAINS TRANSIENT VOLTAGE of 4 kV .....</b>	See appended Table 8.10	Pass
	<b>d) A SUPPLY MAINS switch not incorporated in a POWER SUPPLY CORD or external flexible lead</b>	Not incorporated	N/A
	<b>e) Direction of movement of actuator of a SUPPLY MAINS switch used to comply with 8.11.1 a) complies with IEC 60447</b>	Complied	Pass

IEC 60601-1			
Clause	Requirement + Test	Result - Remark	Verdict
	<b>f) A suitable plug device such as an APPLIANCE COUPLER or a flexible cord with a MAINS PLUG used in non-PERMANENTLY INSTALLED ME EQUIPMENT to isolate it from SUPPLY MAINS considered to comply with 8.11.1 a) .....</b> :	See appended Table 8.10	Pass
	<b>g) A fuse or a semiconductor device not used as an isolating means</b>	A fuse used as isolating means	Pass
	<b>h) ME EQUIPMENT not provided with a device causing disconnection of ME EQUIPMENT from SUPPLY MAINS by producing a short circuit resulting in operation of an overcurrent protection device</b>	No such device	N/A
	<b>i) Parts within ENCLOSURE of ME EQUIPMENT with a circuit &gt; 42.4 V peak a.c. or 60 V d.c. that cannot be disconnected from its supply by an external switch or a plug device accessible at all times is protected against touch even after opening ENCLOSURE by an additional covering</b>	No such parts	N/A
	<b>A clear warning notice is marked on outside of ME EQUIPMENT to indicate it exceeds allowable touch voltage (symbol 10 of Table D.1 is insufficient)</b>	Not required	N/A
	<b>For a part that could not be disconnected from supply by an external switch or a plug device accessible at all times, the required cover or warning notice complied with this clause</b>	No such part	N/A
	<b>Standard test finger of Fig 6 applied</b>	Not required	N/A
<b>8.11.2</b>	<b>MULTIPLE SOCKET-OUTLETS integral with ME EQUIPMENT complied with 16.2 d), second dash; and 16.9.2</b>	No multiple socket-outlets	N/A
<b>8.11.3</b>	<b>POWER SUPPLY CORDS</b>		Pass
<b>8.11.3.1</b>	<b>MAINS PLUG not fitted with more than one POWER SUPPLY CORD</b>	Adopted	Pass
<b>8.11.3.2</b>	<b>POWER SUPPLY CORDS are no less robust than ordinary tough rubber sheathed flexible cord (IEC 60245-1:2003, Annex A, designation 53) or ordinary polyvinyl chloride sheathed flexible cord (IEC 60227-1:1993, Annex A, design. 53).. :</b>	See appended Table 8.10	Pass
	<b>Only polyvinyl chloride insulated POWER SUPPLY CORD with appropriate temperature rating used for ME EQUIPMENT having external metal parts with a temperature &gt; 75 °C touchable by the cord in NORMAL USE .....</b> :	See appended Table 8.10	N/A
<b>8.11.3.3</b>	<b>NOMINAL cross-sectional area of conductors of POWER SUPPLY CORDS of ME EQUIPMENT is not less than in Table 17 (mm<sup>2</sup> Cu)..... :</b>	Provided	Pass



IEC 60601-1			
Clause	Requirement + Test	Result - Remark	Verdict
8.11.3.4	APPLIANCE COUPLERS complying with IEC 60320-1 are considered to comply with 8.11.3.5 and 8.11.3.6 .....	See appended Table 8.10	Pass
8.11.3.5	<b>Cord anchorage (for APPLIANCE COUPLERS not complying with IEC 60320-1)</b>		N/A
	<b>a) Conductors of POWER SUPPLY CORD provided with strain relieve and insulation protected from abrasion at point of entry to ME EQUIPMENT or a MAINS CONNECTOR by a cord anchorage</b>	Not required	N/A
	<b>b) Cord anchorage of POWER SUPPLY CORD is made of and arranged as follows when a total insulation failure of POWER SUPPLY CORD caused conductive non-PROTECTIVELY EARTHED ACCESSIBLE PARTS to exceed limits of 8.4:</b>	As above	N/A
	– insulating material, or	As above	N/A
	– metal, insulated from conductive ACCESSIBLE PARTS non-PROTECTIVELY EARTHED by a MEANS OF PROTECTION, or	As above	N/A
	– metal provided with an insulating lining affixed to cord anchorage, except when it is a flexible bushing forming part of the cord guard in 8.11.3.6, and complying with the requirements for one MEANS OF PROTECTION	As above	N/A
	<b>c) Cord anchorage prevents cord from being clamped by a screw bearing directly on cord insulation</b>	As above	N/A
	<b>d) Screws to be operated when replacing POWER SUPPLY CORD do not serve to secure any components other than parts of cord anchorage</b>	As above	N/A
	<b>e) Conductors of POWER SUPPLY CORD arranged to prevent PROTECTIVE EARTH CONDUCTOR against strain as long as phase conductors are in contact with their terminals when cord anchorage fails</b>	As above	N/A
	<b>f) Cord anchorage prevents POWER SUPPLY CORD from being pushed into ME EQUIPMENT or MAINS CONNECTOR</b>	As above	N/A
	<b>Conductors of POWER SUPPLY CORD supplied by MANUFACTURER disconnected from terminals or from MAINS CONNECTOR and cord subjected 25 times to a pull applied with no jerks, each time for 1 s, on sheath of the value in Table 18 .....</b>	See appended Table 8.11.3.5	N/A
	<b>Cord subjected to a torque in Table 18 for 1 min immediately after pull tests</b>	As above	N/A

IEC 60601-1			
Clause	Requirement + Test	Result - Remark	Verdict
	<b>Cord anchorage did not allow cord sheath to be longitudinally displaced by more than 2 mm or conductor ends to move over a distance of more than 1 mm from their connected position</b>	As above	N/A
	<b>CREEPAGE and CLEARANCES not reduced below limits in 8.9</b>	As above	N/A
	<b>It was not possible to push the cord into ME EQUIPMENT or MAINS CONNECTOR to an extent the cord or internal parts would be damaged</b>	As above	N/A
<b>8.11.3.6</b>	<b>POWER SUPPLY CORDS other than for STATIONARY ME EQUIPMENT protected against excessive bending at inlet opening of equipment or of MAINS CONNECTOR by means of an insulating cord guard or by means of an appropriately shaped opening</b>	Complied	Pass
	<b>Cord guard complied with test of IEC 60335-1:2001, Clause 25.14, or</b>		N/A
	<b>ME EQUIPMENT placed such that axis of cord guard projected at an angle of 45° with cord free from stress, and a mass equal 10 x D<sup>2</sup> gram attached to the free end of cord (g) ..... :</b>	See appended Table 8.11.3.6	N/A
	<b>Cord guard of temperature-sensitive material tested at 23 °C ± 2 °C, and flat cords bent in the plane of least resistance</b>		N/A
	<b>Curvature of the cord radius, immediately after mass attached, was not less than 1.5 x D ..... :</b>	See appended Table 8.11.3.6	N/A
<b>8.11.4</b>	<b>MAINS TERMINAL DEVICES</b>		N/A
<b>8.11.4.1</b>	<b>PERMANENTLY INSTALLED and ME EQUIPMENT with non-DETACHABLE POWER SUPPLY CORD replaceable by SERVICE PERSONNEL provided with MAINS TERMINAL DEVICES ensuring reliable connection</b>	Not permanently installed	N/A
	<b>Terminals alone are not used to keep conductors in position, except when barriers are provided such that CREEPAGE and CLEARANCES cannot be reduced below 8.9 if any conductor breaks away</b>	No such terminals	N/A
	<b>Terminals of components other than terminal blocks complying with requirements of this Clause and marked according to 7.3.7 used as terminals intended for external conductors</b>	As above	N/A
	<b>Screws and nuts clamping external conductors do not serve to secure any other component, except they also clamp internal conductors when unlikely to be displaced when fitting the supply conductors</b>	As above	N/A

IEC 60601-1			
Clause	Requirement + Test	Result - Remark	Verdict
<b>8.11.4.2</b>	<b>Arrangement of MAINS TERMINAL DEVICES</b>		Pass
	<b>a) Terminals provided for connection of external cords or POWER SUPPLY CORDS together with PROTECTIVE EARTH TERMINAL grouped to provide convenient means of connection</b>	No such terminals	N/A
	<b>b) PROTECTIVE EARTH CONDUCTOR connections complied with 8.6</b>	Complied	Pass
	<b>c) Marking of MAINS TERMINAL DEVICES complied with 7.3</b>	Complied	Pass
	<b>d) MAINS TERMINAL DEVICES not accessible without use of a TOOL</b>	No Mains terminal devices	N/A
	<b>e) A MEANS OF PROTECTION are not short circuited when one end of a flexible conductor with NOMINAL cross-sectional area is stripped 8 mm and a single free wire is bent in each possible direction</b>	As above	N/A
<b>8.11.4.3</b>	<b>Internal wiring not subjected to stress and CREEPAGE and CLEARANCES not reduced below 8.9 after fastening and loosening a conductor of largest cross-sectional area 10 times</b>	As above	N/A
<b>8.11.4.4</b>	<b>Terminals with clamping means for a rewirable flexible cord did not require special preparation of conductors and conductors were not damaged and did not slip out when clamping means tightened as verified by test of 8.11.3.4</b>	No such terminals	N/A
<b>8.11.4.5</b>	<b>Adequate space provided inside ME EQUIPMENT designed for FIXED wiring or a re-wirable POWER SUPPLY CORD to allow for connection of conductors, and covers fitted without damage to conductors or their insulation</b>	Provided	Pass
	<b>Correct connection and positioning of conductors before ACCESS COVER was fitted verified by an installation test</b>	No conductors before access cover	N/A
<b>8.11.5</b>	<b>Mains fuses and OVER-CURRENT RELEASES</b>		Pass
	<b>A fuse or OVER-CURRENT RELEASE provided in each supply lead for CLASS I and CLASS II ME EQUIPMENT with a functional earth connection per clause 8.6.9, and in at least one supply lead for other single-phase CLASS II ME EQUIPMENT.... :</b>	See appended Table 8.10 and Appended RM Results Table 8.11.5	Pass
	<b>– neutral conductor not fused for PERMANENTLY INSTALLED ME EQUIPMENT</b>	Not permanently installed equipment	N/A



IEC 60601-1			
Clause	Requirement + Test	Result - Remark	Verdict
	<b>– fuses or OVER-CURRENT RELEASES omitted due to provision of two MEANS OF PROTECTION between all parts of opposite polarity within MAINS PART, and between all parts of MAINS PART and earth, and such provisions continued within all components</b>	Complied	Pass
	<b>Effect of short-circuit fault conditions in other circuits taken into consideration before eliminating fuses or OVER-CURRENT RELEASES</b>	As above	Pass
	<b>Protective devices have adequate breaking capacity to interrupt the maximum fault current including the available short-circuit .....</b> :	See appended Table 8.10	Pass
	<b>A fuse or OVER-CURRENT RELEASE not provided in a PROTECTIVE EARTH CONDUCTOR</b>	Not provided	Pass
	<b>Fuses complying with IEC 60127 have high breaking capacity (1 500 A) and prospective short-circuit current &gt; 35 A or 10 times current rating of the fuse, whichever is greater</b>	Complied	Pass
	<b>Justification for omission of fuses or OVER-CURRENT RELEASES is in RISK MANAGEMENT FILE</b>	See RISK MANAGEMENT FILE	N/A
<b>8.11.6</b>	<b>Internal wiring of the MAINS PART</b>		Pass
	<b>a) Cross-sectional area of internal wiring in a MAINS PART between MAINS TERMINAL DEVICE and protective devices is not less than minimum required for POWER SUPPLY CORD as in clause 8.11.3.3 (mm<sup>2</sup> Cu).....</b> :	Provided	Pass
	<b>b) Cross-sectional area of other wiring in MAINS PART and sizes of tracks on printed wiring circuits sufficient to prevent fire in case of fault currents.....</b> :	See appended Table 8.10	Pass
	<b>When necessary, ME EQUIPMENT connected to a SUPPLY MAINS with max available short-circuit fault, and subsequent simulation of a fault in a single insulation in MAINS PART did not result in any of the HAZARDOUS SITUATIONS in 13.1.2</b>	Evaluated	Pass
<b>9</b>	<b>PROTECTION AGAINST MECHANICAL HAZARDS OF ME EQUIPMENT AND ME SYSTEMS</b>		Pass
<b>9.1</b>	<b>ME EQUIPMENT complies with Clause 4 for design and manufacture, and mechanical strength (15.3)</b>	Provided	Pass
<b>9.2</b>	<b>HAZARDS associated with moving parts</b>		N/A



IEC 60601-1			
Clause	Requirement + Test	Result - Remark	Verdict
9.2.1	When ME EQUIPMENT with moving parts PROPERLY INSTALLED, used per ACCOMPANYING DOCUMENTS or under foreseeable misuse, RISKS associated with moving parts reduced to an acceptable level..... :	See Appended RM Results Table 9.2.1	N/A
	RISK from contact with moving parts reduced to an acceptable level using protective measures, (access, function, shape of parts, energy, speed of motion, and benefits to PATIENT considered)	No moving parts	N/A
	RESIDUAL RISK associated with moving parts considered acceptable when exposure was needed for ME EQUIPMENT to perform its function	As above	N/A
	Warnings marked on ME EQUIPMENT or included in instructions for use when HAZARDS persisted after implementing all reasonable protective measures .....	See provided Marking Labels	N/A
9.2.2	TRAPPING ZONE		N/A
9.2.2.1	ME EQUIPMENT with a TRAPPING ZONE complied with one or more of the following as feasible:	No trapping zone	N/A
	– Gaps in Clause 9.2.2.2, or	No trapping zone	N/A
	– Safe distances in Clause 9.2.2.3, or	No trapping zone	N/A
	– GUARDS and protective measures in 9.2.2.4, or	No trapping zone	N/A
	– Continuous activation in Clause 9.2.2.5	No trapping zone	N/A
	Control of relevant motion complied with 9.2.2.6 when implementation of above protective measures were inconsistent with INTENDED USE of ME EQUIPMENT or ME SYSTEM	No trapping zone	N/A
9.2.2.2	A TRAPPING ZONE considered not to present a MECHANICAL HAZARD when gaps of TRAPPING ZONE complied with dimensions per Table 20 .....	See appended Table 9.2.2.2	N/A
9.2.2.3	A TRAPPING ZONE considered not to present a MECHANICAL HAZARD when distances separating OPERATOR, PATIENT, and others from TRAPPING ZONES exceeded values in ISO 13852 .....	See appended Table 9.2.2.2	N/A
	Distances measured from expected positions of OPERATOR, PATIENT, and others near EQUIPMENT in NORMAL USE or under foreseeable misuse	No trapping zone	N/A
9.2.2.4	GUARDS and protective measures		N/A



IEC 60601-1			
Clause	Requirement + Test	Result - Remark	Verdict
9.2.2.4.1	A TRAPPING ZONE considered not to present a MECHANICAL HAZARD when GUARDS and protective measures were of robust construction, not easy to bypass or render non-operational, and did not introduce additional unacceptable RISK based on results of applicable tests in 15.3 for ENCLOSURES..... :	See Appended Table 15.3	N/A
9.2.2.4.2	FIXED GUARDS held in place by systems that cannot be dismantled without a TOOL	No guards	N/A
9.2.2.4.3	Movable GUARDS that can be opened without a TOOL remained attached when GUARD was open	See Appended RM Results Table 9.2.2.4.3	N/A
	– they are associated with an interlock preventing relevant moving parts from starting to move while TRAPPING ZONE is accessible, and stops movement when the GUARD is opened,	No guards	N/A
	– absence or failure of one of their components prevents starting, and stops moving parts	No guards	N/A
	Movable GUARDS complied with all applicable tests as confirmed by review of RISK MANAGEMENT FILE	No guards	N/A
9.2.2.4.4	Protective measures provided in control system prevented moving parts from starting to move while in reach of persons ..... :	See Appended RM Results Table 9.2.2.4.4	N/A
	– protective measures prevented TRAPPING ZONE from reach, or, when it was reached, system movement stopped once ME EQUIPMENT started to move, and in the latter case, no HAZARD or damage resulted	No trapping zone	N/A
	– when protective measure was in a SINGLE FAULT CONDITION, and an unacceptable RISK could arise, one or more emergency stopping device(s) provided	No trapping zone	N/A
	RISK MANAGEMENT FILE reviewed and all conditions confirmed	No trapping zone	N/A
9.2.2.5	Continuous activation		N/A
	TRAPPING ZONE not considered to present a MECHANICAL HAZARD where impractical to make TRAPPING ZONE inaccessible when:	No trapping zone	N/A
	a) movement was in OPERATOR'S field of view	No trapping zone	N/A
	b) movement of ME EQUIPMENT or its parts was possible only by continuous activation of control by OPERATOR as long as OPERATOR response to deactivate device relied upon to prevent HARM	No trapping zone	N/A

IEC 60601-1			
Clause	Requirement + Test	Result - Remark	Verdict
	Manually operated movements complied with this clause since mass and velocity allowed adequate control of positioning without causing an unacceptable RISK	No trapping zone	N/A
	c) when in a SINGLE FAULT CONDITION of continuous activation system an unacceptable RISK could arise, one or more emergency stopping device(s) provided in ME EQUIPMENT . :	See Appended RM Results Table 9.2.2.5 c)	N/A
9.2.2.6	Speed of movement(s) positioning parts of ME EQUIPMENT or PATIENT, when contact with ME EQUIPMENT could result in a HAZARDOUS SITUATION, limited to allow OPERATOR control of positioning without resulting in an unacceptable RISK..... :	See Appended RM Results Table 9.2.2.6	N/A
	Over travel (stopping distance) of such movement occurring after operation of a control to stop movement, did not result in an unacceptable RISK	No trapping zone	N/A
9.2.3	Other HAZARDS associated with moving parts		N/A
9.2.3.1	Controls positioned, recessed, or protected by other means and could not be accidentally actuated to result in unacceptable RISK, except when ergonomic considerations for a PATIENT with special needs require otherwise	No moving parts	N/A
9.2.3.2	RISK due to over travel (past range limits) of ME EQUIPMENT parts reduced to an acceptable level, and stops or other means with mechanical strength to withstand intended loading in NORMAL USE and foreseeable misuse provided limiting measure in NORMAL and SINGLE FAULT CONDITION..... :	See appended Table 8.10 and Appended RM Results Table 9.2.3.2	N/A
9.2.4	Emergency stopping devices		N/A
	Where necessary to have one or more emergency stopping device(s), emergency stopping device complied with all the following, except for actuating switch capable of interrupting all power..... :	No such device See Appended RM Results Table 9.2.4	N/A
	a) Emergency stopping device reduced RISK to an acceptable level	As above	N/A
	b) Proximity and response of OPERATOR to actuate emergency stopping device could be relied upon to prevent HARM	As above	N/A
	c) Emergency stopping device actuator was readily accessible to OPERATOR	As above	N/A
	d) Emergency stopping device(s) are not part of normal operation of ME EQUIPMENT	As above	N/A



IEC 60601-1			
Clause	Requirement + Test	Result - Remark	Verdict
	e) Emergency switching operation or stopping means neither introduced further HAZARD nor interfered with operation necessary to remove original HAZARD	As above	N/A
	f) Emergency stopping device was able to break full load of relevant circuit, including possible stalled motor currents and the like	As above	N/A
	g) Means for stopping of movements operate as a result of one single action	As above	N/A
	h) Emergency stopping device provided with an actuator in red and easily distinguishable and identifiable from other controls	As above	N/A
	i) An actuator interrupting/opening mechanical movements marked on or immediately adjacent to face of actuator with symbol 18 of Table D.1 (symbol IEC 60417-5638, DB:2002-10) or "STOP"	As above	N/A
	j) Emergency stopping device, once actuated, maintained ME EQUIPMENT in disabled condition until a deliberate action, different from that used to actuate it, was performed	As above	N/A
	k) Emergency stopping device is suitable for its application	As above	N/A
9.2.5	Means provided to permit quick and safe release of PATIENT in event of breakdown of ME EQUIPMENT or failure of power supply, activation of a protective measure, or emergency stopping, and	See Appended RM Results Table 9.2.5	N/A
	– Uncontrolled or unintended movement of ME EQUIPMENT that could result in an unacceptable RISK prevented	No such risk	N/A
	– Situations where PATIENT is subjected to unacceptable RISKS due to proximity of moving parts, removal of normal exit routes, or other HAZARDS prevented	As above	N/A
	– Measures provided to reduce RISK to an acceptable level when after removal of counterbalanced parts, other parts of ME EQUIPMENT can move in a hazardous way	As above	N/A
9.3	Rough surfaces, sharp corners and edges of ME EQUIPMENT that could result in an unacceptable RISK avoided or covered .....	See Appended RM Results Table 9.3 No rough surfaces, sharp corners and edges	Pass
9.4	Instability HAZARDS		Pass

IEC 60601-1			
Clause	Requirement + Test	Result - Remark	Verdict
9.4.1	ME EQUIPMENT, other than FIXED and hand-held, for placement on a surface did not overbalance (tip over) or move unexpectedly, to the degree that it could present an unacceptable RISK to PATIENT, or OPERATOR as tested in 9.4.2 to 9.4.4	Not overbalanced	Pass
9.4.2	Instability – overbalance		Pass
9.4.2.1	ME EQUIPMENT or its parts did not overbalance when prepared per ACCOMPANYING DOCUMENTS, or when not specified, as in 9.4.2.2, and placed on a 10° inclined plane from horizontal consisting of a hard and flat surface (e.g., concrete floor covered with 2 to 4 mm thick vinyl material) .....	See Appended Table 9.4.2.1	Pass
9.4.2.2	Instability excluding transport		Pass
	ME EQUIPMENT or its parts prepared based on a) to g), inclusive, did not overbalance when placed in different positions of NORMAL USE, except transport positions, on a 5° inclined plane from horizontal (hard and flat surface)	See Appended Table 9.4.2.2	Pass
	A warning provided, stating “Transport only under conditions described in instructions for use or marked on ME EQUIPMENT with an indication of RESIDUAL RISK if ME EQUIPMENT or its parts overbalances” when overbalance occurred during 10° inclined plane test	Not overbalanced	Pass
9.4.2.3	Instability from horizontal and vertical forces		N/A
	a) ME EQUIPMENT with a mass of 25 kg or more, other than FIXED ME EQUIPMENT for use on floor, did not overbalance due to pushing or resting	Not intended for use on floor	N/A
	Surfaces of ME EQUIPMENT where a RISK of overbalancing exists from pushing, leaning, resting etc., permanently marked with a CLEARLY LEGIBLE warning of the RISK (e.g., safety sign 5 of Table D.2, safety sign ISO 7010-P017)	As above	N/A
	ME EQUIPMENT did not overbalance when placed on a horizontal plane, and a force of 25% of its weight, but not more than 220 N, applied in different directions, except a direction with an upward component	As above	N/A
	b) ME EQUIPMENT, other than FIXED ME EQUIPMENT, for use on the floor or on a table, did not overbalance due to sitting or stepping, except when a legible warning of this RISK provided on ME EQUIPMENT (e.g., safety signs 6 and 7 of Table D.2, safety signs ISO 7010-P018, or ISO 7010-P019 as appropriate)	As above	N/A

IEC 60601-1			
Clause	Requirement + Test	Result - Remark	Verdict
	<b>ME EQUIPMENT did not overbalance when placed on a horizontal plane, and a constant force of 800 N applied at the point of maximum moment to working surfaces, offering an foothold or sitting surface of a min 20 x 20 cm area, and at a height <math>\leq</math> 1 m from the floor .....</b> :	As above	N/A
<b>9.4.2.4</b>	<b>Castors and wheels</b>		N/A
<b>9.4.2.4.1</b>	<b>Means used for transportation of MOBILE ME EQUIPMENT (e.g., castors or wheels) did not result in an unacceptable RISK when MOBILE ME EQUIPMENT moved or parked in NORMAL USE</b>	Not mobile	N/A
<b>9.4.2.4.2</b>	<b>Force required to move MOBILE ME EQUIPMENT along a hard and flat horizontal surface did not exceed 200 N applied at a height of 1 m above floor or highest point on ME EQUIPMENT when <math>&lt;</math> 1 m high, except when instructions indicated more than one person needed (N) .....</b> :	See Appended Table 9.4.2.4.2	N/A
<b>9.4.2.4.3</b>	<b>MOBILE ME EQUIPMENT exceeding 45 kg configured with a SAFE WORKING LOAD, moved 10 times in forward direction over a solid vertical plane obstruction with wheels impacting the obstruction at a speed of 0.4 m/s <math>\pm</math> 0.1 m/s for manual or with max speed for motor driven MOBILE ME EQUIPMENT .....</b> :	See Appended Table 9.4.2.4.3	N/A
	<b>ME EQUIPMENT went up the obstruction without overbalancing or any other unacceptable RISK as determined by examination of RISK MANAGEMENT FILE, ME EQUIPMENT and its parts...</b> :	See Appended RM Results Table 9.4.2.3	N/A
	<b>There was no reduction of CREEPAGE and CLEARANCES below 8.9, no access to parts exceeding limits in 8.4, and no access to moving parts capable of causing HARM, and</b>	Not mobile	N/A
	<b>– Assessment criteria in Clause 9 and 11.6 used</b>	As above	N/A
	<b>– Dielectric strength test of 8.8.3 conducted to evaluate integrity of solid SUPPLEMENTARY or REINFORCED INSULATION</b>	As above	N/A
	<b>– CREEPAGE DISTANCES and AIR CLEARANCES measured compared favourably with min distances in clause 8.9</b>	As above	N/A
	<b>Small chips not adversely affecting protection against electric shock or moisture, disregarded</b>	Not required	N/A
<b>9.4.3</b>	<b>Instability from unwanted lateral movement (including sliding)</b>		N/A
<b>9.4.3.1</b>	<b>a) Brakes of power-driven MOBILE ME EQUIPMENT normally activated and could only be released by continuous actuation of a control</b>	No power-driven mobile equipment	N/A

IEC 60601-1			
Clause	Requirement + Test	Result - Remark	Verdict
	<b>b) MOBILE ME EQUIPMENT provided with locking means to prevent unwanted movements of ME EQUIPMENT or its parts in transport position</b>	Not mobile	N/A
	<b>c) No unacceptable RISK due to unwanted lateral movement resulted when MOBILE ME EQUIPMENT placed in its transport position or worst case NORMAL USE position with SAFE WORKING LOAD, and locking device activated, on a 10° inclined hard flat surface with castors in the worst-case position</b>	As above	N/A
	<b>Following initial elastic movement, creepage, and pivoting of castors, no further movement of MOBILE ME EQUIPMENT &gt; 50 mm (in relation to inclined plane) occurred (mm) ..... :</b>	See Appended Table 9.4.3.1	N/A
	<b>RISK due to any initial movement assessed taking into consideration NORMAL USE of ME EQUIPMENT</b>	As above	N/A
<b>9.4.3.2</b>	<b>Instability excluding transport</b>		N/A
	<b>a) Further movement of ME EQUIPMENT (after initial elastic movement) was less than 50 mm when MOBILE ME EQUIPMENT with a SAFE WORKING LOAD positioned on a 5° inclined hard flat surface with wheel locked or braking system activated (mm) ..... :</b>	See Appended Table 9.4.3.2	N/A
	<b>RISK due to initial movements assessed taking into consideration NORMAL USE of ME EQUIPMENT</b>	Not mobile	N/A
	<b>b) TRANSPORTABLE or STATIONARY ME EQUIPMENT for use on the floor and with a SAFE WORKING LOAD prepared as in 9.4.2.2 and placed on a horizontal plane with locking device activated and castors, when supplied, in their worst – case position</b>	As above	N/A
	<b>Further movement of ME EQUIPMENT (after initial elastic movement), was no more than 50 mm when a force of 25 % of weight of unit, but less than 220 N, applied in different directions, except a direction with an upwards component, at highest point of ME EQUIPMENT but ≤ 1.5 m from floor..... :</b>	See Appended Table 9.4.3.2	N/A
	<b>RISK due to initial movements assessed taking into consideration NORMAL USE of ME EQUIPMENT</b>	As above	N/A
<b>9.4.4</b>	<b>Grips and other handling devices</b>		N/A

IEC 60601-1			
Clause	Requirement + Test	Result - Remark	Verdict
	a) ME EQUIPMENT other than PORTABLE EQUIPMENT or its part with a mass of over 20 kg requiring lifting in NORMAL USE or transport provided with suitable handling means, or ACCOMPANYING DOCUMENTS specify safe lifting method, except when handling is obvious and not causing HAZARDS	Not intended to be lifted	N/A
	Handles, when supplied, suitably placed to enable ME EQUIPMENT or its part to be carried by two or more persons and by examination of EQUIPMENT, its part, or ACCOMPANYING DOCUMENTS	As above	N/A
	b) PORTABLE ME EQUIPMENT with a mass > 20 kg provided with one or more carrying-handles suitably placed to enable carrying by two or more persons as confirmed by actual carrying	As above	N/A
	c) Carrying handles and grips and their means of attachment withstood loading test..... :	See Appended Table 9.4.4	N/A
9.5	Expelled parts HAZARD		N/A
9.5.1	Suitability of means of protecting against unacceptable RISK of expelled parts determined by assessment and examination of RISK MANAGEMENT FILE..... :	See Appended RM Results Table 9.5.1	N/A
9.5.2	Cathode ray tube(s) complied with IEC 60065:2001, Clause 18, or IEC 61965..... :	See appended Table 8.10	N/A
9.6	Acoustic energy (including infra- and ultrasound) and vibration		N/A
9.6.1	Human exposure to acoustic energy and vibration from ME EQUIPMENT doesn't result in unacceptable RISK as confirmed in RISK MANAGEMENT FILE including audibility of auditory alarm signals, PATIENT sensitivity, and tests of 9.6.2 and 9.6.3 .....	See Appended RM Results Table 9.6.1	N/A
9.6.2	Acoustic energy		N/A
9.6.2.1	PATIENT, OPERATOR, and other persons are not exposed to acoustic energy from ME EQUIPMENT in NORMAL USE, except for auditory alarm signals	No Acoustic energy	N/A
	– 80 dBA for a cumulative exposure of 24 h over a 24 h period (dBA) .....	No Acoustic energy	—
	- 83 dBA (when halving the cumulative exposure time) (dBA) .....	No Acoustic energy	—
	– 140 dB un-weighted sound pressure level for impulsive or impact acoustic energy (dB) .....	No Acoustic energy	—
9.6.2.2	RISK MANAGEMENT FILE examined for RISKS associated with infrasound or ultrasound, when present, addressed in RISK MANAGEMENT PROCESS	See Appended RM Results Table 9.6.2.2	N/A

IEC 60601-1			
Clause	Requirement + Test	Result - Remark	Verdict
9.6.3	<b>Hand-transmitted vibration</b>		N/A
	<b>Means provided, except for INTENDED USE vibrations, to protect PATIENT and OPERATOR when hand-transmitted frequency-weighted r.m.s. acceleration generated in NORMAL USE exceeds specified values measured at points of hand contact with PATIENT or OPERATOR</b>	No vibration	N/A
	<b>– 2.5 m/s<sup>2</sup> for a cumulative time of 8 h during a 24 h period (m/s<sup>2</sup>)..... :</b>	As above	N/A
	<b>– Accelerations for different times, inversely proportional to square root of time (m/s<sup>2</sup>) .....</b>	As above	N/A
9.7	<b>Pressure vessels and parts subject to pneumatic and hydraulic pressure</b>		N/A
9.7.1	<b>Requirements of this clause applied to vessels and parts of ME EQUIPMENT subject to pressure resulting in rupture and unacceptable RISK</b>	There are not vessels and parts subject to pressure, the rupture of which could cause a safety hazard	N/A
	<b>Parts of a pneumatic or hydraulic system used as a support system, comply with 9.8</b>	As above	N/A
9.7.2	<b>Pneumatic and hydraulic parts of ME EQUIPMENT or ACCESSORIES met following requirements based on examination of RISK MANAGEMENT FILE .....</b>	See Appended RM Results Table 9.7.2	N/A
	<b>– No unacceptable RISK resulted from loss of pressure or loss of vacuum</b>	As above	N/A
	<b>– No unacceptable RISK resulted from a fluid jet caused by leakage or a component failure</b>	As above	N/A
	<b>– Elements of ME EQUIPMENT or an ACCESSORY, especially pipes and hoses leading to an unacceptable RISK protected against harmful external effects</b>	As above	N/A
	<b>– Reservoirs and similar vessels leading to an unacceptable RISK are automatically depressurized when ME EQUIPMENT is isolated from its power supply</b>	As above	N/A
	<b>Means provided for isolation, or local depressurizing reservoirs and similar vessels, and pressure indication when above not possible</b>	As above	N/A
	<b>– All elements remaining under pressure after isolation of ME EQUIPMENT or an ACCESSORY from its power supply resulting in an unacceptable RISK provided with clearly identified exhaust devices, and a warning to depressurize these elements before setting or maintenance activity</b>	As above	N/A



IEC 60601-1			
Clause	Requirement + Test	Result - Remark	Verdict
9.7.3	Maximum pressure a part of ME EQUIPMENT can be subjected to in NORMAL and SINGLE FAULT CONDITIONS considered to be highest of following:	As above	N/A
	a) RATED maximum supply pressure from an external source	As above	N/A
	b) Pressure setting of a pressure-relief device provided as part of assembly	As above	N/A
	c) Max pressure that can develop by a source of pressure that is part of assembly, unless pressure limited by a pressure-relief device	As above	N/A
9.7.4	Max pressure in NORMAL and SINGLE FAULT CONDITIONS did not exceed MAXIMUM PERMISSIBLE WORKING PRESSURE for EQUIPMENT part, except as allowed in 9.7.7, confirmed by examination of ME EQUIPMENT and RISK MANAGEMENT FILE, and by functional tests .....	See Appended RM Results Table 9.7.4	N/A
9.7.5	A pressure vessel withstood a HYDRAULIC TEST PRESSURE when pressure was > 50 kPa, and product of pressure and volume was more than 200 kPaI .....	See Appended Table 9.7.5	N/A
9.7.6	Pressure-control device regulating pressure in ME EQUIPMENT with pressure-relief device completed 100,000 cycles of operation under RATED load and prevented pressure from exceeding 90 % of setting of pressure-relief device in different conditions of NORMAL USE . :	See Appended RM Results Table 9.7.6	N/A
9.7.7	Pressure-relief device(s) used where MAXIMUM PERMISSIBLE WORKING PRESSURE could otherwise be exceeded met the following, as confirmed by MANUFACTURER'S data, ME EQUIPMENT, RISK MANAGEMENT FILE, and functional tests .....	See Appended RM Results Table 9.7.7	N/A
	a) Connected as close as possible to pressure vessel or parts of system it is to protect	No pressure-relief device	N/A
	b) Installed to be readily accessible for inspection, maintenance, and repair	As above	N/A
	c) Could be adjusted or rendered inoperative without a TOOL	As above	N/A
	d) With discharge opening located and directed as to not to release material towards any person	As above	N/A
	e) With discharge opening located and directed as to not to deposit material on parts that could result in an unacceptable RISK	As above	N/A

IEC 60601-1			
Clause	Requirement + Test	Result - Remark	Verdict
	<b>f) Adequate discharge capacity provided to ensure that pressure will not exceed MAXIMUM PERMISSIBLE WORKING PRESSURE of system it is connected to by more than 10 % when failure occurs in control of supply pressure</b>	As above	N/A
	<b>g) No shut-off valve provided between a pressure-relief device and parts it is to protect</b>	As above	N/A
	<b>h) Min number of cycles of operation 100 000, except for one-time use devices (bursting disks)</b>	As above	N/A
<b>9.8</b>	<b>HAZARDS associated with support systems</b>		N/A
<b>9.8.1</b>	<b>ME EQUIPMENT parts designed to support loads or provide actuating forces when a mechanical fault could constitute an unacceptable RISK .. :</b>	See appended Table 8.10 and Appended RM Results Table 9.8.1	N/A
	<b>– Construction of support, suspension, or actuation system complied with Table 21 and TOTAL LOAD</b>	No support systems	N/A
	<b>– Means of attachment of ACCESSORIES prevent possibility of incorrect attachment that could result in an unacceptable RISK</b>	No support systems	N/A
	<b>– RISK ANALYSIS of support systems included HAZARDS from static, dynamic, vibration, impact and pressure loading, foundation and other movements, temperature, environmental, manufacture and service conditions</b>	No support systems	N/A
	<b>– RISK ANALYSIS included effects of failures such as excessive deflection, plastic deformation, ductile/brittle fracture, fatigue fracture, instability (buckling), stress-assisted corrosion cracking, wear, material creep and deterioration, and residual stresses from manufacturing PROCESSES</b>	No support systems	N/A
	<b>– Instructions on attachment of structures to a floor, wall, ceiling, included in ACCOMPANYING DOCUMENTS making adequate allowances for quality of materials used to make the connection and list the required materials</b>	No support systems	N/A
	<b>Additional instructions provided on checking adequacy of surface of structure parts will be attached to</b>	No support systems	N/A
<b>9.8.2</b>	<b>Support systems maintain structural integrity during EXPECTED SERVICE LIFE, and TENSILE SAFETY FACTORS are not less than in Table 21, except when an alternative method used to demonstrate structural integrity throughout EXPECTED SERVICE LIFE, or for a foot rest</b>	No support systems	N/A



IEC 60601-1			
Clause	Requirement + Test	Result - Remark	Verdict
	<b>Compliance with 9.8.1 and 9.8.2 confirmed by examination of ME EQUIPMENT, RISK MANAGEMENT FILE, specifications and material processing.. :</b>	See Appended RM Results Table 9.8.2	N/A
	<b>When test results were part of information, testing consisted of application of a test load to support assembly equal to TOTAL LOAD times required TENSILE SAFETY FACTOR while support assembly under test was in equilibrium after 1 min, or not resulted in an unacceptable RISK . :</b>	See appended Table 8.10	N/A
<b>9.8.3</b>	<b>Strength of PATIENT or OPERATOR support or suspension systems</b>		N/A
<b>9.8.3.1</b>	<b>ME EQUIPMENT parts supporting or immobilizing PATIENTS minimize RISK of physical injuries and accidental loosening of secured joints</b>	See Appended RM Results Table 9.8.3.1	N/A
	<b>SAFE WORKING LOAD of ME EQUIPMENT or its parts supporting or suspending PATIENTS or OPERATORS is sum of mass of PATIENTS or mass of OPERATORS plus mass of ACCESSORIES supported by ME EQUIPMENT or its parts</b>	No suspension systems	N/A
	<b>Supporting and suspending parts for adult human PATIENTS or OPERATORS designed for a PATIENT or OPERATOR with a min mass of 135 kg and ACCESSORIES with a min mass of 15 kg, unless stated by MANUFACTURER</b>	No suspension systems	N/A
	<b>Maximum mass of PATIENT included in SAFE WORKING LOAD of ME EQUIPMENT or its parts supporting or suspending PATIENTS adapted when MANUFACTURER specified applications</b>	No suspension systems	N/A
	<b>Max allowable PATIENT mass &lt; 135 kg marked on ME EQUIPMENT and stated in ACCOMPANYING DOCUMENTS</b>	No suspension systems	N/A
	<b>Max allowable PATIENT mass &gt; 135 kg stated in ACCOMPANYING DOCUMENTS</b>	No suspension systems	N/A
	<b>Examination of markings, ACCOMPANYING DOCUMENTS, and RISK MANAGEMENT FILE confirmed compliance .....</b>	See copy of Marking Label	N/A
<b>9.8.3.2</b>	<b>Part of SAFE WORKING LOAD representing mass of PATIENTS or OPERATORS is distributed on support/suspension surface representing human body as in Fig A.19</b>	No suspension systems	N/A
	<b>Part of SAFE WORKING LOAD representing mass of ACCESSORIES deployed as in NORMAL USE and, when not defined, at worst case position permitted by configuration or ACCESSORIES attachment on support/suspension parts</b>	No suspension systems	N/A

IEC 60601-1			
Clause	Requirement + Test	Result - Remark	Verdict
	a) Entire mass of PATIENT or OPERATOR distributed over an area of 0.1 m <sup>2</sup> on a foot rest temporarily supporting a standing PATIENT or OPERATOR .....	See Appended RM Results Table 9.8.3.2 a)	N/A
	Compliance confirmed by examination of ME EQUIPMENT, RISK MANAGEMENT FILE, specifications of materials and their processing, and tests ..	See appended Table 8.10	N/A
	PATIENT support/suspension system positioned horizontally in most disadvantageous position in NORMAL USE, and a mass 2 x 135 kg or twice intended person's load (the greater used), applied to foot rest over an area of 0.1 m <sup>2</sup> for 1 min (Kg) .....	See appended Table 9.8.3.2	N/A
	Damage or deflection resulting in an unacceptable RISK did not occur on foot rest and its secured joints	No suspension systems	N/A
	b) Deflection of a support surface from PATIENT or OPERATOR loading on an area of support/ suspension where a PATIENT or OPERATOR can sit did not result in an unacceptable RISK .....	See Appended RM Results Table 9.8.3.2 b)	N/A
	Compliance confirmed by examination of ME EQUIPMENT, RISK MANAGEMENT FILE, specifications of materials and their processing, and by a test .....	See appended Table 8.10	N/A
	PATIENT support/suspension system set in most unfavourable NORMAL USE position, and a mass of 60 % of part of SAFE WORKING LOAD simulating PATIENT or OPERATOR, or a min 80 kg, placed on support or suspension system with centre of load 60 mm from outer edge of support or suspension system for at least one minute (Kg) .....	See appended Table 9.8.3.2	N/A
	Deflection of support/suspension system resulting in an unacceptable RISK not occur	No suspension systems	N/A
9.8.3.3	Dynamic forces that can be exerted on equipment parts supporting or suspending a PATIENT or OPERATOR in NORMAL USE did not result in an unacceptable RISK as confirmed by following test:	No suspension systems	N/A
	PATIENT support/suspension system set in most unfavourable NORMAL USE position, and a mass equal to SAFE WORKING LOAD simulating PATIENT or OPERATOR dropped from 150 mm above seat area on an area of support/ suspension a PATIENT or OPERATOR can sit .....	See appended Table 9.8.3.3	N/A
9.8.4	Systems with MECHANICAL PROTECTIVE DEVICES		N/A

IEC 60601-1			
Clause	Requirement + Test	Result - Remark	Verdict
9.8.4.1	a) A MECHANICAL PROTECTIVE DEVICE provided when a support system or its parts impaired by wear have a TENSILE SAFETY FACTOR $\geq$ to values in Table 21, rows 5 and 6, but less than 3 and 4 :	See Appended RM Results Table 9.8.4.1	N/A
	b) MECHANICAL PROTECTIVE complies with the requirements as follows:	No such systems	N/A
	– Designed based on TOTAL LOAD, and includes effects of SAFE WORKING LOAD when applicable	No such systems	N/A
	– Has TENSILE SAFETY FACTORS for all parts not less than Table 21, row 7	No such systems	N/A
	– Activated before travel (movement) produced an unacceptable RISK	No such systems	N/A
	– Takes into account Clauses 9.2.5 and 9.8.4.3	No such systems	N/A
	Compliance confirmed by examination of ME EQUIPMENT, RISK MANAGEMENT FILE, specifications of materials and their processing ..... :	See appended Table 8.10	N/A
9.8.4.2	Activation of MECHANICAL PROTECTIVE DEVICE is made obvious to OPERATOR when ME EQUIPMENT can still be used after failure of suspension or actuation means and activation of a MECHANICAL PROTECTIVE DEVICE (e.g., a secondary cable)	No such systems	N/A
	MECHANICAL PROTECTIVE DEVICE requires use of a TOOL to be reset or replaced	No such systems	N/A
9.8.4.3	MECHANICAL PROTECTIVE DEVICE intended to function once		N/A
	– Further use of ME EQUIPMENT not possible until replacement of MECHANICAL PROTECTIVE DEVICE :	See Appended RM Results Table 9.8.4.3	N/A
	– ACCOMPANYING DOCUMENTS instruct once MECHANICAL PROTECTIVE DEVICE is activated, SERVICE PERSONNEL shall be called, and MECHANICAL PROTECTIVE DEVICE must be replaced before ME EQUIPMENT can be used	No such systems	N/A
	– ME EQUIPMENT permanently marked with safety sign 2 of Table D.2 (i.e., safety sign 7010-W001)	No such systems	N/A
	– Marking is adjacent to MECHANICAL PROTECTIVE DEVICE or its location relative to MECHANICAL PROTECTIVE DEVICE is obvious to service personnel	No such systems	N/A
	– Compliance confirmed by examination of ME EQUIPMENT, ACCOMPANYING DOCUMENTS, RISK MANAGEMENT FILE, specifications and processing of materials, and following test..... :	See appended Table 8.10	N/A

IEC 60601-1			
Clause	Requirement + Test	Result - Remark	Verdict
	A chain, cable, band, spring, belt, jack screw nut, pneumatic or hydraulic hose, structural part or the like, employed to support a load, defeated by a convenient means causing maximum normal load to fall from most adverse position permitted by construction of ME EQUIPMENT	No such systems	N/A
	Load included SAFE WORKING LOAD in 9.8.3.1 when system was capable of supporting a PATIENT or OPERATOR	No such systems	N/A
	No evidence of damage to MECHANICAL PROTECTIVE DEVICE affecting its ability to perform its intended function	No such systems	N/A
9.8.5	Systems without MECHANICAL PROTECTIVE DEVICES		N/A
	Support system parts have TENSILE SAFETY FACTORS $\geq$ to values in Table 21, rows 1 and 2, and are not impaired by wear .....	See Appended RM Results Table 9.8.5	N/A
	Support system parts impaired by wear, however, they have TENSILE SAFETY FACTORS $\geq$ to values in Table 21, rows 3 and 4	No support systems	N/A
	Examination of ME EQUIPMENT and RISK MANAGEMENT FILE confirmed compliance	No support systems	N/A

10	PROTECTION AGAINST UNWANTED AND EXCESSIVE RADIATION HAZARDS		N/A
10.1	X-Radiation		N/A
10.1.1	X-radiation dose-rate was $\leq 36 \mu\text{A/kg}$ ( $5 \mu\text{Sv/h}$ ) ( $0.5 \text{ mR/h}$ ) 5 cm from surface of ME EQUIPMENT including background radiation for ME EQUIPMENT not producing therapeutic/diagnostic X-radiation but producing ionizing radiation ..	See Table 10.1.1	N/A
	Amount of radiation measured by means of an ionizing chamber radiation monitor with an effective area of $10 \text{ cm}^2$ or by other instruments producing equal results	No X-radiation	N/A
	ME EQUIPMENT operated as in NORMAL USE at most unfavourable RATED MAINS VOLTAGE and controls adjusted to emit maximum radiation	No X-radiation	N/A
	Internal pre-set controls not intended for adjustment during EXPECTED SERVICE LIFE of ME EQUIPMENT not taken into consideration	No X-radiation	N/A
10.1.2	RISK from unintended X-radiation from ME EQUIPMENT producing X-radiation for diagnostic and therapeutic purposes addressed in RISK MANAGEMENT PROCESS as indicated in RISK MANAGEMENT FILE (see IEC 60601-1-3 & 1.3) .....	See Appended RM Results Table 10.1.2	N/A



IEC 60601-1			
Clause	Requirement + Test	Result - Remark	Verdict
10.2	Risk associated with alpha, beta, gamma, neutron, and other particle radiation, when applicable, addressed in RISK MANAGEMENT PROCESS as shown in RISK MANAGEMENT FILE .....	See Appended RM Results Table 10.2	N/A
10.3	Risk associated with microwave radiation, when applicable, addressed in RISK MANAGEMENT PROCESS as indicated in RISK MANAGEMENT FILE .....	See Appended RM Results Table 10.3	N/A
10.4	Relevant requirements of IEC 60825-1:1993 applied to lasers, light emitting diodes (LEDs), and laser light barriers or similar products	No such radiation	N/A
10.5	Risk associated with visible electromagnetic radiation other than emitted by lasers and LEDs, when applicable, addressed in RISK MANAGEMENT PROCESS as indicated in RISK MANAGEMENT FILE .....	See Appended RM Results Table 10.5	N/A
10.6	RISK associated with infrared radiation other than emitted by lasers and LEDs, as applicable, addressed in RISK MANAGEMENT PROCESS as indicated in RISK MANAGEMENT FILE .....	See Appended RM Results Table 10.6	N/A
10.7	RISK associated with ultraviolet radiation other than emitted by lasers and LEDs, as applicable, addressed in RISK MANAGEMENT PROCESS as indicated in RISK MANAGEMENT FILE..... :	See Appended RM Results Table 10.7	N/A

11	<b>PROTECTION AGAINST EXCESSIVE TEMPERATURES AND OTHER HAZARDS</b>		Pass
11.1	<b>Excessive temperatures in ME EQUIPMENT</b>		Pass
11.1.1	Temperatures on ME EQUIPMENT parts did not exceed values in Tables 22 and 23 operating in worst-case NORMAL USE at maximum rated ambient operating temperature T .....	See appended Table 11.1.1 and appended RM Results Table 11.1.1	Pass
	Surfaces of test corner did not exceed 90 °C		N/A
	THERMAL CUT-OUTS did not operate in NORMAL CONDITION	No thermal cut-outs	N/A
11.1.2	<b>Temperature of APPLIED PARTS</b>		Pass
11.1.2.1	Temperatures, hot or cold surfaces, and when appropriate, clinical effects of APPLIED PARTS supplying heat to a PATIENT determined and documented in RISK MANAGEMENT FILE and instructions for use .....	See appended Table 11.1.2.1 and appended RM Results Table 11.1.2.1	Pass
11.1.2.2	APPLIED PARTS not supplying heat to a PATIENT met Table 24 with max surface temperatures > 41 °C disclosed in instructions for use, and clinical effects regarding maturity of PATIENTS, body surface, surface pressure, medications taken, as shown in RISK MANAGEMENT FILE .....	See appended Table 11.1.2.2 and appended RM Results Table 11.1.2.2	Pass



IEC 60601-1			
Clause	Requirement + Test	Result - Remark	Verdict
	Surfaces of APPLIED PARTS cooled below ambient temperatures that can also result in HAZARD evaluated as part of RISK MANAGEMENT PROCESS	No such applied parts	N/A
11.1.3	Measurements not made when engineering judgment and rationale by MANUFACTURER indicated temperature limits could not exceed, as documented in RISK MANAGEMENT FILE .....	See appended Table 11.1.3 and RM Results Table 11.1.3	Pass
	Test corner not used where engineering judgment and rationale by MANUFACTURER indicated test corner will not impact measurements, as documented in RISK MANAGEMENT FILE	See appended Table 11.1.3 and RM Results Table 11.1.3	Pass
	Probability of occurrence and duration of contact for parts likely to be touched and for APPLIED PARTS documented in RISK MANAGEMENT FILE	See appended Table 11.1.3 and RM Results Table 11.1.3	Pass
11.1.4	GUARDS preventing contact with hot or cold accessible surfaces removable only with a TOOL	Complied	Pass
11.2	Fire prevention		Pass
11.2.1	ENCLOSURE has strength and rigidity necessary to prevent a fire caused by reasonably foreseeable misuse and met mechanical strength tests for ENCLOSURES in 15.3	Complied	Pass
11.2.2	Me equipment and me systems used in conjunction with OXYGEN RICH ENVIRONMENTS		N/A
11.2.2.1	RISK of fire in an OXYGEN RICH ENVIRONMENT reduced by means limiting spread of fire under NORMAL or SINGLE FAULT CONDITIONS when source of ignition in contact with ignitable material .. :	See appended Table 8.10	N/A
	Requirements of 13.1.1 applied to oxygen concentrations up to 25 % at one atmosphere or partial pressures up to 27.5 kPa for higher atmospheric pressures	Unit is not intended for such environment	N/A
	a) No sources of ignition discovered in an OXYGEN RICH ENVIRONMENT in NORMAL and SINGLE FAULT CONDITIONS under any of the following conditions..... :	Unit is not intended for such environment	N/A
	1) when temperature of material raised to its ignition temperature	Unit is not intended for such environment	N/A
	2) when temperatures affected solder or solder joints causing loosening, short circuiting, or other failures causing sparking or increasing material temperature to its ignition temperature	Unit is not intended for such environment	N/A



IEC 60601-1			
Clause	Requirement + Test	Result - Remark	Verdict
	<b>3) when parts affecting safety cracked or changed outer shape exposing temperatures higher than 300°C or sparks due to overheating</b>	Unit is not intended for such environment	N/A
	<b>4) when temperatures of parts or components exceeded 300°C, atmosphere was 100 % oxygen, contact material solder, and fuel cotton</b>	Unit is not intended for such environment	N/A
	<b>5) when sparks provided adequate energy for ignition by exceeding limits of Figs 35 to 37 (inclusive), atmosphere was 100 % oxygen, contact material solder, and fuel cotton</b>	Unit is not intended for such environment	N/A
	<b>Deviations from worst case limits in 4) and 5) above based on lower oxygen concentrations or less flammable fuels justified and documented in RISK MANAGEMENT FILE</b>	See Appended RM Results Table 11.2.2.1	N/A
	<b>Alternative test in this clause did not identify existence of ignition sources at highest voltage or current, respectively .....</b>	See appended Table 11.2.2.1	N/A
	<b>A safe upper limit determined by dividing upper limit of voltage or current, respectively, with safety margin factor of three.....</b>	Unit is not intended for such environment	N/A
	<b>b) RESIDUAL RISK of fire in an OXYGEN RICH ENVIRONMENT as determined by application of RISK MANAGEMENT PROCESS is based on following configurations, or in combination .....</b>	See Appended RM Results Table 11.2.2.1	N/A
	<b>1) Electrical components in an OXYGEN RICH ENVIRONMENT provided with power supplies having limited energy levels lower than those considered sufficient for ignition in 11.2.2.1 a) as determined by examination, measurement or calculation of power, energy, and temperatures in NORMAL and SINGLE FAULT CONDITIONS identified in 11.2.3.....</b>	See appended Tables 4.11, 11.1.1 to 11.1.2.2, inclusive; and Table 13.2	N/A
	<b>2) Max oxygen concentration measured until it did not exceed 25 % in ventilated compartments with parts that can be a source of ignition only in SINGLE FAULT CONDITION and can be penetrated by oxygen due to an undetected leak (%).....</b>	Unit is not intended for such environment	N/A
	<b>3) A compartment with parts or components that can be a source of ignition only under SINGLE FAULT CONDITION separated from another compartment containing an OXYGEN RICH ENVIRONMENT by sealing all joints and holes for cables, shafts, or other purposes</b>	Unit is not intended for such environment	N/A

IEC 60601-1			
Clause	Requirement + Test	Result - Remark	Verdict
	<b>Effect of possible leaks and failures under SINGLE FAULT CONDITION that could cause ignition evaluated using a RISK ASSESSMENT to determine maintenance intervals by examination of documentation and RISK MANAGEMENT FILE..... :</b>	See Attachment #	N/A
	<b>4) Fire initiated in ENCLOSURE of electrical components in a compartment with OXYGEN RICH ENVIRONMENT that can become a source of ignition only under SINGLE FAULT CONDITIONS self-extinguished rapidly and no hazardous amount of toxic gases reached PATIENT as determined by analysis of gases .....</b>	See Attachment #	N/A
11.2.2.2	<b>RISK of ignition under least favourable conditions did not occur and oxygen concentration did not exceed 25% in immediate surroundings due to location of external exhaust outlets of an OXYGEN RICH ENVIRONMENT when electrical components mounted outside of ME EQUIPMENT or ME SYSTEM</b>	Unit is not intended for such environment	N/A
11.2.2.3	<b>Electrical connections within a compartment containing an OXYGEN RICH ENVIRONMENT under NORMAL USE did not produce sparks due to loosening or breaking, except when limited in power and energy to values in 11.2.2.1 a) 5)</b>	Unit is not intended for such environment	N/A
	<b>– Screw-attachments protected against loosening during use by varnishing, use of spring washers, or adequate torques</b>	Unit is not intended for such environment	N/A
	<b>– Soldered, crimped, and pin-and-socket connections of cables exiting ENCLOSURE include additional mechanical securing means</b>	Unit is not intended for such environment	N/A
11.2.3	<b>SINGLE FAULT CONDITIONS related to OXYGEN RICH ENVIRONMENTS ME EQUIPMENT and ME SYSTEMS considered</b>		N/A
	<b>– Failure of a ventilation system constructed in accordance with 11.2.2.1 b) 2)..... :</b>	Unit is not intended for such environment	N/A
	<b>– Failure of a barrier constructed in accordance with 11.2.2.1 b) 3)..... :</b>	Unit is not intended for such environment	N/A
	<b>– Failure of a component creating a source of ignition (as defined in 11.2.2.1 a) .....</b>	Unit is not intended for such environment	N/A
	<b>– Failure of solid insulation or creepage and clearances providing equivalent of at least one MEANS OF PATIENT PROTECTION but less than two MEANS OF PATIENT PROTECTION that could create a source of ignition defined in 11.2.2.1 a) .....</b>	Unit is not intended for such environment	N/A
	<b>– Failure of a pneumatic component resulting in leakage of oxygen-enriched gas..... :</b>	Unit is not intended for such environment	N/A
11.3	<b>Constructional requirements for fire ENCLOSURES of ME EQUIPMENT</b>		Pass

IEC 60601-1			
Clause	Requirement + Test	Result - Remark	Verdict
	<b>ME EQUIPMENT met this clause for alternate means of compliance with selected HAZARDOUS SITUATIONS and fault conditions in 13.1.2..... :</b>	See Appended RM Results Table 11.3	Pass
	<b>Constructional requirements were met, or</b>	Complied	Pass
	<b>- constructional requirements specifically analysed in RISK MANAGEMENT FILE .....</b> :	See Appended RM Results Table 11.3	N/A
	<b>Justification, when requirement not met .....</b> :	See Appended RM Results Table 11.3	N/A
	<b>a) Flammability classification of insulated wire within fire ENCLOSURE is FV-1, or better, based on IEC 60695 series as determined by examination of data on materials</b>	See appended Table 8.10	Pass
	<b>Flammability classification of connectors, printed circuit boards, and insulating material on which components are mounted is FV-2, or better, based on IEC 60695-11-10 as decided by examination of materials data .....</b> :	See appended Table 8.10	Pass
	<b>If no FV Certification, FV tests based on IEC 60695-11-10 conducted on 3 samples of complete parts (or sections of it), including area with min. thickness, ventilation openings</b>		N/A
	<b>b) Fire ENCLOSURE met following:</b>	Comply with 11.3	Pass
	<b>1) No openings at bottom or, as specified in Fig 39, constructed with baffles as in Fig 38, or made of perforated metal as in Table 25, or a metal screen with a mesh <math>\leq 2 \times 2</math> mm centre to centre and wire diameter of at least 0.45 mm</b>	No openings at bottom	Pass
	<b>2) No openings on the sides within the area included within the inclined line C in Fig 39</b>	No such openings on the sides	Pass
	<b>3) ENCLOSURE, baffles, and flame barriers have adequate rigidity and made of appropriate metal or of non-metallic materials, except constructions based on Table 25 and a mesh; FV-2 or better for TRANSPORTABLE ME EQUIPMENT, FV-1 or better for fixed EQUIPMENT, or STATIONARY EQUIPMENT per IEC 60695-11-10, determined by ENCLOSURE examination or flammability classification based on 11.3a)..... :</b>	See appended Table 8.10	Pass
<b>11.4</b>	<b>ME EQUIPMENT and ME SYSTEMS intended for use with flammable anaesthetics</b>		N/A
	<b>ME EQUIPMENT, ME SYSTEMS and parts described in ACCOMPANYING DOCUMENTS for use with flammable anaesthetics (CATEGORY AP) or anaesthetics with oxidants (CATEGORY APG) comply with Annex G</b>	Not intended for this application	N/A
<b>11.5</b>	<b>ME EQUIPMENT and ME SYSTEMS intended for use in conjunction with flammable agents</b>		N/A

IEC 60601-1			
Clause	Requirement + Test	Result - Remark	Verdict
	<b>MANUFACTURER'S RISK MANAGEMENT PROCESS addresses possibility of fire and associated mitigations as confirmed by examination of RISK MANAGEMENT FILE .....</b> :	See Appended RM Results Table 11.5	N/A
<b>11.6</b>	<b>Overflow, spillage, leakage, ingress of water or particulate matter, cleaning, disinfection, sterilization and compatibility with substances used with the ME EQUIPMENT</b>		Pass
<b>11.6.1</b>	<b>Sufficient degree of protection provided against overflow, spillage, leakage, ingress of water or particulate matter, cleaning, disinfection and sterilization, and compatibility with substances used with ME EQUIPMENT.....</b> :	See Appended Table 11.6.1	Pass
<b>11.6.2</b>	<b>Overflow in ME EQUIPMENT</b>		N/A
	<b>Liquid reservoir liable to overflow in NORMAL USE completely filled and 15 % of its capacity poured in for over 1 min, and except when restricted, TRANSPORTABLE ME EQUIPMENT tilted through an angle of 15° in least favourable direction(s), and when necessary refilled starting from position of NORMAL USE.....</b> :	See Appended RM Results Table 11.6.2 and Table 11.6	N/A
	<b>ME EQUIPMENT met dielectric strength and LEAKAGE CURRENT tests and uninsulated electrical parts or electrical insulation of parts that could result in a HAZARDOUS SITUATION were not wet.....</b> :	See appended Table 8.7 and 8.8.3	N/A
<b>11.6.3</b>	<b>Spillage on ME EQUIPMENT and ME SYSTEM</b>		Pass
	<b>ME EQUIPMENT and ME SYSTEMS handling liquids in NORMAL USE positioned as in 5.4 a) and liquid with composition, volume, duration of spill, point of contact, and test conditions based on RISK MANAGEMENT PROCESS poured steadily on a point on top of ME EQUIPMENT .....</b> :	See Appended RM Results Table 11.6.3 and Table 11.6	Pass
	<b>ME EQUIPMENT met dielectric strength and LEAKAGE CURRENT tests and uninsulated electrical parts or electrical insulation of parts that could result in a HAZARDOUS SITUATION were not wet .....</b> :	See appended Tables 8.7 and 8.8.3	Pass
<b>11.6.4</b>	<b>Leakage</b>	See 13.2.6	N/A
<b>11.6.5</b>	<b>Ingress of water or particulate matter into ME EQUIPMENT and ME SYSTEMS</b>		N/A
	<b>ME EQUIPMENT with IP Code placed in least favourable position of NORMAL USE and subjected to tests of IEC 60529 (IP Code).....</b> :	See Appended RM Results Table 11.6.5 and Table 11.6	N/A

IEC 60601-1			
Clause	Requirement + Test	Result - Remark	Verdict
	<b>ME EQUIPMENT met dielectric strength and LEAKAGE CURRENT tests and there were no bridging of insulation or electrical components that could result in a HAZARDOUS SITUATION in NORMAL CONDITION or in a SINGLE FAULT CONDITION</b>	See appended Tables 8.7 8.8.3	N/A
<b>11.6.6</b>	<b>Cleaning and disinfection of ME EQUIPMENT and ME SYSTEMS</b>		Pass
	<b>ME EQUIPMENT/ME SYSTEM and their parts and ACCESSORIES cleaned or disinfected once using methods specified in instructions for use including any cooling or drying period ..... :</b>	See Appended RM Results Table 11.6.6 and Table 11.6 Evaluated according to method of cleaning mentioned in instructions for use	Pass
	<b>ME EQUIPMENT met dielectric strength and LEAKAGE CURRENT tests, with no deterioration resulting in an unacceptable RISK present ..... :</b>	See appended Tables 8.7 8.8.3	Pass
	<b>Effects of multiple cleanings/disinfections during EXPECTED SERVICE LIFE of EQUIPMENT evaluated by MANUFACTURER and assurance that no unacceptable RISK will occur verified by RISK MANAGEMENT FILE review..... :</b>	See RM Results Table 11.6.6 Evaluated according to method of cleaning mentioned in instructions for use	Pass
<b>11.6.7</b>	<b>Sterilization of ME EQUIPMENT and ME SYSTEMS</b>		N/A
	<b>ME EQUIPMENT, ME SYSTEMS and their parts or ACCESSORIES intended to be sterilized assessed and documented according to ISO 11134, ISO 11135, or ISO 11137 as appropriate..... :</b>	See Appended RM Results Table 11.6.7	N/A
	<b>After the test, ME EQUIPMENT complied with the appropriate dielectric strength and LEAKAGE CURRENT tests and there was no deterioration resulting in an unacceptable RISK..... :</b>	See appended Tables 8.7 8.8.3, and 11.6	N/A
<b>11.6.8</b>	<b>RISKS associated with compatibility of substances used with ME EQUIPMENT addressed in RISK MANAGEMENT PROCESS as confirmed by examination of RISK MANAGEMENT FILE..... :</b>	See Appended RM Results Table 11.6.8	N/A
<b>11.7</b>	<b>ME EQUIPMENT, ME SYSTEM, and ACCESSORIES coming into direct or indirect contact with biological tissues, cells, or body fluids assessed and documented per ISO 10993</b>	See Risk Management File	N/A
<b>11.8</b>	<b>Interruption and restoration of power supply did not result in a HAZARDOUS SITUATION, except interruption of its intended function</b>	Interruption does not result in hazardous situation	Pass
<b>12</b>	<b>ACCURACY OF CONTROLS AND INSTRUMENTS AND PROTECTION AGAINST HAZARDOUS OUTPUTS</b>		Pass
<b>12.1</b>	<b>RISKS associated with accuracy of controls and instruments stated in RISK MANAGEMENT PROCESS confirmed by RISK MANAGEMENT FILE review ..... :</b>	See Appended RM Results Table 12.1	Pass



IEC 60601-1			
Clause	Requirement + Test	Result - Remark	Verdict
12.2	RISK of poor USABILITY, including identification, marking, and documents addressed in a USABILITY ENGINEERING PROCESS as confirmed by review of provided records..... :	See Report based on IEC 60601-1-6	N/E
12.3	The need for alarm systems as a means of RISK CONTROL and RISKS associated with operation or failure of alarm system addressed in RISK MANAGEMENT PROCESS .....	See appended RM Results Table 12.3	Pass
12.4	Protection against hazardous output		Pass
12.4.1	RISKS associated with hazardous output arising from intentional exceeding of safety limits addressed in RISK MANAGEMENT PROCESS as confirmed in RISK MANAGEMENT FILE .....	See Appended RM Results Table 12.4.1	Pass
12.4.2	When applicable, need for indication of parameters associated with hazardous output addressed in RISK MANAGEMENT PROCESS as confirmed in RISK MANAGEMENT FILE .....	See Appended RM Results Table 12.4.2	Pass
12.4.3	RISKS associated with accidental selection of excessive output values for ME EQUIPMENT with a multi-purpose unit designed to provide low and high-intensity outputs for different treatments addressed in RISK MANAGEMENT PROCESS, confirmed in RISK MANAGEMENT FILE .. :	See Appended RM Results Table 12.4.3	Pass
12.4.4	When applicable, RISKS associated with incorrect output addressed in RISK MANAGEMENT PROCESS as confirmed by review of RISK MANAGEMENT FILE .....	See Appended RM Results Table 12.4.4	Pass
12.4.5	Diagnostic or therapeutic radiation		N/A
12.4.5.1	Adequate provisions to protect OPERATORS, PATIENTS, other persons and sensitive devices in vicinity of unwanted or excessive radiation emitted by ME EQUIPMENT designed to produce radiation for diagnostic/therapeutic purposes	Not intended for this application	N/A
	Radiation safety ensured by compliance with requirements of appropriate standards	Not intended for this application	N/A
12.4.5.2	RISKS associated with diagnostic X-rays addressed in RISK MANAGEMENT PROCESS as confirmed in RISK MANAGEMENT FILE .....	See IEC 60601-1-3 Report and appended RM Results Table 12.4.5.2	N/A
12.4.5.3	RISKS associated with radiotherapy addressed in RISK MANAGEMENT PROCESS as confirmed by review of RISK MANAGEMENT FILE .....	See Appended RM Results Table 12.4.5.3	N/A
12.4.5.4	RISKS associated with ME EQUIPMENT producing diagnostic or therapeutic radiation other than diagnostic X-rays and radiotherapy addressed in RISK MANAGEMENT PROCESS as confirmed by examination of RISK MANAGEMENT FILE..... :	See Appended RM Results Table 12.4.5.4	N/A



IEC 60601-1			
Clause	Requirement + Test	Result - Remark	Verdict
12.4.6	When applicable, RISKS associated with diagnostic or therapeutic acoustic pressure addressed in RISK MANAGEMENT PROCESS as confirmed in RISK MANAGEMENT FILE .....	See Appended RM Results Table 12.4.6	N/A
13	<b>HAZARDOUS SITUATIONS AND FAULT CONDITIONS</b>		Pass
13.1	<b>Specific HAZARDOUS SITUATIONS</b>		Pass
13.1.1	None of HAZARDOUS SITUATIONS in 13.1.2-13.1.4, inclusive, occurred when SINGLE FAULT CONDITIONS applied, one at a time, as in 4.7 and 13.2	Complied	Pass
13.1.2	<b>Emissions, deformation of ENCLOSURE or exceeding maximum temperature</b>		Pass
	– Emission of flames, molten metal, poisonous or ignitable substance in hazardous quantities did not occur	No excessive temperature	Pass
	– Deformation of ENCLOSURE impairing compliance with 15.3.1 did not occur	No excessive temperature	Pass
	– Temperatures of APPLIED PARTS did not exceed allowable values in Table 24 when measured as in 11.1.3..... :	See appended Tables 11.1.1, 11.1.2.1, and 11.1.2.2	Pass
	– Temperatures of ME EQUIPMENT parts that are not APPLIED PARTS likely to be touched did not exceed values in Table 23 when measured and adjusted as in 11.1.3..... :	See appended Tables 11.1.1, 11.1.2.1, and 11.1.2.2	Pass
	–Allowable values for “other components and materials” in Table 22 times 1.5 minus 12.5 °C were not exceeded	See appended Tables 11.1.1, 11.1.2.1, and 11.1.2.2	Pass
	Limits for windings in Tables 26, 27, and 31 not exceeded	See appended Tables 11.1.1, 11.1.2.1, and 11.1.2.2	Pass
	Table 22 not exceeded in all other cases	See appended Tables 11.1.1, 11.1.2.1, and 11.1.2.2	Pass
	Temperatures measured according to 11.1.3	Unit was tested in its normal position, in still air with using thermocouple method	Pass
	<b>SINGLE FAULT CONDITIONS in 4.7, 8.1 b), 8.7.2, and 13.2.2 relative to emission of flames, molten metal, or ignitable substances, not applied to parts and components where:</b>		Pass
	– Supply circuit was unable to supply 15 W one minute after 15 W drawn from supply circuit, or	See appended Table 13.1.2	N/A
	– Parts and components completely contained within a fire ENCLOSURE complying with 11.3 as verified by review of design documentation	Complied	Pass



IEC 60601-1			
Clause	Requirement + Test	Result - Remark	Verdict
	After tests of this Clause, settings of THERMAL CUT-OUTS and OVER-CURRENT RELEASES did not change sufficiently to affect their safety function	No thermal cut-outs	N/A
13.1.3	– limits for LEAKAGE CURRENT in SINGLE FAULT CONDITION based on 8.7.3 did not exceed..... :	See appended Table 8.7	Pass
	– voltage limits for ACCESSIBLE PARTS including APPLIED PARTS in 8.4.2 did not exceed .....	See appended Table 8.7	Pass
13.1.4	ME EQUIPMENT complied with the requirements of 9.1 to 9.8 for specific MECHANICAL HAZARDS	Complied	Pass
13. 2	SINGLE FAULT CONDITIONS		Pass
13.2.1	During application of SINGLE FAULT CONDITIONS in 13.2.2 -13.2.13, inclusive, NORMAL CONDITIONS in 8.1 a) applied in least favourable combination :	See appended Table 13.2	Pass
13.2.2 – 13.2.12	ME EQUIPMENT complied with 13.2.2 -13.2.12..... :	See appended Table 13.2 and RM Results Table 13.2.6	Pass
13.2.13	ME EQUIPMENT remained safe after tests of 13.2.13.2 to 13.2.13.4 (inclusive), and cooling down to room temperature	Inspected, unit remained safe	Pass
	ME EQUIPMENT examined for compliance or appropriate tests such as dielectric strength of motor insulation according to 8.8.3 conducted	Complied	Pass
	For insulation of thermoplastic materials relied upon as a MEANS OF PROTECTION (see 8.8), the ball-pressure test specified in 8.8.4.1 a) performed at a temperature 25 °C higher than temperature of insulation measured during tests of 13.2.13.2 to 13.2.13.4 (inclusive).	No such material	N/A
13.2.13.2	ME EQUIPMENT with heating elements		N/A
	a 1) thermostatically controlled ME EQUIPMENT with heating elements for building-in, or for unattended operation, or with a capacitor not protected by a fuse connected in parallel with THERMOSTAT contacts met tests of 13.2.13.2 b) & 13.2.13.2 c)	No heating elements	N/A
	a 2) ME EQUIPMENT with heating elements RATED for non-CONTINUOUS OPERATION met tests of 13.2.13.2 b) and 13.2.13.2 c)	No heating elements	N/A
	a 3) other ME EQUIPMENT with heating elements met test of 13.2.13.2 b)	No heating elements	N/A
	When more than one test was applicable to same ME EQUIPMENT, tests performed consecutively	No heating elements	N/A

IEC 60601-1			
Clause	Requirement + Test	Result - Remark	Verdict
	Heating period stopped when a heating element or an intentionally weak part of a non-SELF-RESETTING THERMAL CUT-OUT ruptured, or current interrupted before THERMAL STABILITY without possibility of automatic restoration	No heating elements	N/A
	Test repeated on a second sample when interruption was due to rupture of a heating element or an intentionally weak part	No heating elements	N/A
	Both samples met 13.1.2, and open circuiting of a heating element or an intentionally weak part in second sample not considered a failure by itself	No heating elements	N/A
	b) ME EQUIPMENT with heating elements tested per 11.1 without adequate heat discharge, and supply voltage set at 90 or 110 % of RATED supply voltage, least favourable of the two (V) : .....	No heating elements	N/A
	Operating period stopped when a non-SELF-RESETTING THERMAL CUT-OUT operated, or current interrupted without possibility of automatic restoration before THERMAL STABILITY	No heating elements	N/A
	ME EQUIPMENT switched off as soon as THERMAL STABILITY established and allowed to cool to room temperature when current not interrupted	No heating elements	N/A
	Test duration was equal to RATED operating time for non-CONTINUOUS OPERATION	No heating elements	N/A
	c) Heating parts of ME EQUIPMENT tested with ME EQUIPMENT operated in NORMAL CONDITION at 110 % of RATED supply voltage and as in 11.1, and	No heating elements	N/A
	1) Controls limiting temperature in NORMAL CONDITION disabled, except THERMAL CUT-OUTS	No heating elements	N/A
	2) When more than one control provided, they were disabled in turn	No heating elements	N/A
	3) ME EQUIPMENT operated at RATED DUTY CYCLE until THERMAL STABILITY achieved, regardless of RATED operating time	No heating elements	N/A
13.2.13.3	ME EQUIPMENT with motors		N/A
	a 1) For the motor part of the ME EQUIPMENT, compliance checked by tests of 13.2.8- 13.2.10, 13.2.13.3 b), 13.2.13.3 c), and 13.2.13.4, as applicable	No motors	N/A
	To determine compliance with 13.2.9 and 13.2.10 motors in circuits running at 42.4 V peak a.c./ 60 V d.c. or less are covered with a single layer of cheesecloth which did not ignite during the test	As above	N/A



IEC 60601-1			
Clause	Requirement + Test	Result - Remark	Verdict
	a 2) Tests on ME EQUIPMENT containing heating parts conducted at prescribed voltage with motor & heating parts operated simultaneously to produce the least favourable condition	As above	N/A
	a 3) Tests performed consecutively when more tests were applicable to the same ME EQUIPMENT	As above	N/A
	b) Motor met running overload protection test of this clause when:	As above	N/A
	1) it is intended to be remotely or automatically controlled by a single control device with no redundant protection, or	As above	N/A
	2) it is likely to be subjected to CONTINUOUS OPERATION while unattended	As above	N/A
	Motor winding temperature determined during each steady period and maximum value did not exceed Table 27 (Insulation Class, Maximum temperature measured °C)..... :	As above	N/A
	Motor removed from ME EQUIPMENT and tested separately when load could not be changed in appropriate steps	As above	N/A
	Running overload test for motors operating at 42.4 V peak a.c./60 V d.c. or less performed only when examination and review of design indicated possibility of an overload	As above	N/A
	Test not conducted where electronic drive circuits maintained a substantially constant drive current	As above	N/A
	Test not conducted based on other justifications (justification)..... :	As above	N/A
	c) ME EQUIPMENT with 3-phase motors operated with normal load, connected to a 3-phase SUPPLY MAINS with one phase disconnected, and periods of operation per 13.2.10	Single phase	N/A
13.2.13.4	ME EQUIPMENT RATED for NON-CONTINUOUS OPERATION		N/A
	ME EQUIPMENT (other than HAND-HELD) operated under normal load and at RATED voltage or at upper limit of RATED voltage range until increase in temperature was ≤ 5 °C in one hour, or a protective device operated	Continuous operation	N/A
	When a load-reducing device operated in NORMAL USE, test continued with ME EQUIPMENT running idle	Continuous operation	N/A
	Motor winding temperatures did not exceed values in 13.2.10 .....	Continuous operation	N/A



IEC 60601-1			
Clause	Requirement + Test	Result - Remark	Verdict
	<b>Insulation Class</b> .....	Continuous operation	—
	<b>Maximum temperature measured (°C)</b> .....	Continuous operation	—

<b>14</b>	<b>PROGRAMMABLE ELECTRICAL MEDICAL SYSTEMS (PEMS)</b>		Pass
<b>14.1</b>	<b>Requirements of this clause not applied to PESS when it provided no BASIC SAFETY or ESSENTIAL PERFORMANCE, OR</b>	See Risk Management File	Pass
	<b>- when application of ISO 14971 showed that failure of PESS does not lead to unacceptable RISK</b> .....	See Appended RM Results Table 14.1	Pass
	<b>Every PROCESS has been followed throughout the PEMS DEVELOPMENT LIFE-CYCLE and a RECORD of PROCESS has been made available as confirmed by RISK MANAGEMENT FILE REVIEW and assessment of PROCESSES cited in this Clause</b>	See Risk Management File	Pass
	<b>MANUFACTURER considered the need for additional RISK CONTROL measures when unable to follow all PROCESSES identified in Clause 14 for each constituent component of PEMS as confirmed by RISK MANAGEMENT FILE review and assessment of PROCESSES cited in this Clause</b>	See Risk Management File	Pass
	<b>Assessment of PROCESSES cited in this Clause made by internal audits</b>	See Risk Management File	Pass
<b>14.2</b>	<b>Documents produced from application of Clause 14 are maintained and form a part of RISK MANAGEMENT FILE in addition to RECORDS and documents required by ISO 14971</b> .....	See Risk Management File	Pass
<b>14.3</b>	<b>RISK MANAGEMENT plan required by 3.5 of ISO 14971 includes reference to PEMS VALIDATION plan</b>	See Risk Management File	Pass
<b>14.4</b>	<b>A PEMS DEVELOPMENT LIFE-CYCLE including a set of defined milestones has been documented</b>	See Risk Management File	Pass
	<b>At each milestone, activities to be completed, and VERIFICATION methods to be applied to activities have been defined</b>	See Risk Management File	Pass
	<b>Each activity including its inputs and outputs defined, and each milestone identifies RISK MANAGEMENT activities that must be completed before that milestone</b>	See Risk Management File	Pass
	<b>PEMS DEVELOPMENT LIFE-CYCLE tailored for a specific development by making plans detailing activities, milestones, and schedules</b>	See Risk Management File	Pass
	<b>PEMS DEVELOPMENT LIFE-CYCLE includes documentation requirements</b>	See Risk Management File	Pass

IEC 60601-1			
Clause	Requirement + Test	Result - Remark	Verdict
14.5	<b>A documented system for problem resolution within and between all phases and activities of PEMS DEVELOPMENT LIFE-CYCLE has been developed and maintained where appropriate</b>	See Risk Management File	Pass
	<b>Problem resolution system meets the prescribed criteria depending on type of product:</b>	See Risk Management File	Pass
	<b>– it is documented as a part of PEMS DEVELOPMENT LIFE-CYCLE</b>	See Risk Management File	Pass
	<b>– it allows reporting of potential or existing problems affecting BASIC SAFETY or ESSENTIAL PERFORMANCE</b>	See Risk Management File	Pass
	<b>– it includes an assessment of each problem for associated RISKS</b>	See Risk Management File	Pass
	<b>– it identifies criteria that must be met for the issue to be closed</b>	See Risk Management File	Pass
	<b>– it identifies the action to be taken to resolve each problem</b>	See Risk Management File	Pass
14.6	<b>RISK MANAGEMENT PROCESS</b>		Pass
14.6.1	<b>MANUFACTURER considered HAZARDS associated with software and hardware aspects of PEMS including NETWORK/DATA COUPLING, components of third-party origin, legacy subsystems when compiling list of known or foreseeable HAZARDS</b>	See Appended RM Results Table 14.6.1	Pass
	<b>In addition to the material in ISO 14971, Annex D, list of possible sources for HAZARDS associated with PEMS includes specified causes</b>	See Appended RM Results Table 14.6.1	Pass
	<b>– failure of NETWORK/DATA COUPLING to provide characteristics necessary for PEMS to achieve its BASIC SAFETY or ESSENTIAL PERFORMANCE</b>	See Appended RM Results Table 14.6.1	Pass
	<b>– undesired feedback [physical and data] (such as unsolicited/ out of range/ inconsistent input or input from electromagnetic interference)</b>	See Appended RM Results Table 14.6.1	Pass
	<b>– unavailable data</b>	See Appended RM Results Table 14.6.1	Pass
	<b>– lack of integrity of data</b>	See Appended RM Results Table 14.6.1	Pass
	<b>– incorrect data</b>	See Appended RM Results Table 14.6.1	Pass
	<b>– incorrect timing of data</b>	See Appended RM Results Table 14.6.1	Pass
	<b>– unintended interactions within &amp; among PESS</b>	See Appended RM Results Table 14.6.1	Pass
	<b>– unknown aspects or quality of third-party software</b>	See Appended RM Results Table 14.6.1	Pass



IEC 60601-1			
Clause	Requirement + Test	Result - Remark	Verdict
	– unknown aspects or quality of third-party PESS	See Appended RM Results Table 14.6.1	Pass
	– lack of data security, particularly vulnerability to tampering, unintended interaction with other programs and viruses	See Appended RM Results Table 14.6.1	Pass
14.6.2	Suitably validated tools and PROCEDURES assuring each RISK CONTROL measure reduces identified RISK(s) satisfactorily provided in addition to PEMS requirements in Clause 6.1 of ISO 14971 .....	See Appended RM Results Table 14.6.2	Pass
14.7	A documented requirement specification for PEMS and each of its subsystems (e.g. for a PESS) which includes ESSENTIAL PERFORMANCE and RISK CONTROL measures implemented by that system or subsystem .....	See Appended RM Results Table 14.7	Pass
14.8	An architecture satisfying the requirement is specified for PEMS and each of subsystems .....	See Appended RM Results Table 14.8	Pass
	The architecture specification makes use of considers the specified items to reduce RISK to an acceptable level, where appropriate:	See Appended RM Results Table 14.8	Pass
	a) COMPONENTS WITH HIGH-INTEGRITY CHARACTERISTICS	See Appended RM Results Table 14.8	Pass
	b) fail-safe functions	See Appended RM Results Table 14.8	Pass
	c) redundancy	See Appended RM Results Table 14.8	Pass
	d) diversity;	See Appended RM Results Table 14.8	Pass
	e) partitioning of functionality	See Appended RM Results Table 14.8	Pass
	f) defensive design potentially limiting hazardous effects by restricting available output power or by introducing means to limit travel of actuators	See Appended RM Results Table 14.8	Pass
	g) allocation of RISK CONTROL measures to subsystems and components of PEMS	See Appended RM Results Table 14.8	Pass
	h) failure modes of components and their effects;	See Appended RM Results Table 14.8	Pass
	i) common cause failures	See Appended RM Results Table 14.8	Pass
	j) systematic failures	See Appended RM Results Table 14.8	Pass
	k) test interval duration and diagnostic coverage	See Appended RM Results Table 14.8	Pass
	l) maintainability	See Appended RM Results Table 14.8	Pass

IEC 60601-1			
Clause	Requirement + Test	Result - Remark	Verdict
	m) protection from reasonably foreseeable misuse	See Appended RM Results Table 14.8	Pass
	n) NETWORK/DATA COUPLING specification, when applicable	See Appended RM Results Table 14.8	Pass
14.9	Design is broken up into subsystems, each with a design and test specification where appropriate, and descriptive data on design environment included in RISK MANAGEMENT FILE :	See Appended RM Results Table 14.9	Pass
14.10	A VERIFICATION plan containing the specified information used to verify and document functions implementing BASIC SAFETY, ESSENTIAL PERFORMANCE, OR RISK CONTROL measures ..... :	See Appended RM Results Table 14.10	Pass
	– milestone(s) when VERIFICATION is to be performed for each function	See Appended RM Results Table 14.10	Pass
	– selection and documentation of VERIFICATION strategies, activities, techniques, and appropriate level of independence of the personnel performing the VERIFICATION	See Appended RM Results Table 14.10	Pass
	– selection and utilization of VERIFICATION tools	See Appended RM Results Table 14.10	Pass
	– coverage criteria for VERIFICATION	See Appended RM Results Table 14.10	Pass
14.11	A PEMS VALIDATION plan containing validation of BASIC SAFETY & ESSENTIAL PERFORMANCE and requiring checks for unintended functioning of PEMS to perform and document PEMS VALIDATION	See Appended RM Results Table 14.11	Pass
	The person with overall responsibility for PEMS VALIDATION is independent of design team, and no member of a design team is responsible for PEMS VALIDATION of their own design	See Appended RM Results Table 14.11	Pass
	All professional relationships of members of PEMS VALIDATION team with members of design team documented in RISK MANAGEMENT FILE providing methods & results of PEMS VALIDATION	See Appended RM Results Table 14.11	Pass
14.12	Continued validity of previous design documentation assessed under a documented modification/change PROCEDURE	See Risk Management File	Pass
14.13	Technical description includes the following information when PEMS is to be connected to other equipment outside control of PEMS MANUFACTURER by NETWORK/DATA COUPLING ..... :	See Appended RM Results Table 14.13	Pass
	a) characteristics of NETWORK/DATA COUPLING necessary for PEMS to achieve its INTENDED USE	See Appended RM Results Table 14.13	Pass
	b) list of HAZARDOUS SITUATIONS resulting from a failure of NETWORK/DATA COUPLING to provide the specified characteristics	See Appended RM Results Table 14.13	Pass

IEC 60601-1			
Clause	Requirement + Test	Result - Remark	Verdict
	<b>c) instructions to RESPONSIBLE ORGANIZATION containing required information and warnings</b>	See Appended RM Results Table 14.13	Pass
	<b>– connection of PEMS to a NETWORK/DATA COUPLING that includes other equipment could result in previously unidentified RISKS and RESPONSIBLE ORGANIZATION shall identify, analyze, and control such RISKS</b>	See Appended RM Results Table 14.13	Pass
	<b>– subsequent changes to NETWORK/DATA COUPLING introducing new RISKS and requiring new analysis; and changes to NETWORK/DATA COUPLING include:</b>	See Appended RM Results Table 14.13	Pass
	<b>– NETWORK/DATA COUPLING configuration change</b>	See Appended RM Results Table 14.13	Pass
	<b>– connection of additional items to NETWORK/DATA COUPLING</b>	See Appended RM Results Table 14.13	Pass
	<b>– disconnecting items from NETWORK/DATA COUPLING</b>	See Appended RM Results Table 14.13	Pass
	<b>– update of equipment connected to NETWORK/DATA COUPLING</b>	See Appended RM Results Table 14.13	Pass
	<b>– upgrade of equipment connected to NETWORK/DATA COUPLING</b>	See Appended RM Results Table 14.13	Pass
<b>15</b>	<b>CONSTRUCTION OF ME EQUIPMENT</b>		Pass
<b>15.1</b>	<b>RISKS associated with arrangement of controls and indicators of ME EQUIPMENT addressed in RISK MANAGEMENT PROCESS, as confirmed by examination of RISK MANAGEMENT FILE ..... :</b>	See Appended RM Results Table 15.1	Pass
<b>15.2</b>	<b>Parts of ME EQUIPMENT subject to mechanical wear, electrical, environmental degradation or ageing resulting in unacceptable RISK when unchecked for a long period, are accessible for inspection, replacement, and maintenance</b>	Instructions provided in user manual	Pass
	<b>Inspection, servicing, replacement, and adjustment of parts of ME EQUIPMENT can easily be done without damage to or interference with adjacent parts or wiring</b>	As above	Pass
<b>15.3</b>	<b>Mechanical strength</b>		Pass
<b>15.3.1</b>	<b>Mold stress relief, push, impact, drop, and rough handling tests did not result in unacceptable RISK and ME EQUIPMENT displayed adequate mechanical strength</b>	Complied	Pass
<b>15.3.2</b>	<b>Push test conducted by subjecting external parts of ENCLOSURE to a steady force of 250 N ± 10 N for 5 s applied to a circular (30mm) plane surface, except bottom of ENCLOSURE of an ME EQUIPMENT &gt;18 kg, using a suitable test tool ... :</b>	See Appended Table 15.3 and RM Results Table 15.3.2	Pass

IEC 60601-1			
Clause	Requirement + Test	Result - Remark	Verdict
	No damage resulting in an unacceptable RISK sustained as determined by examination of RISK MANAGEMENT FILE	Complied	Pass
15.3.3	Impact test conducted by subjecting a complete ENCLOSURE or its largest non-reinforced area, except for HAND-HELD ME EQUIPMENT and parts, to a free falling 500 g ± 25 g solid smooth steel ball, approx. 50 mm in diameter from a height of 1.3 m .....	See Appended Table 15.3 and RM Results Table 15.3.3	Pass
	Test not applied to flat panel displays, platen glass of ME EQUIPMENT, or cathode ray tubes	Complied	Pass
	No damage resulting in an unacceptable RISK sustained as shown in RISK MANAGEMENT FILE	As above	Pass
15.3.4	Drop test		Pass
15.3.4.1	Sample of HAND-HELD ME EQUIPMENT and HAND-HELD part with SAFE WORKING LOAD allowed to fall freely once from each of 3 different positions as in NORMAL USE from height specified in ACCOMPANYING DOCUMENTS, or from 1 m onto a 50 mm ± 5 mm thick hardwood board lying flat on a concrete or rigid base.....	See Appended Table 15.3	N/A
	No unacceptable RISK resulted	Not Hand-held	N/A
15.3.4.2	Sample of PORTABLE ME EQUIPMENT and PORTABLE part with SAFE WORKING LOAD lifted to a height as in Table 29 above a 50 ± 5 mm thick hardwood board lying flat on a concrete floor or rigid base, dropped 3 times from each orientation in NORMAL USE (cm) .....	See Appended Table 15.3 and RM Table 15.3.4.2	Pass
	No damage resulting in an unacceptable RISK sustained as determined by examination of sample and RISK MANAGEMENT FILE	Tested with acceptable results	Pass
15.3.5	Each sample of MOBILE ME EQUIPMENT and MOBILE part with SAFE WORKING LOAD and in most adverse condition in NORMAL USE passed Rough Handling tests .....	See Appended Table 15.3 and RM Results Table 15.3.5	N/A
	a) Ascending step shock test conducted on the sample by pushing it 3 times in its normal direction of travel at 0.4 m/s ± 0.1 m/s against an ascending hardwood step obstruction without the sample going over the obstruction	Not mobile	N/A
	b) Descending step shock test conducted on the sample by pushing it 3 times in its normal direction of travel at 0.4 m/s ± 0.1 m/s in order to fall over a vertical step affixed flat on a rigid base with direction of movement perpendicular to face of the step until full descent achieved	As above	N/A

IEC 60601-1			
Clause	Requirement + Test	Result - Remark	Verdict
	<b>c) Door frame shock test conducted on the sample by moving it 3 times in its normal direction of travel at 0.4 m/s ± 0.1 m/s, or for motor driven EQUIPMENT, at maximum possible speed against a hardwood vertical obstacle higher than EQUIPMENT contact point(s)</b>	As above	N/A
	<b>No damage resulting in an unacceptable RISK sustained as determined by examination of sample and RISK MANAGEMENT FILE</b>	As above	N/A
15.3.6	<b>Examination of ENCLOSURE made from molded or formed thermoplastic material indicated that material distortion due to release of internal stresses by molding or forming operations will not result in an unacceptable RISK</b>	No such materials	N/A
	<b>Mold-stress relief test conducted by placing one sample of complete ME EQUIPMENT, ENCLOSURE or a portion of larger ENCLOSURE, for 7 hours in a circulating air oven at 10°C over the max temperature measured on ENCLOSURE in 11.1.3, but no less than 70 °C .....</b>	Not required	N/A
	<b>No damage resulting in an unacceptable RISK</b>	As above	N/A
15.3.7	<b>INTENDED USE, EXPECTED SERVICE LIFE, and conditions for transport and storage were taken into consideration for selection and treatment of materials used in construction of ME EQUIPMENT</b>	Unit, accompanied documents and manufacturer's specifications inspected	Pass
	<b>Based on review of EQUIPMENT, ACCOMPANYING DOCUMENTS, specifications and processing of materials, and MANUFACTURER'S relevant tests or calculations, corrosion, ageing, mechanical wear, degradation of biological materials due to bacteria, plants, animals and the like, will not result in an unacceptable RISK</b>	Unit, accompanied documents and manufacturer's specifications inspected	Pass
15.4	<b>ME EQUIPMENT components and general assembly</b>		Pass
15.4.1	<b>Incorrect connection of accessible connectors, removable without a TOOL, prevented where an unacceptable RISK exists, in particular .....</b>	See Appended RM Results Table 15.4.1	Pass
	<b>a) Plugs for connection of PATIENT leads cannot be connected to other outlets on same ME EQUIPMENT intended for other functions, except when RISK MANAGEMENT FILE provides proof that no unacceptable RISK could result .....</b>	See attachment #	N/A
	<b>b) Medical gas connections on ME EQUIPMENT for different gases to be operated in NORMAL USE are not interchangeable as verified by review of RISK MANAGEMENT FILE .....</b>	See attachment #	N/A
15.4.2	<b>Temperature and overload control devices</b>		N/A

IEC 60601-1			
Clause	Requirement + Test	Result - Remark	Verdict
15.4.2.1	a) THERMAL CUT-OUTS and OVER-CURRENT RELEASES with automatic resetting not used in ME EQUIPMENT when their use could result in a HAZARDOUS SITUATION by resetting action as verified by review of RISK MANAGEMENT FILE ..... :	See Appended RM Results Table 15.4.2.1 a)	N/A
	b) THERMAL CUT-OUTS with a safety function to be reset by a soldering operation affecting operating value not fitted in ME EQUIPMENT as verified by examination of design and RISK MANAGEMENT FILE..... :	See Appended RM Results Table 15.4.2.1 b)	N/A
	c) An independent non-SELF-RESETTING THERMAL CUT-OUT is, additionally, provided where a failure of a THERMOSTAT could constitute a HAZARD as verified by examination of design and RISK MANAGEMENT FILE..... :	See Appended RM Results Table 15.4.2.1 c)	N/A
	d) Based on design and RISK MANAGEMENT FILE review, loss of function of ME EQUIPMENT due to operation of THERMAL CUT-OUT or OVER CURRENT RELEASE doesn't result in a HAZARDOUS SITUATION	See Appended RM Results Table 15.4.2.1 d)	N/A
	e) Capacitors or other spark-suppression devices not connected between contacts of THERMAL CUT-OUTS	No such parts	N/A
	f) Use of THERMAL CUT-OUTS or OVER-CURRENT RELEASES do not affect safety of ME EQUIPMENT as verified by following tests:		N/A
	Positive temperature coefficient devices (PTC's) complied with IEC 60730-1: 1999, clauses 15, 17, J.15, and J.17 as applicable	No such parts	N/A
	ME EQUIPMENT containing THERMAL CUT-OUTS and OVER-CURRENT RELEASES operated under the conditions of Clause 13 .....	See appended Table 13.2	N/A
	SELF-RESETTING THERMAL CUT-OUTS and OVER-CURRENT RELEASES including circuits performing equivalent functions (other than PTC's) Certified according to appropriate standards ..	No such parts	N/A
	In the absence of Certification in accordance with IEC standards, SELF-RESETTING THERMAL CUT-OUTS and OVER-CURRENT RELEASES including circuits performing equivalent functions (other than PTC's) operated 200 times	As above	N/A
	Manual reset THERMAL CUT-OUTS and OVER-CURRENT RELEASES Certified in accordance with appropriate IEC standards	As above	N/A

IEC 60601-1			
Clause	Requirement + Test	Result - Remark	Verdict
	When certification based on IEC standards, or data from MANUFACTURER demonstrating reliability of component to perform its safety-related function is not available, manual reset THERMAL CUT-OUTS and OVER-CURRENT RELEASES operated 10 times	As above	N/A
	Thermal protective devices tested separately from ME EQUIPMENT when engineering judgment indicated test results would not be impacted	Not necessary	N/A
	g) Protective device, provided on ME EQUIPMENT incorporating a fluid filled container with heating means, operated when heater switched on with container empty and prevented an unacceptable RISK due to overheating	No such parts	N/A
	h) ME EQUIPMENT with tubular heating elements provided with protection against overheating in both leads where a conductive connection to earth could result in overheating as verified by review of design and RISK MANAGEMENT FILE ..... :	See Appended RM Results Table 15.4.2.1 h) No such parts	N/A
15.4.2.2	Temperature settings clearly indicated when means provided to vary setting of THERMOSTATS	No thermostats	N/A
15.4.3	Batteries		Pass
15.4.3.1	Battery housings from which gases can escape during charging or discharging likely to result in a HAZARD ventilated to minimize RISK of accumulation and ignition as verified by review of design and RISK MANAGEMENT FILE..... :	See Appended RM Results Table 15.4.3.1	Pass
	Battery compartments prevent accidental short circuiting of battery when this could result in a HAZARDOUS SITUATION as verified by examination of design and RISK MANAGEMENT FILE		Pass
15.4.3.2	Means provided to prevent incorrect connection of polarity when a HAZARDOUS SITUATION may develop by incorrect connection or replacement of a battery ..... :	See Appended RM Results Table 15.4.3.2	Pass
15.4.3.3	Overcharging of battery prevented by virtue of design when it could result in an unacceptable RISK as verified by review of design ..... :	See Appended RM Results Table 15.4.3.3	Pass
15.4.3.4	Lithium batteries that could become a HAZARD complied with appropriate tests of IEC 60086-4	See Appended RM Results Table 15.4.3.4	Pass
	Tests of IEC 60086-4 waived on the lithium battery based on examination of design		Pass

IEC 60601-1			
Clause	Requirement + Test	Result - Remark	Verdict
15.4.3.5	A properly RATED protective device provided within INTERNAL ELECTRICAL POWER SOURCE to protect against fire caused by excessive currents when (in case of a short circuit) layout of internal wiring, cross-sectional area, rating of connected components can result in a fire :	See Appended RM Results Table 15.4.3.5	Pass
	Protective device has adequate breaking capacity to interrupt the maximum fault current		Pass
	Justification for OVER-CURRENT RELEASES or FUSE exclusion is included in RISK MANAGEMENT FILE		Pass
15.4.4	Indicator lights provided to indicate ME EQUIPMENT is ready for NORMAL USE, except when apparent to OPERATOR from normal operating position, and marking of 7.4.1 are insufficient for this purpose .....	See Appended RM Results Table 15.4.4 Green light	Pass
	An additional indicator light provided on ME EQUIPMENT with a stand-by state or a warm-up state exceeding 15 s, except when apparent to OPERATOR from normal operating position	Not relevant	N/A
	Indicator lights provided on ME EQUIPMENT incorporating non-luminous heaters to indicate heaters are operational when a HAZARDOUS SITUATION could exist, except when apparent to OPERATOR from normal operating position	No such heaters	N/A
	Requirement not applied to heated stylus-pens for recording purposes	Not relevant	N/A
	Indicator lights provided on ME EQUIPMENT to indicate an output exists where an accidental or prolonged operation of output circuit could constitute a HAZARDOUS SITUATION	No such indicator	N/A
	Colours of indicator lights complied with 7.8.1	Complied	Pass
	Charging mode visibly indicated in ME EQUIPMENT incorporating a means for charging an INTERNAL ELECTRICAL POWER SOURCE		Pass
15.4.5	RISKS associated with pre-set controls addressed in RISK MANAGEMENT PROCESS when applicable as verified by review of RISK MANAGEMENT FILE .....	See Appended RM Results Table 15.4.5 No such controls	N/A
15.4.6	Actuating parts of controls of ME EQUIPMENT		Pass
15.4.6.1	a) Actuating parts cannot be pulled off or loosened up during NORMAL USE	Complied	Pass
	b) Indication of scales (e.g., "on" "off" positions, etc.) always corresponds to position of controls with adjustment that can result in a HAZARDOUS SITUATION for PATIENT or OPERATOR while ME EQUIPMENT is in use	As above	Pass

IEC 60601-1			
Clause	Requirement + Test	Result - Remark	Verdict
	<b>c) Incorrect connection of indicating device to relevant component prevented by adequate construction when it could be separated without use of a TOOL</b>	As above	Pass
	<b>When torque values per Table 30 applied between control knob and shaft of rotating controls for not less than 2 s, 10 times in each direction, knobs did not rotate .....</b> :	See appended Table 15.4.6	N/A
	<b>Tests conducted by applying an axial force of 60 N for electrical components and 100 N for other components for 1 min when an axial pull was required in NORMAL USE with no unacceptable RISK .....</b> :	See appended Table 15.4.6	N/A
15.4.6.2	<b>Stops of adequate mechanical strength provided on rotating/ movable parts of controls of ME EQUIPMENT where necessary to prevent an unexpected change from max to min, or vice-versa, of the controlled parameter when this could cause a HAZARDOUS SITUATION .....</b> :	See appended Table 15.4.6	N/A
	<b>Torque values in Table 30 applied 10 times in each direction to rotating controls for 2 sec ...</b> :	See appended Table 15.4.6	N/A
	<b>Application of an axial force of 60 N for electrical components and 100 N for other components to rotating or movable parts of controls for 1 min when an axial pull was required in NORMAL USE .....</b> :	See appended Table 15.4.6	N/A
15.4.7	<b>Cord-connected HAND-HELD and foot-operated control devices</b>		N/A
15.4.7.1	<b>a) HAND-HELD control devices of ME EQUIPMENT complied with 15.3.4.1</b>	No such control devices	N/A
	<b>b) Foot-operated control device supported an actuating force of 1350 N for 1 min applied over an area of 30 mm diameter in its position of NORMAL USE with no damage to device causing an unacceptable RISK.....</b> :		N/A
15.4.7.2	<b>Control device of HAND-HELD and foot-operated control devices turned in all possible abnormal positions and placed on a flat surface .....</b> :		N/A
	<b>No unacceptable RISK caused by changing control setting when accidentally placed in an abnormal position</b>		N/A
15.4.7.3	<b>a) Foot-operated control device is at least IPX1 &amp; complies with tests of IEC 60529 (IP Code) ..</b> :	See appended Table 11.6 IP Code = __IPX7__	N/A
	<b>b) ENCLOSURE of foot operated control devices containing electrical circuits is at least IPX6 and complies with IEC 60529 if in NORMAL USE liquids are likely to be found (IP Code) .....</b> :	See appended Table 11.6 and RM Results Table 15.4.7.3 b) IP Code = __IPX7__	N/A

IEC 60601-1			
Clause	Requirement + Test	Result - Remark	Verdict
	Probability of occurrence estimated as part of RISK MANAGEMENT PROCESS	Complied	N/A
15.4.8	Aluminium wires less than 16 mm <sup>2</sup> in cross-sectional area are not used	No Aluminium wires	N/A
15.4.9	a) Oil container in PORTABLE ME EQUIPMENT allows for expansion of oil and is adequately sealed to prevent loss of oil in any position	No Oil containers	N/A
	b) Oil containers in MOBILE ME EQUIPMENT sealed to prevent loss of oil during transport	No Oil containers	N/A
	A pressure-release device operating during NORMAL USE is, optionally, provided	No Oil containers	N/A
	c) Partially sealed oil-filled ME EQUIPMENT and its parts provided with means for checking the oil level to detect leakage	No Oil containers	N/A
	ME EQUIPMENT and technical description examined, and manual tests conducted to confirm compliance with above requirements	No Oil containers	N/A
15.5	MAINS SUPPLY TRANSFORMERS OF ME EQUIPMENT and transformers providing separation in accordance with 8.5		Pass
	Mains supply transformers of me equipment is part of Approved Medical Power supply		Pass
15.5.1	Overheating		Pass
15.5.1.1	Transformers of ME EQUIPMENT are protected against overheating in the event of short circuit or overload of output windings and comply with this Clause and tests of 15.5.1.2 – 3 .....	See appended Tables 15.5.1.2 and 15.5.1.3 Approved isolation transformer is a part of approved power supply	Pass
	During tests, windings did not open, no HAZARDOUS SITUATION occurred, and maximum temperatures of windings did not exceed values in Table 31	Complied	Pass
	Dielectric strength test of 8.8.3 conducted on transformer after short circuit and overload tests .....	See appended Table 15.5.2	N/A
15.5.1.2	Transformer output winding short circuited, and test continued until protective device operated or THERMAL STABILITY achieved .....	See appended Table 15.5.1.2	N/A
	Short circuit applied directly across output windings for transformers not tested according to 5X frequency and 5X voltage test of 15.5.2		N/A
15.5.1.3	Multiple overload tests conducted on windings with more than one protective device to evaluate worst-case NORMAL USE loading and protection .....	See appended Table 15.5.1.3	N/A

IEC 60601-1			
Clause	Requirement + Test	Result - Remark	Verdict
15.5.2	Transformer windings provided with adequate insulation to prevent internal short-circuits that could cause overheating which could result in a HAZARDOUS SITUATION	Inspected	Pass
	Dielectric strength tests were conducted in accordance with requirements of this clause with no breakdown of insulation system and no detectable deterioration of transformer .....	See appended Table 15.5.2	N/A
15.5.3	Transformers forming MEANS OF PROTECTION as required by 8.5 comply with IEC 61558-1:1997, Clause 5.12 .....	See appended Table 8.10	Pass

16	<b>ME SYSTEMS</b>		N/A
16.1	After installation or subsequent modification, ME SYSTEM didn't result in an unacceptable RISK	See Appended RM Results Table 16.1	N/A
	Only HAZARDS arising from combining various equipment to form a ME SYSTEM considered		N/A
	– ME SYSTEM provides the level of safety within the PATIENT ENVIRONMENT equivalent to ME EQUIPMENT complying with this standard	EUT is not considered as system	N/A
	– ME SYSTEM provides the level of safety outside PATIENT ENVIRONMENT equivalent to equipment complying with their respective IEC or ISO safety standards	As above	N/A
	– tests performed in NORMAL CONDITION, except as specified	As above	N/A
	– tests performed under operating conditions specified by MANUFACTURER of ME SYSTEM	As above	N/A
	Safety tests previously conducted on individual equipment of ME SYSTEM according to relevant standards not repeated	As above	N/A
	RISK MANAGEMENT methods, optionally, used by MANUFACTURER of an ME SYSTEM reconfigurable by RESPONSIBLE ORGANIZATION or OPERATOR to determine configurations with highest RISKS and measures to ensure any configuration of ME SYSTEM will not present unacceptable RISKS	As above	N/A
	Non-ME EQUIPMENT used in ME SYSTEM complied with applicable IEC or ISO safety standards	As above	N/A
	Equipment relying only on BASIC INSULATION for protection against electric shock not used in ME SYSTEM	2 MOPP protection provided	N/A
16.2	<b>ACCOMPANYING DOCUMENTS of an ME SYSTEM</b>		N/A

IEC 60601-1			
Clause	Requirement + Test	Result - Remark	Verdict
	<b>Documents containing all data necessary for ME SYSTEM to be used as intended by MANUFACTURER including a contact address accompany ME SYSTEM or modified ME SYSTEM</b>	Provided	N/A
	<b>ACCOMPANYING DOCUMENTS regarded as a part of ME SYSTEM</b>	As above	N/A
	<b>ACCOMPANYING DOCUMENTS are, optionally, provided in electronic format (e.g. electronic file format or CD ROM) and ME SYSTEM is capable of displaying or printing these documents</b>	No electronic format documents provided	N/A
	<b>a) ACCOMPANYING DOCUMENTS provided for each item of ME EQUIPMENT supplied by MANUFACTURER</b>	Provided	N/A
	<b>b) ACCOMPANYING DOCUMENTS provided for each item of non-ME EQUIPMENT supplied by MANUFACTURER</b>	As above	N/A
	<b>c) the required information is provided:</b>		N/A
	<b>– specifications, instructions for use as intended by MANUFACTURER, and a list of all items forming the ME SYSTEM</b>	Provided	N/A
	<b>– instructions for installation, assembly, and modification of ME SYSTEM to ensure continued compliance with this standard</b>	As above	N/A
	<b>– instructions for cleaning and, when applicable, disinfecting and sterilizing each item of equipment or equipment part forming part of the ME SYSTEM</b>	As above	N/A
	<b>– additional safety measures to be applied during installation of ME SYSTEM</b>	As above	N/A
	<b>– identification of parts of ME SYSTEM suitable for use within the PATIENT ENVIRONMENT</b>	As above	N/A
	<b>– additional measures to be applied during preventive maintenance</b>	Not specified	N/A
	<b>– a warning forbidding placement of MULTIPLE SOCKET-OUTLET, when provided and it is a separate item, on the floor</b>	As above	N/A
	<b>– a warning indicating an additional MULTIPLE SOCKET-OUTLET or extension cord not to be connected to ME SYSTEM</b>	As above	N/A
	<b>– a warning to connect only items that have been specified as part of ME SYSTEM or specified as being compatible with ME SYSTEM</b>	Provided	N/A
	<b>– maximum permissible load for any MULTIPLE SOCKET-OUTLET(S) used with ME SYSTEM</b>	Not specified	N/A



IEC 60601-1			
Clause	Requirement + Test	Result - Remark	Verdict
	– instructions indicating <b>MULTIPLE SOCKET-OUTLETS</b> provided with the ME SYSTEM to be used only for supplying power to equipment intended to form part of ME SYSTEM	As above	N/A
	– an explanation indicating <b>RISKS</b> of connecting <b>non-ME EQUIPMENT</b> supplied as a part of ME SYSTEM directly to wall outlet when non-ME EQUIPMENT is intended to be supplied via a <b>MULTIPLE SOCKET-OUTLET</b> with a separating transformer	As above	N/A
	– an explanation indicating <b>RISKS</b> of connecting any equipment supplied as a part of ME SYSTEM to <b>MULTIPLE SOCKET-OUTLET</b>	As above	N/A
	– permissible environmental conditions of use for ME SYSTEM including conditions for transport and storage	Provided	N/A
	– instructions to OPERATOR not to, simultaneously, touch parts referred to in 16.4 and PATIENT	As above	N/A
	<b>d) the following instructions provided for use by RESPONSIBLE ORGANIZATION:</b>		N/A
	– adjustment, cleaning, sterilization, and disinfection PROCEDURES	Provided	N/A
	– assembly of ME SYSTEMS and modifications during actual service life shall be evaluated based on the requirements of this standard	Not specified	N/A
16.3	Instructions for use of ME EQUIPMENT intended to receive its power from other equipment in an ME SYSTEM, describe the other equipment to ensure compliance with these requirements	As above	N/A
16.4	Parts of non-ME EQUIPMENT in PATIENT ENVIRONMENT subject to contact by OPERATOR during maintenance, calibration, after removal of covers, connectors, etc., without use of a TOOL operated at a voltage $\leq$ voltage in 8.4.2 c) supplied from a source separated from SUPPLY MAINS by two MEANS OF OPERATOR PROTECTION	No such parts	N/A
16.5	Safety measures incorporating a SEPARATION DEVICE applied when FUNCTIONAL CONNECTION between ME EQUIPMENT and other items of an ME SYSTEM or other systems can cause allowable values of LEAKAGE CURRENT to exceed	Not specified	N/A
	SEPARATION DEVICE has dielectric strength, CREEPAGE and CLEARANCES required for one MEANS OF OPERATOR PROTECTION appropriate for highest voltage occurring across SEPARATION DEVICE during a fault condition	As above	N/A

IEC 60601-1			
Clause	Requirement + Test	Result - Remark	Verdict
	<b>WORKING VOLTAGE was highest voltage across SEPARATION DEVICE during a fault condition, but not less than MAXIMUM MAINS VOLTAGE (V)..... :</b>	As above	N/A
<b>16.6</b>	<b>LEAKAGE CURRENTS</b>		N/A
<b>16.6.1</b>	<b>TOUCH CURRENT in NORMAL CONDITION, from or between parts of ME SYSTEM within the PATIENT ENVIRONMENT, did not exceed 100 µA .....</b> :	See appended Table 16.6.1	N/A
	<b>TOUCH CURRENT did not exceed 500 µA in event of interruption of any non-PERMANENTLY INSTALLED PROTECTIVE EARTH CONDUCTOR, from or between parts of ME SYSTEM within PATIENT ENVIRONMENT .....</b> :	See appended Table 16.6.1	N/A
<b>16.6.2</b>	<b>Current in PROTECTIVE EARTH CONDUCTOR of MULTIPLE SOCKET-OUTLET did not exceed 5 mA.. :</b>	Tested with acceptable results	N/A
<b>16.6.3</b>	<b>PATIENT LEAKAGE CURRENT and total PATIENT LEAKAGE CURRENT of ME SYSTEM in NORMAL CONDITION did not exceed values specified for ME EQUIPMENT in Tables 3 and 4 .....</b> :	See appended Tables 8.7 8.7.4.7 and 16.6.1	N/A
	<b>Measurements made using a device as in clause 8.7.4.4</b>	Complied	N/A
<b>16.7</b>	<b>ME SYSTEM complied with applicable requirements of Clause 9 when a MECHANICAL HAZARD existed .....</b> :	See applicable appended Tables in section 9	N/A
<b>16.8</b>	<b>Interruption and restoration of relevant power connections of ME SYSTEM one at a time and all connections simultaneously did not result in a HAZARDOUS SITUATION other than interruption of its intended function</b>	Inspected	N/A
<b>16.9</b>	<b>ME SYSTEM connections and wiring</b>		N/A
<b>16.9.1</b>	<b>Incorrect connection of accessible connectors, removable without a TOOL, prevented where a HAZARDOUS SITUATION could otherwise exist .....</b> :	See Appended RM Results Table 16.9.1	N/A
	<b>– Connectors complied with Clause 15.4.1</b>	Complied	N/A
	<b>– Plugs for connection of PATIENT leads could not be connected to other outlets of the same ME SYSTEM likely to be located in PATIENT ENVIRONMENT, except when examination of connectors and interchanging them proved no HAZARDOUS SITUATION could result</b>	Appropriate markings are used to determine each connection of patient leads	N/A
<b>16.9.2</b>	<b>MAINS PARTS, components and layout</b>		N/A
<b>16.9.2.1</b>	<b>a) – MULTIPLE SOCKET-OUTLET only allows connection using a TOOL, or</b>	No multiple socket-outlet	N/A



IEC 60601-1			
Clause	Requirement + Test	Result - Remark	Verdict
	– MULTIPLE SOCKET-OUTLET is of a type that cannot accept MAINS PLUGS of any of the kinds specified in IEC/TR 60083, or	As above	N/A
	– MULTIPLE SOCKET-OUTLET is supplied via a separating transformer	As above	N/A
	b) – MULTIPLE SOCKET-OUTLET marked with safety sign 2 of Table D.2 (i.e., safety sign ISO 7010-W001) visible in NORMAL USE, and	As above	N/A
	– marked either individually or in combinations, with the maximum allowed continuous output in amperes or volt-amperes, or	As above	N/A
	– marked to indicate the equipment or equipment parts it may safely be attached to	As above	N/A
	– MULTIPLE SOCKET-OUTLET is a separate item or an integral part of ME EQUIPMENT or non-ME EQUIPMENT	As above	N/A
	c) MULTIPLE SOCKET-OUTLET complied with IEC 60884-1 and the following requirements:	As above	N/A
	– CREEPAGE and CLEARANCES complied with 8.9	As above	N/A
	– It is CLASS I, and PROTECTIVE EARTH CONDUCTOR is connected to earthing contacts in socket-outlets	As above	N/A
	– PROTECTIVE EARTH TERMINALS and PROTECTIVE EARTH CONNECTIONS comply with 8.6, except total impedance for ME SYSTEM was up to 400 mΩ, or higher when conditions of 8.6.4 b) met (mΩ).. :	As above	N/A
	– ENCLOSURE complied with 8.4.2 d)	As above	N/A
	– MAINS TERMINAL DEVICES and wiring complied with 8.11.4, when applicable	As above	N/A
	– RATINGS of components are not in conflict with conditions of use .....	See appended Table 8.10	N/A
	– Electrical terminals and connectors of MULTIPLE SOCKET-OUTLETS prevent incorrect connection of accessible connectors removable without a TOOL	As above	N/A
	– POWER SUPPLY CORD complied with 8.11.3	As above	N/A
	d) Additional requirements applied when MULTIPLE SOCKET-OUTLET combined with a separating transformer:	As above	N/A
	– Separating transformer complied with IEC 61558-2-1, except requirements of maximum RATED output power of 1 kVA and degree of protection IPX4 were not applied .....	See appended Table 8.10	N/A

IEC 60601-1			
Clause	Requirement + Test	Result - Remark	Verdict
	– Separating transformer is CLASS I	As above	N/A
	– Degree of protection against ingress of water specified as in IEC 60529	As above	N/A
	– Separating transformer assembly marked according to 7.2 and 7.3	As above	N/A
	– MULTIPLE SOCKET-OUTLET permanently connected to separating transformer, or socket-outlet of separating transformer assembly cannot accept MAINS PLUGS as identified in IEC/TR 60083	As above	N/A
16.9.2.2	Removal of any single item of equipment in ME SYSTEM will not interrupt the protective earthing of any other part without simultaneous disconnection of electrical supply to that part	Inspected	N/A
	Additional PROTECTIVE EARTH CONDUCTORS can be detachable only by use of a TOOL	No additional protective earth conductors	N/A
16.9.2.3	Conductors connecting different items within an ME SYSTEM protected against mechanical damage	Complied	N/A

17	<b>ELECTROMAGNETIC COMPATIBILITY OF ME EQUIPMENT AND ME SYSTEMS</b>		Pass
	RISKS associated with items addressed in RISK MANAGEMENT PROCESS as confirmed by review . :	See Appended RM Results Table 17	Pass
	– electromagnetic phenomena at locations where ME EQUIPMENT or ME SYSTEM is to be used as stated in ACCOMPANYING DOCUMENTS .....	See ITL report according to IEC60601-1-2	Pass
	– introduction of electromagnetic phenomena into environment by ME EQUIPMENT or ME SYSTEM that might degrade performance of other devices, electrical equipment, and systems	See ITL report according to IEC60601-1-2	Pass

ANNEX G	<b>PROTECTION AGAINST HAZARDS OF IGNITION OF FLAMMABLE ANESTHETIC MIXTURES</b>		N/A
G.2	Locations and basic requirements		N/A
G.2.1	Parts of CATEGORY APG ME EQUIPMENT in which a FLAMMABLE ANESTHETIC MIXTURE WITH AIR occurs are CATEGORY AP or APG ME EQUIPMENT and complied with G.3, G.4, and G.5		N/A
G.2.2	FLAMMABLE AESTHETIC MIXTURE WITH AIR occurring due to a leakage or discharge of a FLAMMABLE AESTHETIC MIXTURE WITH OXYGEN or NITROUS OXIDE from an ENCLOSURE considered 5 to 25 cm from point of occurrence		N/A



IEC 60601-1			
Clause	Requirement + Test	Result - Remark	Verdict
G.2.3	A FLAMMABLE AESTHETIC MIXTURE WITH OXYGEN OR NITROUS OXIDE contained in a completely / partly enclosed ME EQUIPMENT part and in PATIENT'S respiratory tract 5 cm from an ENCLOSURE part where leakage or discharge occurs		N/A
G.2.4	ME EQUIPMENT or parts thereof specified for use with FLAMMABLE AESTHETIC MIXTURE WITH AIR (in a location as in G.2.2) are CATEGORY AP or APG ME EQUIPMENT and complied with G.4 and G.5		N/A
G.2.5	ME EQUIPMENT or parts thereof for use with FLAMMABLE AESTHETIC MIXTURE WITH OXYGEN OR NITROUS OXIDE (location per G.2.2) are CATEGORY APG ME EQUIPMENT and comply with G.4 and G.6		N/A
	ME EQUIPMENT in G.2.3 to G.2.5 met appropriate tests of G.3-G.5 conducted after tests of 11.6.6 and 11.6.7		N/A
G.3	Marking, ACCOMPANYING DOCUMENTS		N/A
G.3.1	CATEGORY APG ME EQUIPMENT prominently marked. with a green-coloured band $\geq 2$ cm wide with letters "APG" according to symbol 23 in Table D.1..... :	See copies of Marking Labels	N/A
	Length of green-coloured band is $\geq 4$ cm, and size of marking is as large as possible for particular case		N/A
	When above marking not possible, relevant information included in instructions for use ... :		N/A
	Marking complied with tests and criteria of 7.1.2 and 7.1.3		N/A
G.3.2	CATEGORY AP ME EQUIPMENT prominently marked, with a green-coloured circle $\geq 2$ cm in diameter, with characters "AP" according to symbol 22 in Table D.1..... :	See copies of Marking Labels	N/A
	Marking is as large as possible for the particular case		N/A
	When above marking not possible, the relevant information included in instructions for use ... :		N/A
	Marking complied with tests and criteria of 7.1.2 and 7.1.3		N/A
G.3.3	The marking according to G.3.2 and G.3.3 placed on major part of ME EQUIPMENT for CATEGORY AP or APG parts, and not repeated on detachable parts that can only be used with the marked EQUIPMENT		N/A



IEC 60601-1			
Clause	Requirement + Test	Result - Remark	Verdict
G.3.4	ACCOMPANYING DOCUMENTS contain an indication enabling the RESPONSIBLE ORGANIZATION to distinguish between CATEGORY AP and APG parts		N/A
G.3.5	Marking clearly indicates which parts are CATEGORY AP or APG when only certain ME EQUIPMENT parts are CATEGORY AP or APG		N/A
G.4	Common requirements for CATEGORY AP and CATEGORY APG ME EQUIPMENT		N/A
G.4.1	a) CREEPAGE and CLEARANCES between points of POWER SUPPLY CORD connection are according to Table 12 for one MEANS OF PATIENT PROTECTION		N/A
	b) Connections, except those in circuits described in G.5.3 and G.6.3, protected against accidental disconnection in NORMAL USE or connection and disconnection can be performed only with a TOOL		N/A
	c) CATEGORY AP and APG not provided with a DETACHABLE POWER SUPPLY CORD, except when circuit complied with G.5.3 and G.6.3		N/A
G.4.2	Construction details		N/A
	a) Opening of an ENCLOSURE providing protection against penetration of gases or vapours into ME EQUIPMENT or its parts possible only with a TOOL		N/A
	b) ENCLOSURE complies with requirements to minimize arcing and sparking due to penetration of foreign objects .....	See appended Table 8.10	N/A
	– no openings on top covers of ENCLOSURE, except for openings for controls covered by control knobs		N/A
	– openings in side-covers prevented penetration of a solid cylindrical test rod of 4 mm in diameter applied in all possible directions without appreciable force		N/A
	– openings in base plates prevented penetration of a solid cylindrical test rod of 12 mm in diameter applied in all directions without appreciable force		N/A
	c) Short circuiting conductor(s) to a conductive part without presence of explosive gasses where insulation may contact a part containing a FLAMMABLE AESTHETIC MIXTURE WITH OXYGEN or NITROUS OXIDE, ignitable gases alone, or oxygen, did not result in loss of integrity of the part, an unacceptable temperature, or other HAZARD		N/A

IEC 60601-1			
Clause	Requirement + Test	Result - Remark	Verdict
G.4.3	a) Electrostatic charges prevented on CATEGORY AP and APG ME EQUIPMENT by a combination of appropriate measures		N/A
	– Use of antistatic materials with a limited electrical resistance as specified in G.4.3 b) ... :	See appended Table 8.10	N/A
	– Provision of electrically conductive paths from ME EQUIPMENT or its parts to a conductive floor, protective earth or potential equalization system, or via wheels to an antistatic floor of medical room		N/A
	b) Electrical resistance limits of aesthetic tubing, mattresses and pads, castor tires, and other antistatic material complied with ISO 2882 based on measurements according to ISO 1853, ISO 2878 and ISO 23529 ..... :		N/A
G.4.4	Corona cannot be produced by components or parts of ME EQUIPMENT operating at more than 2000 V a.c. or 2400 V d.c. and not included in ENCLOSURES complying with G.5.4 or G.5.5		N/A
G.5	Requirements and tests for CATEGORY AP ME EQUIPMENT, parts and components		N/A
G.5.1	ME EQUIPMENT, its parts or components do not ignite FLAMMABLE AESTHETIC MIXTURES WITH AIR under NORMAL USE and CONDITIONS based on compliance with G.5.2 to G.5.5 (inclusive)		N/A
	Alternatively, ME EQUIPMENT, its parts, and components complied with requirements of IEC 60079-0 for pressurized ENCLOSURES (IEC 60079-2); for sand-filled ENCLOSURES, IEC 60079-5; or for oil immersed equipment, IEC 60079-6; and with this standard excluding G.5.2 to G.5.5..... :		N/A
G.5.2	ME EQUIPMENT, its parts, and components in contact with gas mixtures in NORMAL USE and CONDITIONS not producing sparks and not resulting in surface temperatures above 150 °C in case of restricted or 200 °C in case of unrestricted vertical air circulation measured at 25 °C comply with G.5.1 ..... :	See appended Tables 11.1.1, 11.1.2.1, 11.1.2.2, & 11.2.2.1	N/A
G.5.3	ME EQUIPMENT, its parts, and components producing sparks in NORMAL USE and CONDITION complied with temperature requirements of G.5.2, and $U_{max}$ and $I_{max}$ occurring in their circuits, and complied as follows:		N/A
	Measured $U_{max} \leq U_{zR}$ with $I_{zR}$ as in Fig. G.1..... :	$U_{max} = \text{---} V$ $U_{zR} = \text{---} V$ $I_{zR} = \text{---} A$	N/A

IEC 60601-1			
Clause	Requirement + Test	Result - Remark	Verdict
	Measured $U_{max} \leq U_c$ with $C_{max}$ as in Fig. G.2 ... :	$U_{max} = \text{___} V$ $U_c = \text{___} V$ $C_{max} = \text{___} \mu F$	N/A
	Measured $I_{max} \leq I_{zR}$ with $U_{zR}$ as in Fig G.1 .....	$I_{max} = \text{___} A$ $I_{zR} = \text{___} A$ $U_{zR} = \text{___} V$	N/A
	Measured $I_{max} \leq I_{zL}$ with $L_{max}$ and a $U_{max} \leq 24 V$ as in Fig G.3 .....	$I_{max} = \text{___} A$ $I_{zL} = \text{___} A$ $L_{max} = \text{___} mH$	N/A
	– Combinations of currents and corresponding voltages within the limitations $I_{zR} \cdot U_{zR} \leq 50 W$ extrapolated from Fig G.1		N/A
	No extrapolation made for voltages above 42 V		N/A
	– Combinations of capacitances and corresponding voltages within limitations of $C/2U^2 \leq 1.2 mJ$ extrapolated from Fig G.2		N/A
	No extrapolation made for voltages above 242V		N/A
	$U_{max}$ , additionally, determined using actual resistance R when the equivalent resistance R was less than 8000 $\Omega$		N/A
	– Combinations of currents and corresponding inductances within limitations $L/2I^2 \leq 0.3 mJ$ extrapolated from Fig G.3		N/A
	No extrapolation made for inductances larger than 900 mH		N/A
	– $U_{max}$ was the highest supply voltage occurring in circuit under investigation with sparking contact open, taking into consideration MAINS VOLTAGE variations in 4.10		N/A
	– $I_{max}$ was the highest current flowing in circuit under investigation with sparking contact closed, taking into consideration MAINS VOLTAGE variations required in 4.10		N/A
	– $C_{max}$ and $L_{max}$ taken as values occurring at the component under investigation producing sparks		N/A
	– Peak value considered when a.c. supplied		N/A
	– An equivalent circuit calculated to determine equivalent max capacitance, inductance, and equivalent $U_{max}$ and $I_{max}$ , either as d.c. or a.c. peak values in case of a complicated circuit... :		N/A
	Temperature measurements made according to 11.1, and $U_{max}$ , $I_{max}$ , R, $L_{max}$ , and $C_{max}$ determined with application of Figs G.1-G.3 .. :	See appended Tables 11.1.1, 11.1.2.1, & 11.1.2.2	N/A



IEC 60601-1			
Clause	Requirement + Test	Result - Remark	Verdict
	Alternatively, compliance was verified by examination of design data .....		N/A
<b>G.5.4</b>	<b>External ventilation with internal overpressure</b>		N/A
	ME EQUIPMENT, its parts, and components enclosed in an ENCLOSURE with external ventilation by means of internal overpressure complied with the following requirements:		N/A
	a) FLAMMABLE AESTHETIC MIXTURES WITH AIR that might have penetrated into ENCLOSURE of ME EQUIPMENT or part removed by ventilation before EQUIPMENT energized, and penetration of such mixtures during operation was prevented by maintenance of overpressure by means of air without flammable gases, or by physiologically acceptable inert gas (e.g., nitrogen)		N/A
	b) Overpressure inside ENCLOSURE was 75 Pa, min., in NORMAL CONDITION (Pa)..... :		N/A
	Overpressure maintained at the site of potential ignition even when air or inert gas could escape through openings in ENCLOSURE necessary for normal operation of ME EQUIPMENT or its parts		N/A
	ME EQUIPMENT could be energized only after the required minimum overpressure was present long enough to ventilate the ENCLOSURE so that the displaced volume of air or inert gas was at least five times the volume of ENCLOSURE		N/A
	ME EQUIPMENT energized at will or repeatedly when overpressure was continuously present		N/A
	c) Ignition sources de-energized automatically by means used where G.4 does not apply, or complied with G.5 when during operation overpressure dropped below 50 Pa (Pa) .....		N/A
	d) External surface of ENCLOSURE in which internal overpressure was maintained did not exceed 150 °C in 25 °C ambient under NORMAL USE and CONDITION (°C) .....		N/A
<b>G.5.5</b>	<b>ENCLOSURES with restricted breathing</b>		N/A
	ME EQUIPMENT, its parts, and components enclosed in an ENCLOSURE with restricted breathing complied with the following:		N/A

IEC 60601-1			
Clause	Requirement + Test	Result - Remark	Verdict
	a) A FLAMMABLE AESTHETIC MIXTURE WITH AIR did not form inside ENCLOSURE with restricted breathing when it was surrounded by a FLAMMABLE AESTHETIC MIXTURE WITH AIR of a high concentration for at least 30 min without any pressure difference inside ENCLOSURE		N/A
	b) Gasket or sealing material used to maintain tightness complied with aging test B-b of IEC 60068-2-2, Clause 15, at 70 °C ± 2 °C and 96 h :	See appended Table 8.10	N/A
	c) Gas-tightness of ENCLOSURE containing inlets for flexible cords maintained when the cords were stressed by bending or pulling		N/A
	Cords are fitted with adequate anchorages to limit stresses		N/A
	After the test in G.5.4 b), an internal overpressure of 400 Pa was created and 30 pulls of the value in Table G.1 applied to each flexible cord in axial direction of cord inlet and in the least favourable direction for 1 s		N/A
	Overpressure not reduced below 200 Pa		N/A
	Tests waived when examination of ENCLOSURE indicated it is completely sealed or gas-tight without a doubt (100 % degree of certainty)		N/A
	Operating temperature of external surface of ENCLOSURE was ≤ 150 °C in 25 °C (°C) .....		N/A
	Steady state operating temperature of ENCLOSURE also measured (°C) .....		N/A
<b>G.6</b>	<b>CATEGORY APG ME EQUIPMENT, parts and components thereof</b>		
<b>G.6.1</b>	<b>ME EQUIPMENT, its parts, and components did not ignite FLAMMABLE AESTHETIC MIXTURE WITH OXYGEN OR NITROUS OXIDE under NORMAL USE and SINGLE FAULT CONDITION</b>		N/A
	<b>ME EQUIPMENT, its parts, and components not complying with G.6.3 subjected to a CONTINUOUS OPERATION test after attaining thermal steady state (max. 3 h) over a period of 10 min in a 12.2 % ± 0.4 ether by volume/oxygen mixture</b>		N/A
<b>G.6.2</b>	<b>Parts and components of CATEGORY APG ME EQUIPMENT operating in a FLAMMABLE AESTHETIC MIXTURE WITH OXYGEN OR NITROUS OXIDE supplied from a source isolated from earth by insulation equal to one MEANS OF PATIENT PROTECTION and from electrical parts by insulation twice the MEANS OF PATIENT PROTECTION..... :</b>		N/A

IEC 60601-1			
Clause	Requirement + Test	Result - Remark	Verdict
<b>G.6.3</b>	<b>Test of G.6.1 waived when the following requirements were met in NORMAL USE and under NORMAL and SINGLE FAULT CONDITIONS..... :</b>		N/A
	<b>a) no sparks produced and temperatures did not exceed 90 °C, or</b>	See Tables 11.1.1, 11.1.2.1, 11.1.2.2, 11.2.2.1, and 13.2	N/A
	<b>b) a temperature limit of 90 °C not exceeded, sparks produced in NORMAL USE, and SINGLE FAULT CONDITIONS, except <math>U_{max}</math> and <math>I_{max}</math> occurring in their circuits complied with requirements, taking <math>C_{max}</math> and <math>L_{max}</math> into consideration:</b>	See Tables 11.1.1, 11.1.2.1, 11.1.2.2, and 13.2	N/A
	<b>Measured <math>U_{max} \leq U_{zR}</math> with <math>I_{zR}</math> as in Fig. G.4 ..... :</b>	$U_{max} = \text{___} V$ $U_{zR} = \text{___} V$ $I_{zR} = \text{___} A$	N/A
	<b>Measured <math>U_{max} \leq U_{zC}</math> with <math>C_{max}</math> as in Fig. G.5... :</b>	$U_{max} = \text{___} V$ $U_c = \text{___} V$ $C_{max} = \text{___} \mu F$	N/A
	<b>Measured <math>I_{max} \leq I_{zR}</math> with <math>U_{zR}</math> as in Fig G.4 ..... :</b>	$I_{max} = \text{___} A$ $I_{zR} = \text{___} A$ $U_{zR} = \text{___} V$	N/A
	<b>Measured <math>I_{max} \leq I_{zL}</math> with <math>L_{max}</math> and a <math>U_{max} \leq 24 V</math> as in Fig G.6 ..... :</b>	$I_{max} = \text{___} A$ $I_{zL} = \text{___} A$ $L_{max} = \text{___} mH$	N/A
	<b>– Extrapolation from Figs G.4, G.5, and G.6 was limited to areas indicated</b>		N/A
	<b>– <math>U_{max}</math> was the highest no-load voltage occurring in the circuit under investigation, taking into consideration mains voltage variations as in 4.10</b>		N/A
	<b>– <math>I_{max}</math> was the highest current flowing in the circuit under investigation, taking into account MAINS VOLTAGE variations as in 4.10</b>		N/A
	<b>– <math>C_{max}</math> and <math>L_{max}</math> are values occurring in relevant circuit</b>		N/A
	<b>– <math>U_{max}</math> additionally determined with actual resistance R when equivalent resistance R in Fig G.5 was less than 8000 <math>\Omega</math></b>		N/A
	<b>– Peak value taken into consideration when a.c. supplied</b>		N/A
	<b>– An equivalent circuit calculated to determine max capacitance, inductance, and <math>U_{max}</math> and <math>I_{max}</math>, either as d.c. or a.c. peak values in case of a complicated circuit ..... :</b>		N/A

IEC 60601-1			
Clause	Requirement + Test	Result - Remark	Verdict
	– When energy produced in an inductance or capacitance in a circuit is limited by voltage or current-limiting devices, two independent components applied, to obtain the required limitation even when a first fault (short or open circuit) in one of these components		N/A
	Above requirement not applied to transformers complying with this standard		N/A
	Above requirement not applied to wire-wound current-limiting resistors provided with a protection against unwinding of the wire in case of rupture		N/A
	Compliance verified by examination of CATEGORY APG ME EQUIPMENT, parts, and components , or		N/A
	Temperature measurements made in accordance with 11.1, or	See Tables 11.1.1, 11.1.2.1, and 11.1.2.2	N/A
	$U_{max}$ , $I_{max}$ , R, $L_{max}$ and $C_{max}$ determined together with application of Figs G.4-G.6..... :	$U_{max} = \_\_\_V$ $I_{max} = \_\_\_A$ $R = \_\_\_\Omega$ $L_{max} = \_\_\_mH$ $C_{max} = \_\_\_\mu F$	N/A
	Alternatively, compliance verified by comparison with design data .....:		N/A
<b>G.6.4</b>	ME EQUIPMENT, its parts, and components heating a FLAMMABLE AESTHETIC MIXTURE WITH OXYGEN OR NITROUS OXIDE provided with a non-SELF-RESETTING THERMAL CUT-OUT and complied with 15.4.2.1..... :	See appended Table 8.10	N/A
	Current-carrying part of heating element is not in direct contact with FLAMMABLE AESTHETIC MIXTURE WITH OXYGEN OR NITROUS OXIDE		N/A
<b>G.7</b>	Test apparatus for flammable mixtures		N/A
	Test apparatus used was in accordance with this Clause and Fig G.7		N/A

<b>ANNEX L</b>	<b>INSULATED WINDING WIRES FOR USE WITHOUT INTERLEAVED INSULATION</b>		N/A
<b>L.1</b>	BASIC, SUPPLEMENTARY, DOUBLE, and REINFORCED INSULATION in wound components without interleaved insulation complied with this Annex covering round winding wires between 0.05 mm and 5.00 mm diameters		N/A
<b>L.2</b>	Wire construction		N/A

IEC 60601-1			
Clause	Requirement + Test	Result - Remark	Verdict
	Overlap of layers when wire is insulated with two or more spirally wrapped layers of tape is adequate to ensure continued overlap during manufacture of wound component		N/A
	Layers of spirally wrapped wire insulation are sufficiently secured to maintain the overlap		N/A
L.3	Type Test		N/A
	The wire subjected to tests of L.3.1 to L.3.4 at a temperature and a relative humidity specified		N/A
	Temperature (°C) .....		—
	Humidity (%) .....		—
L.3.1	Dielectric strength		N/A
	Dielectric strength test of Clause 8.8.3 for the appropriate type and number of MOP(s) conducted by preparing the sample according to IEC 60851-5:1996, Clause 4.4.1 for a twisted pair with test voltages at least twice Tables 6 & 7, but not less than below with no breakdown:		N/A
	– 3000 V for BASIC and SUPPLEMENTARY INSULATION (V) .....		N/A
	– 6000 V for REINFORCED INSULATION (V) .....		N/A
L.3.2	Flexibility and adherence		N/A
	Sample subjected to flexibility and adherence test 8 of IEC 60851-3:1996, clause 5.1.1, using mandrel diameters of Table L.1		N/A
	Sample examined according to IEC 60851-3: 1997, clause 5.1.1.4, followed by dielectric test of clause 8.8.3, except test voltage applied between wire and mandrel with no breakdown		N/A
	Test voltage was at least the voltage in Tables 6 and 7 but not less than the following:		N/A
	– 1500 V for BASIC and SUPPLEMENTARY INSULATION (V) .....		N/A
	– 3000 V for REINFORCED INSULATION (V) .....		N/A
	Tension applied to wire during winding on mandrel calculated from the wire diameter equivalent to 118 MPa ± 11.8 MPa .....		N/A
L.3.3	Heat Shock		N/A
	Sample subjected to heat shock test 9 of IEC 60851-6:1996, followed by dielectric strength test of clause 8.8.3, except test voltage applied between the wire and mandrel		N/A

IEC 60601-1			
Clause	Requirement + Test	Result - Remark	Verdict
	Test voltage was at least the voltage in Tables 6 and 7, but not less than the following:		N/A
	– 1500 V for BASIC and SUPPLEMENTARY INSULATION (V) .....		N/A
	– 3000 V for REINFORCED INSULATION (V).....		N/A
	Oven temperature based on Table L.2 (°C) .....		—
	Mandrel diameter and tension applied as in clause L.3.2, (MPa; N/mm <sup>2</sup> ).....		N/A
	Dielectric strength test conducted at room temperature after removal from the oven		N/A
<b>L.3.4</b>	<b>Retention of electric strength after bending</b>		N/A
	Five samples prepared as in L.3.2 subjected to dielectric strength and bending tests		N/A
	Test voltage was at least the voltage in Tables 6 and 7, but not less than the following:		N/A
	– 1500 V for BASIC and SUPPLEMENTARY INSULATION (V) .....		N/A
	– 3000 V for REINFORCED INSULATION (V).....		N/A
	Test voltage applied between the shot and conductor.		N/A
	Mandrel diameter and tension applied as in L.3.2, (MPa; N/mm <sup>2</sup> ).....		N/A
<b>L.4</b>	<b>Tests during manufacture</b>		N/A
<b>L.4.1</b>	<b>Production line dielectric strength tests conducted by the manufacture according to L.4.2 and L.4.3.....</b>	See attached manufacturer's routine testing verification	N/A
<b>L.4.2</b>	<b>Test voltage for routine testing (100 % testing) is at least the voltage in Tables 6 and 7 but not less than the following:</b>		N/A
	– 1500 V r.m.s. or 2100 V peak for BASIC and SUPPLEMENTARY INSULATION (V) .....	See manufacturer's routine testing verification	N/A
	– 3000 V r.m.s. or 4200 V peak for REINFORCED INSULATION (V) .....	See manufacturer's routine testing verification	N/A
<b>L.4.3</b>	<b>Sampling tests conducted using twisted pair samples (IEC 60851-5:1996, clause 4.4.1)</b>	See manufacturer's routine testing verification	N/A
	Minimum breakdown test voltage at least twice the voltage in Tables 6 and 7 but not less than:		N/A
	– 3000 V r.m.s. or 4200 V peak for BASIC and SUPPLEMENTARY INSULATION	See manufacturer's routine testing verification	N/A
	– 6000 V r.m.s. or 8400 V peak for REINFORCED INSULATION	See manufacturer's routine testing verification	N/A

IEC 60601-1			
Clause	Requirement + Test	Result - Remark	Verdict
4.2	RM RESULTS TABLE: Risk Management Process for ME Equipment or ME Systems		Pass
Clause of ISO 14971	Document Ref. in RMF (Document No. & paragraph)	Result - Remarks	Verdict
3.3a	F60-SY-RA-SY-01-REV.I		Pass
3.5e	F60-SY-RA-SY-01-REV.I		Pass
4.1	F60-SY-RA-SY-01-REV.I		Pass
4.2	F60-SY-RA-SY-01-REV.I		Pass
4.3	F60-SY-RA-SY-01-REV.I		Pass
4.4	F60-SY-RA-SY-01-REV.I		Pass
5	F60-SY-RA-SY-01-REV.I		Pass
6.1	F60-SY-RA-SY-01-REV.I		Pass
6.2	F60-SY-RA-SY-01-REV.I		Pass
6.3	F60-SY-RA-SY-01-REV.I		Pass
6.4	F60-SY-RA-SY-01-REV.I		Pass
6.5	F60-SY-RA-SY-01-REV.I		Pass
6.6	F60-SY-RA-SY-01-REV.I		Pass
6.7	F60-SY-RA-SY-01-REV.I		Pass
7	F60-SY-RA-SY-01-REV.I		Pass

4.3	TABLE: ESSENTIAL PERFORMANCE		N/A
List of ESSENTIAL PERFORMANCE functions	MANUFACTURER'S document number reference or reference from this standard or collateral or particular standard(s)	Remarks	
<b>Supplementary Information:</b>			
ESSENTIAL PERFORMANCE is performance, the absence or degradation of which, would result in an unacceptable risk.			

4.3	RM RESULTS TABLE: Essential Performance		N/A
Clause of ISO 14971	Document Ref. in RMF (Document No. & paragraph)	Result - Remarks	Verdict
4.2			
4.3			
4.4			
5			

IEC 60601-1			
Clause	Requirement + Test	Result - Remark	Verdict
4.5	<b>RM RESULTS TABLE: Equivalent Safety for ME Equipment of ME System</b>		N/A
Clause of ISO 14971	Document Ref. in RMF (Document No. & paragraph)	Result - Remarks	Verdict
4.2			
4.3			
4.4			
5			
6.2			
6.3			
6.4			
6.5			
4.6	<b>RM RESULTS TABLE: ME Equipment or system parts contacting the patient</b>		Pass
Clause of ISO 14971	Document Ref. in RMF (Document No. & paragraph)	Result - Remarks	Verdict
4.2	F60-SY-RA-SY-01-REV.I		Pass
4.3	F60-SY-RA-SY-01-REV.I		Pass
4.4	F60-SY-RA-SY-01-REV.I		Pass
5	F60-SY-RA-SY-01-REV.I		Pass
6.2	F60-SY-RA-SY-01-REV.I		Pass
6.3	F60-SY-RA-SY-01-REV.I		Pass
6.4	F60-SY-RA-SY-01-REV.I		Pass
6.5	F60-SY-RA-SY-01-REV.I		Pass
4.7	<b>RM RESULTS TABLE: Single Fault Condition for ME Equipment</b>		Pass
Clause of ISO 14971	Document Ref. in RMF (Document No. & paragraph)	Result - Remarks	Verdict
4.2	F60-SY-RA-SY-01-REV.I		Pass
4.3	F60-SY-RA-SY-01-REV.I		Pass
4.4	F60-SY-RA-SY-01-REV.I		Pass
4.8	<b>RM RESULTS TABLE: Components of ME Equipment</b>		Pass
Clause of ISO 14971	Document Ref. in RMF (Document No. & paragraph)	Result - Remarks	Verdict
4.2	F60-SY-RA-SY-01-REV.I		Pass
4.3	F60-SY-RA-SY-01-REV.I		Pass
4.4	F60-SY-RA-SY-01-REV.I		Pass
5	F60-SY-RA-SY-01-REV.I		Pass
6.2	F60-SY-RA-SY-01-REV.I		Pass
6.3	F60-SY-RA-SY-01-REV.I		Pass
6.4	F60-SY-RA-SY-01-REV.I		Pass



IEC 60601-1			
Clause	Requirement + Test	Result - Remark	Verdict
4.8	RM RESULTS TABLE: Components of ME Equipment		Pass
Clause of ISO 14971	Document Ref. in RMF (Document No. & paragraph)	Result - Remarks	Verdict
6.5	F60-SY-RA-SY-01-REV.I		Pass

4.9	RM RESULTS TABLE: Use of components with high-integrity characteristics		N/A
Clause of ISO 14971	Document Ref. in RMF (Document No. & paragraph)	Result - Remarks	Verdict
4.2			
4.3			
4.4			
5			
6.2			
6.3			
6.4			
6.5			

IEC 60601-1			
Clause	Requirement + Test	Result - Remark	Verdict

4.11	TABLE: Power Input					P
Operating Conditions / Ratings	Voltage (V)	Frequency (Hz)	Current (A)	Power (W)	Power factor (cos φ)	
Max. Normal Load	90	60	0.91	80.8	0.9	
Max. Normal Load	100	60	0.89	79.0	0.8	
Max. Normal Load	240	60	0.42	79.4	0.7	
Max. Normal Load	264	60	0.41	78.1	0.7	
Max. Normal Load	90	50	0.89	79.1	0.9	
Max. Normal Load	100	50	0.79	80.5	0.9	
Max. Normal Load	240	50	0.39	77.8	0.8	
Max. Normal Load	264	50	0.374	79.1	0.8	
Max. Normal Load	10.8	-	4.7	50.7	-	
Max. Normal Load	12	-	4.6	55.2	-	
Max. Normal Load	15	-	3.1	46.5	-	
Max. Normal Load	16.5	-	2.9	47.8	-	

**Supplementary Information:**

The measured input current did not exceed the rating 100-240V; 50/60 Hz; Max.1.25A; 12-15 Vdc, 4.8A  
**Note\*:** Test was conducted with empty batteries, so maximum power consumption was registered with battery recharging

5.1	RM RESULTS TABLE: Type Tests		Pass
Clause of ISO 14971	Document Ref. in RMF (Document No. & paragraph)	Result - Remarks	Verdict
4.2	F60-SY-RA-SY-01-REV.I		Pass
4.3	F60-SY-RA-SY-01-REV.I		Pass
4.4	F60-SY-RA-SY-01-REV.I		Pass

5.4 a)	RM RESULTS TABLE: Other Conditions		Pass
Clause of ISO 14971	Document Ref. in RMF (Document No. & paragraph)	Result - Remarks	Verdict
4.2	F60-SY-RA-SY-01-REV.I		Pass
4.3	F60-SY-RA-SY-01-REV.I		Pass
4.4	F60-SY-RA-SY-01-REV.I		Pass



IEC 60601-1			
Clause	Requirement + Test	Result - Remark	Verdict

5.7	RM RESULTS TABLE: Humidity preconditioning treatment		Pass
Clause of ISO 14971	Document Ref. in RMF (Document No. & paragraph)	Result - Remarks	Verdict
4.2	F60-SY-RA-SY-01-REV.I		Pass
4.3	F60-SY-RA-SY-01-REV.I		Pass
4.4	F60-SY-RA-SY-01-REV.I		Pass
5	F60-SY-RA-SY-01-REV.I		Pass
6.2	F60-SY-RA-SY-01-REV.I		Pass
6.3	F60-SY-RA-SY-01-REV.I		Pass
6.4	F60-SY-RA-SY-01-REV.I		Pass
6.5	F60-SY-RA-SY-01-REV.I		Pass

5.9.2	TABLE: Determination of ACCESSIBLE parts		Pass
Location	Determination method (NOTE1)	Comments	
Unit enclosure + Applied Part	visual	Only enclosure and AP accessible	

**Supplementary information:**

NOTE 1 - The determination methods are: visual; rigid test finger; jointed test finger; test hook.

5.9.2.3	RM RESULTS TABLE: Actuating mechanisms		N/A
Clause of ISO 14971	Document Ref. in RMF (Document No. & paragraph)	Result - Remarks	Verdict
4.2			
4.3			
4.4			
5			
6.2			
6.3			
6.4			
6.5			



IEC 60601-1			
Clause	Requirement + Test	Result - Remark	Verdict

7.1.2	TABLE: Legibility of Marking		P
Markings tested	Ambient illuminance (lx)	Remarks	
Outside Markings (Clause 7.2) .....	100 – 1500	Correctly visible	
Inside Markings (Clause 7.3) .....	100 – 1500	Correctly visible	
Controls & Instruments (Clause 7.4) .....	100 – 1500	Correctly visible	
Safety Signs (Clause 7.5) .....	100 – 1500	Correctly visible	
Symbols (Clause 7.6) .....	100 – 1500	Correctly visible	

**Supplementary information:**

Observer, with a visual acuity of 0 on the log Minimum Angle of Resolution (log MAR) scale or 6/6 (20/20), reads marking at ambient illuminance least favourable level in the range of 100 lx to 1,500 lx. The ME EQUIPMENT or its part was positioned so that the viewpoint was the intended position of the OPERATOR at any point within the base of a cone subtended by an angle of 30° to the axis normal to the centre of the plane of the marking and at a distance of 1 m.

7.1.3	TABLE: Durability of marking test		P
Characteristics of the Marking Label tested:		Remarks	
Material of Marking Label .....	Polymeric held by adhesive		
Ink/other printing material or process .....	Printed ink		
Material (composition) of Warning Label .....	Polymeric held by adhesive		
Ink/other printing material or process .....	Printed ink		
Other .....	---		

**Supplementary information:**

Marking rubbed by hand, first for 15 s with a cloth rag soaked with distilled water, then for 15 s with a cloth rag soaked with methylated spirit, and then for 15 s with a cloth rag soaked with isopropyl alcohol.

7.2.2	RM RESULTS TABLE: Identification		Pass
Clause of ISO 14971	Document Ref. in RMF (Document No. & paragraph)	Result - Remarks	Verdict
4.2	F60-SY-RA-SY-01-REV.I		Pass
4.3	F60-SY-RA-SY-01-REV.I		Pass
4.4	F60-SY-RA-SY-01-REV.I		Pass
5	F60-SY-RA-SY-01-REV.I		Pass
6.4	F60-SY-RA-SY-01-REV.I		Pass

IEC 60601-1			
Clause	Requirement + Test	Result - Remark	Verdict

7.2.5	RM RESULTS TABLE: ME EQUIPMENT powered from other equipment		N/A
Clause of ISO 14971	Document Ref. in RMF (Document No. & paragraph)	Result - Remarks	Verdict
4.2			
4.3			
4.4			
5			
6.4			

7.2.13	RM RESULTS TABLE: Physiological effects (safety signs and warning)		Pass
Clause of ISO 14971	Document Ref. in RMF (Document No. & paragraph)	Result - Remarks	Verdict
4.2	F60-SY-RA-SY-01-REV.I		Pass
4.3	F60-SY-RA-SY-01-REV.I		Pass
4.4	F60-SY-RA-SY-01-REV.I		Pass
5	F60-SY-RA-SY-01-REV.I		Pass
6.3	F60-SY-RA-SY-01-REV.I		Pass

7.2.17	RM RESULTS TABLE: Protective packaging		N/A
Clause of ISO 14971	Document Ref. in RMF (Document No. & paragraph)	Result - Remarks	Verdict
4.2			
4.3			
4.4			
5			
6.3			
6.4			

7.3.3	RM RESULTS TABLE: Batteries		Pass
Clause of ISO 14971	Document Ref. in RMF (Document No. & paragraph)	Result - Remarks	Verdict
4.2	F60-SY-RA-SY-01-REV.I		Pass
4.3	F60-SY-RA-SY-01-REV.I		Pass
4.4	F60-SY-RA-SY-01-REV.I		Pass
5	F60-SY-RA-SY-01-REV.I		Pass
6.3	F60-SY-RA-SY-01-REV.I		Pass

7.3.7	RM RESULTS TABLE: Supply terminals		N/A
Clause of ISO 14971	Document Ref. in RMF (Document No. & paragraph)	Result - Remarks	Verdict
4.3			

IEC 60601-1			
Clause	Requirement + Test	Result - Remark	Verdict
7.3.7	RM RESULTS TABLE: Supply terminals		N/A
Clause of ISO 14971	Document Ref. in RMF (Document No. & paragraph)	Result - Remarks	Verdict

7.4.2	RM RESULTS TABLE: Control devices		N/A
Clause of ISO 14971	Document Ref. in RMF (Document No. & paragraph)	Result - Remarks	Verdict
4.2			
4.3			
4.4			
5			
6.2			
6.3			

7.5	RM RESULTS TABLE: Safety signs		Pass
Clause of ISO 14971	Document Ref. in RMF (Document No. & paragraph)	Result - Remarks	Verdict
4.2	F60-SY-RA-SY-01-REV.I		Pass
4.3	F60-SY-RA-SY-01-REV.I		Pass
4.4	F60-SY-RA-SY-01-REV.I		Pass
5	F60-SY-RA-SY-01-REV.I		Pass
6.3	F60-SY-RA-SY-01-REV.I		Pass

7.9.1	RM RESULTS TABLE: General accompanying documents (See Table C.4)		Pass
Clause of ISO 14971	Document Ref. in RMF (Document No. & paragraph)	Result - Remarks	Verdict
4.2	F60-SY-RA-SY-01-REV.I		Pass
4.3	F60-SY-RA-SY-01-REV.I		Pass
4.4	F60-SY-RA-SY-01-REV.I		Pass
5	F60-SY-RA-SY-01-REV.I		Pass
6.2	F60-SY-RA-SY-01-REV.I		Pass
6.3	F60-SY-RA-SY-01-REV.I		Pass

7.9.2.4	RM RESULTS TABLE: Electrical power source		N/A
Clause of ISO 14971	Document Ref. in RMF (Document No. & paragraph)	Result - Remarks	Verdict
4.2			
4.3			
4.4			

IEC 60601-1			
Clause	Requirement + Test	Result - Remark	Verdict
7.9.2.4	<b>RM RESULTS TABLE: Electrical power source</b>		N/A
Clause of ISO 14971	Document Ref. in RMF (Document No. & paragraph)	Result - Remarks	Verdict
5			
6.3			
7.9.3.2	<b>RM RESULTS TABLE: Replacement of fuses, power supply cords, other parts</b>		N/A
Clause of ISO 14971	Document Ref. in RMF (Document No. & paragraph)	Result - Remarks	Verdict
4.2			
4.3			
4.4			
5			
6.2			
6.3			
6.4			
6.5			
8.1 b(1)	<b>RM RESULTS TABLE: Fundamental rule of protection against electric shock - interruption of any one power-carrying conductor</b>		Pass
Clause of ISO 14971	Document Ref. in RMF (Document No. & paragraph)	Result - Remarks	Verdict
4.3	F60-SY-RA-SY-01-REV.I		Pass
4.4	F60-SY-RA-SY-01-REV.I		Pass
8.1 b(2)	<b>RM RESULTS TABLE: Fundamental rule of protection against electric shock - unintended movement of a component</b>		N/A
Clause of ISO 14971	Document Ref. in RMF (Document No. & paragraph)	Result - Remarks	Verdict
4.2			
4.3			
4.4			
5			
6.2			
6.3			
6.4			
6.5			
8.1 b(3)	<b>RM RESULTS TABLE: Fundamental rule of protection against electric shock - accidental detachment of conductors and connectors</b>		Pass



IEC 60601-1			
Clause	Requirement + Test	Result - Remark	Verdict

Clause of ISO 14971	Document Ref. in RMF (Document No. & paragraph)	Result - Remarks	Verdict
4.3	F60-SY-RA-SY-01-REV.I		Pass

Clause of ISO 14971	Document Ref. in RMF (Document No. & paragraph)	Result - Remarks	Verdict
8.2.2	RM RESULTS TABLE: Connection to an external d.c. power sources		Pass
4.2	F60-SY-RA-SY-01-REV.I		Pass
4.3	F60-SY-RA-SY-01-REV.I		Pass
4.4	F60-SY-RA-SY-01-REV.I		Pass
5	F60-SY-RA-SY-01-REV.I		Pass

Clause of ISO 14971	Document Ref. in RMF (Document No. & paragraph)	Result - Remarks	Verdict
8.3 d	RM RESULTS TABLE: Requirements of Type BF or CF Applied Parts		Pass
6.2	F60-SY-RA-SY-01-REV.I		Pass

8.4.2	TABLE: TABLE: Working Voltage / Power Measurement					N/A
Test supply voltage/frequency (V/Hz) <sup>1</sup> .....						
Location From/To	Measured values					Remarks
	Vrms	Vpk or Vdc	Peak-to-peak ripple <sup>2</sup>	Power W/VA	Energy (J)	
<b>Supplementary Information:</b>						
1. The input supply voltage to the ME EQUIPMENT shall be the RATED voltage or the voltage within the RATED voltage range which results in the highest measured value. See clause 8.5.4.						
2. If the d.c peak-to-peak ripple >10%, waveform considered as a.c. See clause 8.4.2.2						

8.4.2 c	RM RESULTS TABLE: Accessible parts including applied parts		N/A
Clause of ISO 14971	Document Ref. in RMF (Document No. & paragraph)	Result - Remarks	Verdict
4.2			
4.3			
4.4			



IEC 60601-1										
Clause	Requirement + Test	Result - Remark								Verdict
8.4.3	TABLE: ME EQUIPMENT for connection to a power source by a plug - measurement of voltage or calculation of stored charge 1 s after disconnection of plug from mains supply								P	
Maximum allowable voltage (V) .....									60	
Voltage measured (V)										
Voltage Measured Between:	1	2	3	4	5	6	7	8	9	10
Plug pins 1 and 2	0	0	0	0	0	0	0	0	0	0
Plug pin 1 and plug earth pin	N/A	N/A	N/A	N/A	N/A	N/A	N/A	N/A	N/A	N/A
Plug pin 2 and plug earth pin	N/A	N/A	N/A	N/A	N/A	N/A	N/A	N/A	N/A	N/A
Plug pin 1 and enclosure	0	0	0	0	0	0	0	0	0	0
Plug pin 2 and enclosure	0	0	0	0	0	0	0	0	0	0
Maximum allowable stored charge when measured voltage exceeded 60 v ( $\mu\text{C}$ ) .....									45	
Calculated stored charge ( $\mu\text{C}$ )										
Voltage Measured Between:	1	2	3	4	5	6	7	8	9	10
Plug pins 1 and 2										
Plug pin 1 and plug earth pin										
Plug pin 2 and plug earth pin										
Plug pin 1 and enclosure										
Plug pin 2 and enclosure										
Supplementary information:										

8.4.4	TABLE: Internal capacitive circuits – measurement of residual voltage or calculation of the stored charge in capacitive circuits (i.e., accessible capacitors or circuit parts) after de-energizing ME EQUIPMENT								N/A	
Maximum allowable residual voltage (V):										
Maximum allowable stored charge when residual voltage exceeded 60 V :										
Description of the capacitive circuit (i.e., accessible capacitor or circuit parts)	Measured residual voltage (V)	Calculated stored charge ( $\mu\text{C}$ )					Remarks			
Supplementary information:										

IEC 60601-1			
Clause	Requirement + Test	Result - Remark	Verdict
8.5.2.2	RM RESULTS TABLE: Type B applied parts		N/A
Clause of ISO 14971	Document Ref. in RMF (Document No. & paragraph)	Result - Remarks	Verdict
4.2			
4.3			
4.4			
5			

8.5.2.3	RM RESULTS TABLE: PATIENT Leads		NA
Clause of ISO 14971	Document Ref. in RMF (Document No. & paragraph)	Result - Remarks	Verdict
4.2			
4.3			
4.4			
5			

8.5.5.1a	TABLE: defibrillation-proof applied parts – measurement of hazardous electrical energies				N/A
Test Condition: Figs. 9 & 10	Measurement made on accessible part	Applied part with test voltage	Test voltage polarity	Measured voltage between Y1 and Y2 (mV)	Remarks

Supplementary information:

8.5.5.1b	TABLE: defibrillation-proof applied parts – verification of recovery time				N/A
Applied part with test voltage	Test voltage polarity	Recovery time from documents (s)	Measured recovery time (s)	Remarks	

Supplementary information:

IEC 60601-1			
Clause	Requirement + Test	Result - Remark	Verdict
8.5.5.2	<b>TABLE: DEFIBRILLATION-PROOF APPLIED PARTS OF PATIENT CONNECTIONS OF DEFIBRILLATION-PROOF APPLIED PARTS - Energy reduction test –measurement of Energy delivered to a 100 Ω load</b>		N/A
	<b>Test Voltage applied to</b>	<b>Measured Energy E1 (mJ)</b>	<b>Measured Energy E2 (mJ)</b>
	<b>Energy E1 as % of E2 (%)</b>		
	<b>PATIENT CONNECTION 1 or APPLIED PART with PATIENT CONNECTIONS 2, 3, and 4 of the same APPLIED PART connected to earth</b>		
	<b>PATIENT CONNECTION 2 or APPLIED PART with PATIENT CONNECTIONS 1, 3, and 4 of the same APPLIED PART connected to earth</b>		
	<b>PATIENT CONNECTION 3 or APPLIED PART with PATIENT CONNECTIONS 1, 2, and 4 of the same APPLIED PART connected to earth</b>		
	<b>PATIENT CONNECTION 4 or APPLIED PART with PATIENT CONNECTIONS 1, 2, and 3 of the same APPLIED PART connected to earth</b>		
<b>Supplementary information:</b> For compliance: E1 must at least 90% of E2 E1= Measured energy delivered to 100 Ω with ME Equipment connected; E2= Measured energy delivered to 100 Ω without ME equipment connected.			

8.6.3	<b>RM RESULTS TABLE: Protective earthing of moving parts</b>		N/A
Clause of ISO 14971	Document Ref. in RMF (Document No. & paragraph)	Result - Remarks	Verdict
4.2			
4.3			
4.4			
5			
6.2			
6.3			
6.4			
6.5			



IEC 60601-1				
Clause	Requirement + Test	Result - Remark		Verdict
8.6.4	<b>TABLE: Impedance and current-carrying capability of PROTECTIVE EARTH CONNECTIONS</b>			N/A
Type of ME EQUIPMENT & impedance measured between parts	Test current (A) /Duration (s)	Voltage drop measured between parts (V)	Maximum calculated impedance (mΩ)	Maximum allowable impedance (mΩ)
PERMANENTLY INSTALLED ME EQUIPMENT, impedance between PROTECTIVE EARTH TERMINAL and a PROTECTIVELY EARTHED part	---	---	---	100
ME EQUIPMENT with an APPLIANCE INLET, impedance between earth pin in the APPLIANCE INLET and a PROTECTIVELY EARTHED part (rear panel)	---	---	---	100
ME EQUIPMENT with a non-DETACHABLE POWER SUPPLY CORD, impedance between the protective earth pin in the MAINS PLUG and a PROTECTIVELY EARTHED part	---	---	---	200
Supplementary information:				

IEC 60601-1				
Clause	Requirement + Test	Result - Remark		Verdict
8.7	TABLE: leakage current			Pass
Type of leakage current and test condition (including single faults)	Supply voltage (V)	Supply frequency (Hz)	Measured max. value (µA)	Remarks
Fig. 13 - Earth Leakage (ER)	—	—	—	Maximum allowed values: 5 mA NC; 10 mA SFC
Fig. 14 - Touch Current (TC)	—	—	—	Maximum allowed values: 100 uA NC; 500 uA SFC
TC, NC (S5-1, S12-1, S1-1)	264	60	35	Metal Parts
TC, NC (S5-0, S12-1, S1-1)	264	60	36	Metal Parts
TC, NC (S5-1, S12-0, S1-1)	264	60	35	Metal Parts
TC, NC (S5-0, S12-0, S1-1)	264	60	36	Metal Parts
TC, SFC (S5-1, S12-1, S1-0)	264	60	65	Metal Parts
TC, SFC (S5-0, S12-1, S1-0)	264	60	64	Metal Parts
TC, SFC (S5-1, S12-0, S1-0)	264	60	65	Metal Parts
TC, SFC (S5-0, S12-0, S1-0)	264	60	64	Metal Parts
TC, NC (S5-1, S12-1, S1-1)	264	60	6.2	Plastic Parts
TC, NC (S5-0, S12-1, S1-1)	264	60	5.6	Plastic Parts
TC, NC (S5-1, S12-0, S1-1)	264	60	5.2	Plastic Parts
TC, NC (S5-0, S12-0, S1-1)	264	60	4.5	Plastic Parts
TC, SFC (S5-1, S12-1, S1-0)	264	60	7.5	Plastic Parts
TC, SFC (S5-0, S12-1, S1-0)	264	60	6.8	Plastic Parts
TC, SFC (S5-1, S12-0, S1-0)	264	60	7.1	Plastic Parts
TC, SFC (S5-0, S12-0, S1-0)	264	60	7.2	Plastic Parts
Fig. 15 - Patient Leakage Current (P)	—	—	—	Maximum allowed values: Type B or BF AP: 10 uA NC; 50 uA SFC (d.c. current); 100 uA NC; 500 uA SFC (a.c.) Type CF AP: 10 uA NC; 50 uA SFC (d.c. or a.c. current)
P, NC (S5-1, S13-1, S1-1)	264	60	4.1	
P, NC (S5-0, S13-1, S1-1)	264	60	4.2	
P, NC (S5-1, S13-0, S1-1)	264	60	6.1	
P, NC (S5-0, S13-0, S1-1)	264	60	6.0	
P, SFC (S5-1, S13-1, S1-0)	264	60	5.1	
P, SFC (S5-0, S13-1, S1-0)	264	60	4.9	
P, SFC (S5-1, S13-0, S1-0)	264	60	8.7	
Fig. 16 - Patient leakage current with	—	—	—	Maximum allowed values:

IEC 60601-1					
Clause	Requirement + Test			Result - Remark	Verdict
mains on the F-type applied parts (PM)				Type B: N/A Type BF AP: 5000 uA Type CF AP: 50 uA	
PM (S5-1, S9-1, S13-1, S1-1)	264	60	7.4		
PM (S5-0, S9-1, S13-1, S1-1)	264	60	7.3		
PM (S5-1, S9-0, S13-1, S1-1)	264	60	2.1		
PM (S5-0, S9-0, S13-1, S1-1)	264	60	2.1		
PM (S5-1, S9-1, S13-0, S1-1)	264	60	7.2		
PM (S5-0, S9-1, S13-0, S1-1)	264	60	7.2		
PM (S5-1, S9-0, S13-0, S1-1)	264	60	2.3		
PM (S5-0, S9-0, S13-0, S1-1)	264	60	2.3		
Fig. 17 - Patient leakage current with external voltage on Signal Input/Output part (SIP/SOP)	—	—	—	Maximum allowed values: Type B or BF AP: 10 uA NC; 50 uA SFC(d.c. current); 100 uA NC; 500 uA SFC (a.c.) ; Type CF AP: 10 uA NC; 50 uA SFC (d.c. or a.c. current)	
SIP/SOP, NC (S5-1, S13-1, S1-1)	264	60	1.1		
SIP/SOP, NC (S5-0, S13-1, S1-1)	264	60	1.2		
SIP/SOP, NC (S5-1, S13-0, S1-1)	264	60	1.1		
SIP/SOP, NC (S5-0, S13-0, S1-1)	264	60	1.1		
SIP/SOP, SFC (S5-1, S13-1, S1-0)	264	60	0.9		
SIP/SOP, SFC (S5-0, S13-1, S1-0)	264	60	0.8		
SIP/SOP, SFC (S5-1, S13-0, S1-0)	264	60	0.8		
SIP/SOP, SFC (S5-0, S13-0, S1-0)	264	60	0.9		
Fig. 18 - Patient leakage current with external voltage on metal Accessible Part that is not Protectively Earthed	—	—	—	Maximum allowed values: Type B or BF AP: 500 uA Type CF: N/A	
(S5-1, S1-1)	264	60	1.2		
(S5-0, S1-1)	264	60	1.1		
Fig. 19 – Patient Auxiliary Current	—	—	—	Maximum allowed values: Type B or BF AP: 10 uA NC; 50 uA SFC (d.c. current); 100 uA NC; 500 uA SFC (a.c.) ; Type CF AP: 10 uA NC;50 uA SFC (d.c. or a.c. current)	
NC (S5-1, S1-1)	264	60	1.2		
NC (S5-0, S1-1)	264	60	1.2		
SFC (S5-1, S1-0)	264	60	1.2		
SFC (S5-0, S1-0)	264	60	1.2		
Fig. 17 and 20 – Total Patient Leakage Current with all AP of same type connected together with external voltage on SIP/SOP	—	—	—	Maximum allowed values: Type B or BF AP: 50 uA NC; 100uA SFC (d.c. current); 500 uA NC;1000 uA SFC (a.c.);	



IEC 60601-1					
Clause	Requirement + Test			Result - Remark	Verdict
				Type CF AP: 50 uA NC; 100 uA SFC (d.c. or a.c. current)	
Fig. 16 and 20 – Total Patient Leakage Current with all AP of same type connected together with external voltage on F-type AP	—	—	—	Maximum allowed values: Type B: NA Type BF: 5000uA Type CF: 100 uA	
Fig. 18 and 20 – Total Patient Leakage Current with all AP of same type connected together with external voltage on metal Accessible Part not Protectively Earthed	—	—	—	Maximum allowed values: Type B & BF: 1000 uA Type CF: N/A	
<b>Supplementary information:</b>					
<p>Note 1: For EARTH LEAKAGE CURRENT see 8.7.3 d) and 8.7.4.5;            Note 2: For TOUCH CURRENT see 8.7.3 c) and 8.7.4.6;            Note 3: For PATIENT LEAKAGE CURRENT SEE 8.7.3.b) and 8.7.4.7            Note 4: Total PATIENT LEAKAGE CURRENT values are only relative to equipment with multiple APPLIED PARTS of the same type. See 8.7.4.7 h). The individual APPLIED PARTS complied with the PATIENT LEAKAGE CURRENT values.            Note 5: In addition to conditions indicated in the Table, tests conducted at operating temperature and after humidity preconditioning of 5.7, EQUIPMENT energized in stand-by condition and fully operating, max rated supply frequency, at 110 % of the max RATED MAINS VOLTAGE, and after relevant tests of Clause 11.6 (i.e., overflow, spillage, leakage, ingress of water and particulate matter, cleaning &amp; disinfection, &amp; sterilization).  <b>Note 6: No patient leakage current was performed as there is no physical contact between the controller unit and beam micromanipulator assembly The only contact with the patient is the CO2 laser beam which is not part of this evaluation.</b></p>					
<p>Flight 60 Ver. D : Class I            Flight 60 : Class II</p>					
<p>ER - Earth leakage current            TC – Touch current            P - Patient leakage current            PA – Patient auxiliary current            TP – Total Patient current            PM - Patient leakage current with mains on the applied parts            MD - Measuring device</p>					
<p>A - After humidity conditioning            B - Before humidity conditioning            1 - Switch closed or set to normal polarity            0 - Switch open or set to reversed polarity            NC - Normal condition            SFC - Single fault condition</p>					

IEC 60601-1			
Clause	Requirement + Test	Result - Remark	Verdict

8.8.3	<b>TABLE: Dielectric strength test of solid insulating materials with safety function – MEANS OF OPERATOR PROTECTION (MOOP) / MEANS OF PATIENT PROTECTION (MOPP)</b>		<b>P</b>
-------	--	--	----------

Insulation under test (area from insulation diagram)	Insulation Type (1 or 2 MOOP/MOPP)	Reference Voltage		A.C. test voltages in V r.m.s <sup>1</sup>	Dielectric breakdown after 1 minute Yes/No <sup>2</sup>
		PEAK WORKING VOLTAGE (U) V <sub>peak</sub>	PEAK WORKING VOLTAGE (U) V d.c.		
(A) L/N to Applied Part	2 MOPP	340	--	4000	No
(B) L/N to Back Metal parts	2 MOOP	340	--	3000	No
(C) L/N to Plastic enclosure	2 MOPP	340	--	4000	No

**Supplementary information:**

<sup>1</sup> Alternatively, per the Table (i.e., \_\_\_dc), a d.c. test voltage equal to the peak value of the a.c. test voltage used.

<sup>2</sup> A) Immediately after humidity treatment of 5.7, ME EQUIPMENT de-energized, B) after required sterilization PROCEDURE, ME EQUIPMENT de-energized, C) after reaching steady state operating temperature as during heating test of 11.1.1, and D) after relevant tests of 11.6 (i.e., overflow, spillage, leakage, ingress of water, cleaning, disinfection, and sterilization).

Note\*: Humidity conditioning: ambient temperature: 25.0 °C ,Humidity: 57%, Atm.Pressure : 760 mmHg

Note\*\*: Dielectric strength test performed before and after humidity conditioning

8.8.4.1	<b>TABLE: Resistance to heat - Ball pressure test of thermoplastic parts</b>		<b>Pass</b>
	Allowed impression diameter (mm) .....	≤ 2 mm	—
	Force (N) .....	20	—

Part/material	Test temperature (°C)	Impression diameter (mm)
<b>Enclosure/External insulating parts:</b>		
Ball Pressure test on the main unit enclosure	75	0.1
<b>Insulating material supporting uninsulated Mains Parts:</b>		

**Supplementary information:**



IEC 60601-1			
Clause	Requirement + Test	Result - Remark	Verdict

8.8.4.1	RM RESULTS TABLE: Mechanical strength and resistance to heat		Pass
Clause of ISO 14971	Document Ref. in RMF (Document No. & paragraph)	Result - Remarks	Verdict
4.2	F60-SY-RA-SY-01-REV.I		Pass
4.3	F60-SY-RA-SY-01-REV.I		Pass
4.4	F60-SY-RA-SY-01-REV.I		Pass
5	F60-SY-RA-SY-01-REV.I		Pass
6.2	F60-SY-RA-SY-01-REV.I		Pass
6.3	F60-SY-RA-SY-01-REV.I		Pass
6.4	F60-SY-RA-SY-01-REV.I		Pass
6.5	F60-SY-RA-SY-01-REV.I		Pass

8.9.2	TABLE: Short circuiting of each single one of the CREEPAGE DISTANCES and AIR CLEARANCES for insulation in the MAINS PART between parts of opposite polarity in lieu of complying with the required measurements in 8.9.4			N/A
Specific areas of circuits short-circuited and test conditions	Test in lieu of CREEPAGE DISTANCE or AIR CLEARANCE <sup>1</sup>	HAZARDOUS SITUATION observed (i.e., fire hazard, shock hazard, explosion, discharge of parts, etc.)? Yes/No	Remarks	

**Supplementary information:**  
Note 1: AC - AIR CLEARANCE CD - CREEPAGE DISTANCE





IEC 60601-1			
Clause	Requirement + Test	Result - Remark	Verdict

8.9.3.4	Table: Thermal cycling tests on one sample of cemented joint (see 8.9.3.3)		N/A
Test Sequence No.	Each test duration and temperature	Dielectric test voltage (V = Test voltage in 8.8.3 times 1.6)	Dielectric strength test after humidity preconditioning per cl. 5.7 except for 48 h only, Breakdown: Yes/No
1	68 h at T1 ± 2 °C = ___ °C <sup>1</sup>		
	1 h at 25 °C ± 2 °C		
	2 h at 0 °C ± 2 °C		
	1 or more h at 25 °C ± 2 °C		
2	68 h at T1 ± 2 °C = ___ °C <sup>1</sup>		
	1 h at 25 °C ± 2 °C		
	2 h at 0 °C ± 2 °C		
	1 or more h at 25 °C ± 2 °C		
3	68 h at T1 ± 2 °C = ___ °C <sup>1</sup>		
	1 h at 25 °C ± 2 °C		
	2 h at 0 °C ± 2 °C		
	1 or more h at 25 °C ± 2 °C		
4	68 h at T1 ± 2 °C = ___ °C <sup>1</sup>		
	1 h at 25 °C ± 2 °C		
	2 h at 0 °C ± 2 °C		
	1 or more h at 25 °C ± 2 °C		

**Supplementary information:**

<sup>1</sup> T1 = 10 °C above the maximum temperature of relevant part determined per 11.1.1, or 85 °C, the higher of the two. 10 °C not added to T1 when temperature measured by an embedded thermocouple. Used gradual transition from one temperature to another.

IEC 60601-1			
Clause	Requirement + Test	Result - Remark	Verdict

8.10	TABLE: List of critical components					Pass
Component/ Part No.	Manufacturer/ Trademark	Type No./model No./	Technical data	Standard No./, Edition	Mark(s) & Certificates of conformity <sup>1</sup>	
EUT + Batteries enclosure	Polyram	PC/ABS V0-EXP10198 or PC/ABS V0-EXP10199 PBB5582BL-COP	Flammability: V-0 Min. Thick: 2 mm	UL 94	UL	
Wiring in Primary	Alfha Wire / Interchangeable	461816 / Interchangeable	UL 1015, UL1230, Rated: 600V, 18AWG, -40°C to +105°C	UL 758	UL (E163869)	
Battery Pack Detachable	Epsilor-Electric Fuel Ltd.	ELI-0815	14.8V, 2600mA, 8x3.7Vx2.6AH Lithium-ion Rechargeable Cells (4 serial cells parallel to 4 serial cells) + PCM	IEC 60601-1	Tested in the unit	
Battery Pack Integral	Epsilor-Electric Fuel Ltd.	ELI-0415	14.8V, 2600mA, 4x3.7Vx2.6AH Lithium-ion Rechargeable Cells (4 serial cells) + PCM	IEC 60601-1	Tested in the unit	
Batteries Cell for batteries packs	Samsung	ICR18650-26A	3.7V , 2600mAh, Lithium-ion Rechargeable Cell, Charging 4.2V, 2600mA max, Discharge 5200mA max, cut-off 2.75V, operation Temp 60°C max	UL 1642	cURus MH 21015	
Batteries cells plastic tube	Moodeung Co. Ltd.	MU - 55	Flammability: VW-1 Need data sheets, Thick: 0.12 +/- 0.02 mm	UL 94 UL 746	cURus (E12947)	
Battery charger IC	Linear Technology	LTC4007EGN	Stand alone Li-Ion Battery Charger. Input 6-28V operation current 5mA max, Output Currents Exceeding 4A, operation temperature -40°C to 85°C	UL 60601-1	Tested in the unit	

IEC 60601-1					
Clause	Requirement + Test			Result - Remark	Verdict
Blower	Micronel	U65H4-024KX-6	Miniature Radial Blower with integrated NTC sensor. Housing Polycarbonate (PC), Electric connection lead wire 24AWG UL3132 Free blowing power 41W, 2.27A, Air flow 330 l/min, max temperature 85°C on heat sink, operation Temp max 65°C	IEC 60601-1	Tested in the unit
Blower NTC, installed in blower)	Epcos	B57421V2103J062	SMD case 0805 NTC thermistor, 10 Kohm Art. No. B57421V2103J062 Characteristic: R/T 8502	UL 1434, IEC 60068	cURus (E69802)
Brushless DC Motor Controller	On semiconductor	MC33035DW	10 to 30V Operation, Power Supply Voltage maximum 40V, Cycle-By-Cycle Current Limiting	IEC 60601-1	Tested in the unit
Pressure sensor	Freescaler Semiconductor	MPXV2010DP or MPXM2010GS	Differential. 10kPa On-Chip Temperature Compensated 0°C to +85°C	IEC 60601-1	Tested in the unit
Oxygen sensor Qty 2	Analytical industries	PSR-11-917-M	Oxygen sensor Range 0-100% C <sub>2</sub> output 9-14mV, operation Temp 0-45°C	IEC 60601-1	Tested in the unit
Air Safety valve	parker	11-18-4-BV-12 or 11-18-4-SV-12	15mm Digital Solenoid Valve, 3-WayNO, Brass/FKM, 12Vdc.	IEC 60601-1	Tested in the unit
Oxygen Proportional Valve	Parker	921-111051-000	Flow Valve type 2-way normally closed, power 5V, 2W, operation Temp 5-55°C, max flow capabilities 240slpm	IEC 60601-1	Tested in the unit
VALVE NEBULIZER	Parker	SRS-14-1-PV-5-L	10mm manifold mount Solenoid Valve, Power 5V, 1W, 3 way-NC	IEC 60601-1	Tested in the unit
Purge pump Qty 2, (Rolling pumps)	Okenseiko	P21B01	Air Pump, Rated 3Vdc, 320mA, max pressure 60KPa	IEC 60601-1	Tested in the unit
Air Flow sensor Differential pressure sensor	Honeywell	DCXL01DS	operating pressure 1 H <sub>2</sub> O, 11mV max, common mode voltage 6V	IEC 60601-1	Tested in the unit
Differential pressure sensor (Oxygen Flow measurement)	Sensirion	SDP1108-R	Differential pressure sensor, power 5V output 4V max	IEC 60601-1	Tested in the unit



IEC 60601-1					
Clause	Requirement + Test			Result - Remark	Verdict
Power DC cable	interchangeable	interchangeable	18AWG,2 hook-up wires , PVC, 300V , double insulation.	UL 83	UL
Power DC cable Fuse	Littlefuse	FLM 8	5X20mm Ceramic body Slow blow Cartridge Fuses 8A, 250V	UL 248	UR (E10480)
AC Power Entry + Fuse holder	Schurter	6202-2100	1 –Pole Class II C18 inlet, Panel mount with fuse holder 10 A / 250 VAC, Dielectric Strength 4 kVAC between L-N, operation temperature - 25°C +70°C	IEC 60320, UL 498, IEC 60127-6	UR, (E93617) CSA (32338) VDE (40011091)
Mains Fuse	Littelfuse	0215.008P	5x20mm Ceramic Body Time-Lag Cartridge Fuse 8A 250V	UL 248	UR,(E10480) CSA,(029862) VDE(40013521)
Power supply	Roal living energy	MFA160-US24-2	Input:100-240Vac, 2A 50/60Hz, Output:V1-24Vdc ,6.6A,V2- 12Vdc ,0.5A	IEC/UL 60601-1	cCSA us (2022889)
Power supply enclosure	Power Conversion	LPX50	Stainless steel Overall dimensions 119/74.8/43mm, thick 5mm material PBT film , flammability 94VTN-0	UL 94	UL
Power supply Insulator sheet (under power supply PCB)	Astec	LPX50 (P/N 037-7200005A-JA)	dimensions 114.6/70.4mm thick 0.5mm,material PBT film, flammability 94VTN-0,	UL94	UL (E61257)
Isolation Film (attached to PSU enclosure)	Pronat	YWO-KPT-0130R-01	polyimide film antistatic, single coated tape with silicone adhesive. Insulation class (a),200°C	UL 510	UL E230272
Heat Shrink Tubing (on Mains PSU AC connector and wires)	3M	EPS-300	600V 125°C, operation Temp -55°C to 110°C, Dielectric Strength 700 V/mil	UL 224	UR (E157227) CSA (file LR38227)
booster card Fuse	Littelfuse	0469008.WR	SMT 1206,ceramic, Slow blow Fuse 8A, 24V	UL 248	UR (E10480)
PCB	interchangeable	interchangeable	Flame rated min:V-1	UL 94, UL 746	UL
Product Label material	Nortec / interchangeable	A711 / interchangeable	2.0 mil Gloss top-coated thermal transfer printable white polyester film. Temp -40°C to 150°C.	UL969	UL (MH 29261)
<b>Supplementary information:</b>					
1) An asterisk indicates a mark which assures the agreed level of surveillance. See Licenses and Certificates of Conformity for verification.					

8.10.1	RM RESULTS TABLE: Fixing of components	Pass
--------	--	------

IEC 60601-1			
Clause	Requirement + Test	Result - Remark	Verdict

Clause of ISO 14971	Document Ref. in RMF (Document No. & paragraph)	Result - Remarks	Verdict
4.2	F60-SY-RA-SY-01-REV.I		Pass
4.3	F60-SY-RA-SY-01-REV.I		Pass
4.4	F60-SY-RA-SY-01-REV.I		Pass
5	F60-SY-RA-SY-01-REV.I		Pass
6.2	F60-SY-RA-SY-01-REV.I		Pass
6.3	F60-SY-RA-SY-01-REV.I		Pass
6.4	F60-SY-RA-SY-01-REV.I		Pass
6.5	F60-SY-RA-SY-01-REV.I		Pass

8.10.2 RM RESULTS TABLE: Fixing of wiring			
Clause of ISO 14971	Document Ref. in RMF (Document No. & paragraph)	Result - Remarks	Verdict
4.3	F60-SY-RA-SY-01-REV.I		Pass
4.4	F60-SY-RA-SY-01-REV.I		Pass
5	F60-SY-RA-SY-01-REV.I		Pass
6.2	F60-SY-RA-SY-01-REV.I		Pass
6.3	F60-SY-RA-SY-01-REV.I		Pass
6.4	F60-SY-RA-SY-01-REV.I		Pass
6.5	F60-SY-RA-SY-01-REV.I		Pass

8.10.5 RM RESULTS TABLE: Mechanical protection of wiring			
Clause of ISO 14971	Document Ref. in RMF (Document No. & paragraph)	Result - Remarks	Verdict
4.3	F60-SY-RA-SY-01-REV.I		Pass
4.4	F60-SY-RA-SY-01-REV.I		Pass
5	F60-SY-RA-SY-01-REV.I		Pass
6.2	F60-SY-RA-SY-01-REV.I		Pass
6.3	F60-SY-RA-SY-01-REV.I		Pass
6.4	F60-SY-RA-SY-01-REV.I		Pass
6.5	F60-SY-RA-SY-01-REV.I		Pass

8.11.3.5 TABLE: Cord anchorages				N/A
Cord under test	Mass of equipment (kg)	N/A	Torque Nm)	Remarks
		N/A		

Supplementary information:

IEC 60601-1			
Clause	Requirement + Test	Result - Remark	Verdict
8.11.3.6	TABLE: Cord guard		N/A
Cord under test	Test mass	N/A	Remarks
		N/A	
Supplementary information:			

8.11.5	RM RESULTS TABLE: Mains fuses and over-current releases		N/A
Clause of ISO 14971	Document Ref. in RMF (Document No. & paragraph)	Result - Remarks	Verdict
4.3			
4.4			
5			
6.2			
6.3			
6.4			
6.5			

9.2.1	RM RESULTS TABLE: HAZARDS associated with moving parts - General		N/A
Clause of ISO 14971	Document Ref. in RMF (Document No. & paragraph)	Result - Remarks	Verdict
4.2			
4.3			
4.4			
5			
6.2			
6.3			
6.4			
6.5			

9.2.2.2	TABLE: Measurement of gap "a" according to Table 20 (ISO 13852: 1996)			N/A
Part of body	Allowable adult gap <sup>1</sup> , mm	Measured adult gap, mm	Allowable children gap <sup>1</sup> , mm	Measured children gap, mm
Body	> 500		> 500	
Head	> 300 or < 120		> 300 or < 60	
Leg	> 180		> 180	
Foot	> 120 or < 35		> 120 or < 25	
Toes	> 50		> 50	
Arm	> 120		> 120	
Hand, wrist, fist	> 100		> 100	
Finger	> 25 or < 8		> 25 or < 4	

IEC 60601-1			
Clause	Requirement + Test	Result - Remark	Verdict

**Supplementary information:** <sup>1</sup> In general, gaps for adults used, except when the device is specifically designed for use with children, values for children applied.

9.2.2.4.3 RM RESULTS TABLE: Movable guards			N/A
Clause of ISO 14971	Document Ref. in RMF (Document No. & paragraph)	Result - Remarks	Verdict
4.2			
4.3			
4.4			
5			
6.2			
6.3			
6.4			
6.5			

9.2.2.4.4 RM RESULTS TABLE: Protective measures			N/A
Clause of ISO 14971	Document Ref. in RMF (Document No. & paragraph)	Result - Remarks	Verdict
4.2			
4.3			
4.4			
5			
6.2			
6.3			
6.4			
6.5			

9.2.2.5 c) RM RESULTS TABLE: Continuous activation			N/A
Clause of ISO 14971	Document Ref. in RMF (Document No. & paragraph)	Result - Remarks	Verdict
4.2			
4.3			
4.4			
5			
6.2			
6.3			
6.4			
6.5			

9.2.2.6 RM RESULTS TABLE: Speed of movement(s)			N/A
--	--	--	-----



IEC 60601-1			
Clause	Requirement + Test	Result - Remark	Verdict
Clause of ISO 14971	Document Ref. in RMF (Document No. & paragraph)	Result - Remarks	Verdict
4.2			
4.3			
4.4			
5			
6.2			
6.3			
6.4			
6.5			

9.2.3.2		RM RESULTS TABLE: Over travel	N/A
Clause of ISO 14971	Document Ref. in RMF (Document No. & paragraph)	Result - Remarks	Verdict
4.2			
4.3			
4.4			
5			
6.2			
6.3			
6.4			
6.5			

9.2.4		RM RESULTS TABLE: Emergency stopping devices	N/A
Clause of ISO 14971	Document Ref. in RMF (Document No. & paragraph)	Result - Remarks	Verdict
4.2			
4.3			
4.4			
5			
6.2			
6.3			
6.4			
6.5			
6.6			

IEC 60601-1			
Clause	Requirement + Test	Result - Remark	Verdict
9.2.5	RM RESULTS TABLE: Release of patient		N/A
Clause of ISO 14971	Document Ref. in RMF (Document No. & paragraph)	Result - Remarks	Verdict
4.2			
4.3			
4.4			
5			
6.2			
6.3			
6.4			
6.5			

9.3	RM RESULTS TABLE: Hazards associated with surfaces, corners and edges		Pass
Clause of ISO 14971	Document Ref. in RMF (Document No. & paragraph)	Result - Remarks	Verdict
4.3	F60-SY-RA-SY-01-REV.I		Pass
4.4	F60-SY-RA-SY-01-REV.I		Pass
5	F60-SY-RA-SY-01-REV.I		Pass
6.2	F60-SY-RA-SY-01-REV.I		Pass
6.3	F60-SY-RA-SY-01-REV.I		Pass
6.4	F60-SY-RA-SY-01-REV.I		Pass
6.5	F60-SY-RA-SY-01-REV.I		Pass

9.4.2.1	TABLE: Instability—overbalance in transport position		Pass
ME EQUIPMENT preparation	Test Condition (transport position)	Remarks	
UUT is provided with all the accessories connected in the position most unfavorable for stability	The unit was inclined 10° from the horizontal plane	No overbalance or any unacceptable RISK observed	
<b>Supplementary information:</b>			

9.4.2.2	TABLE: Instability—overbalance excluding transport position		Pass
ME EQUIPMENT preparation	Test Condition (excluding transport position) Test either 5 ° incline and verify Warning marking or 10 ° incline)	Remarks	
UUT is provided with all the accessories connected in the position most unfavorable for stability	The unit was inclined 10° from the horizontal plane	No overbalance or any unacceptable RISK observed	



IEC 60601-1			
Clause	Requirement + Test	Result - Remark	Verdict
Supplementary information:			

9.4.2.3	TABLE: Instability—overbalance from horizontal and vertical forces		N/A
ME EQUIPMENT preparation	Test Condition (force used, direction of force, weight of equipment, location of force)	Remarks	
Supplementary information:			

9.4.2.4.2	TABLE: Castors and wheels – Force for propulsion		N/A
ME EQUIPMENT preparation	Test Condition (force location and height)	Remarks	
Supplementary information:			

9.4.2.4.3	TABLE: Castors and wheels – Movement over a threshold		N/A
ME EQUIPMENT preparation	Test Condition (speed of movement)	Remarks	
Supplementary information:			

9.4.2.4.3	RM RESULTS TABLE: Movement over a threshold		N/A
Clause of ISO 14971	Document Ref. in RMF (Document No. & paragraph)	Result - Remarks	Verdict
4.2			
4.3			
4.4			
5			
6.2			
6.3			

IEC 60601-1			
Clause	Requirement + Test	Result - Remark	Verdict
9.4.2.4.3	RM RESULTS TABLE: Movement over a threshold		N/A
Clause of ISO 14971	Document Ref. in RMF (Document No. & paragraph)	Result - Remarks	Verdict
6.4			
6.5			

9.4.3.1	TABLE: Instability from unwanted lateral movement (including sliding) in transport position		N/A
ME EQUIPMENT Preparation	Test Condition (transport position, working load, locking device(s), caster position)	Remarks	
Supplementary information:			

9.4.3.2	TABLE: Instability from unwanted lateral movement (including sliding) excluding transport position		N/A
ME EQUIPMENT Preparation	Test Condition (working load, locking device(s), caster position, force, force location, force direction)	Remarks	
Supplementary information:			

9.4.4	TABLE: Grips and other handling devices		N/A
Clause and Name of Test	Test Condition	Remarks	
Supplementary information:			

9.5.1	RM RESULTS TABLE: Protective means		N/A
Clause of ISO 14971	Document Ref. in RMF (Document No. & paragraph)	Result - Remarks	Verdict
4.3			
4.4			
5			



IEC 60601-1			
Clause	Requirement + Test	Result - Remark	Verdict
9.5.1	RM RESULTS TABLE: Protective means		N/A
Clause of ISO 14971	Document Ref. in RMF (Document No. & paragraph)	Result - Remarks	Verdict
6.2			
6.3			
6.4			
6.5			

IEC 60601-1			
Clause	Requirement + Test	Result - Remark	Verdict

9.6.1	RM RESULTS TABLE: Acoustic energy - General		N/A
Clause of ISO 14971	Document Ref. in RMF (Document No. & paragraph)	Result - Remarks	Verdict
4.2			
4.3			
4.4			
5			
6.2			
6.3			
6.4			
6.5			

9.6.2.2	RM RESULTS TABLE: Infrasound and ultrasound energy		N/A
Clause of ISO 14971	Document Ref. in RMF (Document No. & paragraph)	Result - Remarks	Verdict
4.2			
4.3			
4.4			
5			
6.2			
6.3			
6.4			
6.5			

9.7.2	RM RESULTS TABLE: Pneumatic and hydraulic parts		N/A
Clause of ISO 14971	Document Ref. in RMF (Document No. & paragraph)	Result - Remarks	Verdict
4.3			
4.4			
5			
6.2			
6.3			
6.4			
6.5			

IEC 60601-1			
Clause	Requirement + Test	Result - Remark	Verdict

9.7.4	RM RESULTS TABLE: Pressure rating of ME equipment parts		N/A
Clause of ISO 14971	Document Ref. in RMF (Document No. & paragraph)	Result - Remarks	Verdict
4.3			
4.4			
5			
6.2			
6.3			
6.4			
6.5			

9.7.5	TABLE: Pressure vessels					N/A
Hydraulic, Pneumatic or Suitable Media and Test Pressure	Vessel Burst	Permanent Deformation	Leaks	Vessel fluid substance	Remarks	

Supplementary Information:

9.7.6	RM RESULTS TABLE: Pressure-control device		N/A
Clause of ISO 14971	Document Ref. in RMF (Document No. & paragraph)	Result - Remarks	Verdict
4.3			
4.4			
5			
6.2			
6.3			
6.4			
6.5			

9.7.7	RM RESULTS TABLE: Pressure-relief device		N/A
Clause of ISO 14971	Document Ref. in RMF (Document No. & paragraph)	Result - Remarks	Verdict
4.3			
4.4			
5			
6.2			



IEC 60601-1			
Clause	Requirement + Test	Result - Remark	Verdict
9.7.7	<b>RM RESULTS TABLE: Pressure-relief device</b>		N/A
Clause of ISO 14971	Document Ref. in RMF (Document No. & paragraph)	Result - Remarks	Verdict
6.3			
6.4			
6.5			
9.8.1	<b>RM RESULTS TABLE: Hazards associated with support systems - General</b>		N/A
Clause of ISO 14971	Document Ref. in RMF (Document No. & paragraph)	Result - Remarks	Verdict
4.2			
4.3			
4.4			
5			
6.2			
6.3			
6.4			
6.5			
9.8.2	<b>RM RESULTS TABLE: Tensile safety factor</b>		N/A
Clause of ISO 14971	Document Ref. in RMF (Document No. & paragraph)	Result - Remarks	Verdict
4.3			
4.4			
5			
6.2			
6.3			
6.4			
6.5			
9.8.3.1	<b>RM RESULTS TABLE: Strength of patient or operator support or suspension systems - General</b>		N/A
Clause of ISO 14971	Document Ref. in RMF (Document No. & paragraph)	Result - Remarks	Verdict
4.2			
4.3			
4.4			
5			
6.2			
6.3			
6.4			
6.5			



IEC 60601-1			
Clause	Requirement + Test	Result - Remark	Verdict

9.8.3.2	TABLE: PATIENT support/suspension system - Static forces			N/A
ME EQUIPMENT part or area	Position	Load	Area	Remarks
Supplementary Information:				

9.8.3.2a, b	RM RESULTS TABLE: Static forces due to loading from persons		N/A
Clause of ISO 14971	Document Ref. in RMF (Document No. & paragraph)	Result - Remarks	Verdict
4.3			
4.4			
5			
6.2			
6.3			
6.4			
6.5			

9.8.3.3	TABLE: Support/Suspension System – Dynamic forces due to loading from persons			N/A
ME EQUIPMENT part or area	Position	Safe Working Load	Area	Remarks
Supplementary Information:				

9.8.4.1	RM RESULTS TABLE: Systems with mechanical protective devices - General		N/A
Clause of ISO 14971	Document Ref. in RMF (Document No. & paragraph)	Result - Remarks	Verdict
4.3			
4.4			
5			
6.2			
6.3			

IEC 60601-1			
Clause	Requirement + Test	Result - Remark	Verdict
9.8.4.1	RM RESULTS TABLE: Systems with mechanical protective devices - General		N/A
Clause of ISO 14971	Document Ref. in RMF (Document No. & paragraph)	Result - Remarks	Verdict
6.4			
6.5			

9.8.4.3	RM RESULTS TABLE: Mechanical protective device for single activation		N/A
Clause of ISO 14971	Document Ref. in RMF (Document No. & paragraph)	Result - Remarks	Verdict
4.3			
4.4			
5			
6.2			
6.3			
6.4			
6.5			

9.8.5	RM RESULTS TABLE: Systems without mechanical protective devices		N/A
Clause of ISO 14971	Document Ref. in RMF (Document No. & paragraph)	Result - Remarks	Verdict
4.3			
4.4			
5			
6.2			
6.3			
6.4			
6.5			

10.1.1	TABLE: Measurement of X - radiation		N/A
Maximum allowable radiation pA/kg ( μSv/h) (mR/h)		36 (5 μSv/h) (0.5 mR/h)	
Surface area under test Surface no./ Description <sup>1</sup>		Measured Radiation, pA/kg (μSv/h) (mR/h)	Remarks
1/ /			
2/ /			
3/ /			
4/ /			
5/ /			
6/ /			
7/ /			

IEC 60601-1			
Clause	Requirement + Test	Result - Remark	Verdict
8/ /			
9/ /			
10/ /			

**Supplementary information:** <sup>1</sup> Measurements made at a distance of 5 cm from any surface to which OPERATOR (other than SERVICE PERSONNEL) can gain access without a TOOL, is deliberately provided with means of access, or is instructed to enter regardless of whether or not a TOOL is needed to gain access

10.1.2	RM RESULTS TABLE: ME equipment intended to produce diagnostic or therapeutic X-radiation		N/A
Clause of ISO 14971	Document Ref. in RMF (Document No. & paragraph)	Result - Remarks	Verdict
4.2			
4.3			
4.4			
5			
6.2			
6.3			
6.4			
6.5			

10.2	RM RESULTS TABLE: Alpha, beta, gamma, neutron & other particle radiation		N/A
Clause of ISO 14971	Document Ref. in RMF (Document No. & paragraph)	Result - Remarks	Verdict
4.2			
4.3			
4.4			
5			
6.2			
6.3			
6.4			
6.5			

10.3	RM RESULTS TABLE: Microwave radiation		N/A
Clause of ISO 14971	Document Ref. in RMF (Document No. & paragraph)	Result - Remarks	Verdict
4.2			
4.3			
4.4			
5			
6.2			
6.3			



IEC 60601-1			
Clause	Requirement + Test	Result - Remark	Verdict
10.3	<b>RM RESULTS TABLE: Microwave radiation</b>		N/A
Clause of ISO 14971	Document Ref. in RMF (Document No. & paragraph)	Result - Remarks	Verdict
6.4			
6.5			
10.5	<b>RM RESULTS TABLE: Other visible electromagnetic radiation</b>		N/A
Clause of ISO 14971	Document Ref. in RMF (Document No. & paragraph)	Result - Remarks	Verdict
4.2			
4.3			
4.4			
5			
6.2			
6.3			
6.4			
6.5			
10.6	<b>RM RESULTS TABLE: RISK associated with infrared radiation other than emitted by lasers and LEDs</b>		N/A
Clause of ISO 14971	Document Ref. in RMF (Document No. & paragraph)	Result - Remarks	Verdict
4.2			
4.3			
4.4			
5			
6.2			
6.3			
6.4			
6.5			
10.7	<b>RM RESULTS TABLE: Risk associated with ultraviolet radiation other than emitted by lasers and LEDs</b>		N/A
Clause of ISO 14971	Document Ref. in RMF (Document No. & paragraph)	Result - Remarks	Verdict
4.2			
4.3			
4.4			
5			
6.2			
6.3			
6.4			

IEC 60601-1			
Clause	Requirement + Test	Result - Remark	Verdict
10.7	RM RESULTS TABLE: Risk associated with ultraviolet radiation other than emitted by lasers and LEDs		N/A
Clause of ISO 14971	Document Ref. in RMF (Document No. & paragraph)	Result - Remarks	Verdict
6.5			

11.1.1	TABLE: Excessive temperatures in ME EQUIPMENT					Pass
Model No. .... :	FLIGHT 60 BLOWER	FLIGHT 60 BLOWER	FLIGHT 60 BLOWER	FLIGHT 60 BLOWER		
Test ambient (°C) . :	23.6	23.6	23.6	23.6		
Test supply voltage/frequency (V/Hz) <sup>4</sup> .....	264V/50Hz	90V/60Hz	Battery	90V/60Hz		
Test condition .....	Normal conditions	Normal conditions	Normal conditions	Blocked vents		
Model No.	Thermocouple No.	Thermocouple location <sup>3</sup>	Max allowable temperature <sup>1</sup> from Table 22, 23 or 24 or RM file for AP <sup>5</sup> (°C)		Max measured temperature <sup>2</sup> , (°C)	Remarks
Flight 60 Blower	Normal operation, Maximum load 264V/50Hz					
	1	Power Supply L3		105	39.2	88.6 (105-40+23.6)
	2	Power Supply L1		105	48.7	88.6 (105-40+23.6)
	3	Power Supply PCB near F2		130	35.7	113.6 (130-40+23.6)
	4	Power Supply T1		105	49.6	88.6 (105-40+23.6)
	5	Power Supply C17 electrolyte capacitor		85	53.7	68.6 (85-40+23.6)
	6	Power supply enclosure		70	40.1	53.6 (70-40+23.6)
	7	Power supply input power connector		85	36.2	68.6 (85-40+23.6)
	8	Power supply ambient		70	36.6	53.6 (70-40+23.6)
	9	Integral battery body		70	32.0	53.6 (70-40+23.6)
	10	Detachable battery body		70	34.6	53.6 (70-40+23.6)
	11	Mother board L1		105	51.3	88.6 (105-40+23.6)
12	Mother board L2		105	52.8	88.6 (105-40+23.6)	

IEC 60601-1				
Clause	Requirement + Test	Result - Remark		Verdict
13	Mother board C79 (E.C.)	85	47.2	68.6 (85-40+23.6)
14	Mother board PCB by U14	130	57.9	113.6 (130-40+23.6)
15	Enclosure	70	32.1	53.6 (70-40+23.6)
16	Applied part	43	23.9	26.6 (43-40+23.6)
<b>Normal operation, Maximum load 90V/60Hz</b>				
1	Power Supply L3	105	39.6	88.6 (105-40+23.6)
2	Power Supply L1	105	50.3	88.6 (105-40+23.6)
3	Power Supply PCB near F2	130	35.7	113.6 (130-40+23.6)
4	Power Supply T1	105	49.9	88.6 (105-40+23.6)
5	Power Supply C17 electrolyte capacitor	85	53.8	68.6 (85-40+23.6)
6	Power supply enclosure	70	40.7	53.6 (70-40+23.6)
7	Power supply input power connector	85	36.5	68.6 (85-40+23.6)
8	Power supply ambient	70	38.9	53.6 (70-40+23.6)
9	Integral battery body	70	33.9	53.6 (70-40+23.6)
10	Detachable battery body	70	35.2	53.6 (70-40+23.6)
11	Mother board L1	105	50.9	88.6 (105-40+23.6)
12	Mother board L2	105	52.8	88.6 (105-40+23.6)
13	Mother board C79 (E.C.)	85	46.6	68.6 (85-40+23.6)
14	Mother board PCB by U14	130	57.5	113.6 (130-40+23.6)
15	Enclosure	70	32.2	53.6 (70-40+23.6)
16	Applied part	43	23.9	26.6 (43-40+23.6)
<b>Normal operation, Maximum load Battery operated</b>				
1	Power Supply L3	105	26.2	88.6 (105-40+23.6)
2	Power Supply L1	105	26.2	88.6 (105-40+23.6)
3	Power Supply PCB near F2	130	27.1	113.6 (130-40+23.6)

IEC 60601-1				
Clause	Requirement + Test	Result - Remark		Verdict
4	Power Supply T1	105	26.1	88.6 (105-40+23.6)
5	Power Supply C17 electrolyte capacitor	85	27.3	68.6 (85-40+23.6)
6	Power supply enclosure	70	29.9	53.6 (70-40+23.6)
7	Power supply input power connector	85	27.1	68.6 (85-40+23.6)
8	Power supply ambient	70	31.4	53.6 (70-40+23.6)
9	Integral battery body	70	34.4	53.6 (70-40+23.6)
10	Detachable battery body	70	35.1	53.6 (70-40+23.6)
11	Mother board L1	105	50.0	88.6 (105-40+23.6)
12	Mother board L2	105	51.1	88.6 (105-40+23.6)
13	Mother board C79 (E.C.)	85	44.4	68.6 (85-40+23.6)
14	Mother board PCB by U14	130	52.2	113.6 (130-40+23.6)
15	Enclosure	70	29.3	53.6 (70-40+23.6)
16	Applied part	43	23.9	26.6 (43-40+23.6)
<b>Vents blocked, Maximum load 90V/60Hz</b>				
1	Power Supply L3	105	41.3	88.6 (105-40+23.6)
2	Power Supply L1	105	51.6	88.6 (105-40+23.6)
3	Power Supply PCB near F2	130	38.3	113.6 (130-40+23.6)
4	Power Supply T1	105	52.3	88.6 (105-40+23.6)
5	Power Supply C17 electrolyte capacitor	85	56.2	68.6 (85-40+23.6)
6	Power supply enclosure	70	43.0	53.6 (70-40+23.6)
7	Power supply input power connector	85	41.1	68.6 (85-40+23.6)
8	Power supply ambient	70	41.5	53.6 (70-40+23.6)
9	Integral battery body	70	36.5	53.6 (70-40+23.6)
10	Detachable battery body	70	34.5	53.6 (70-40+23.6)
11	Mother board L1	105	51.0	88.6 (105-40+23.6)

IEC 60601-1				
Clause	Requirement + Test		Result - Remark	Verdict
12	Mother board L2	105	52.1	88.6 (105-40+23.6)
13	Mother board C79 (E.C.)	85	47.8	68.6 (85-40+23.6)
14	Mother board PCB by U14	130	59.0	113.6 (130-40+23.6)
15	Enclosure	70	33.4	53.6 (70-40+23.6)
16	Applied part	43	23.9	26.6 (43-40+23.6)

**Supplementary information:**

<sup>1</sup> Maximum allowable temperature on surfaces of test corner is 90 °C

<sup>2</sup> Max temperature determined in accordance with 11.1.3e)

<sup>3</sup> When thermocouples used to determine temperature of windings, limits of Table 22 reduced by 10 °C.

<sup>4</sup> Supply voltage:

- ME EQUIPMENT with heating elements - 110 % of the maximum RATED voltage;
- Motor operated ME EQUIPMENT - least favourable voltage between 90 % of the minimum RATED and 110 % of the maximum RATED voltage. ME EQUIPMENT operated under normal load and normal DUTY CYCLE.
- Combined heating and motor operated and other ME EQUIPMENT - tested both at 110 % of the maximum RATED voltage and at 90 % of the minimum RATED voltage.

<sup>5</sup> APPLIED PARTS intended to supply heat to a PATIENT - See RISK MANAGEMENT FILE containing temperatures and clinical effects. Also, see instructions for use.

**\*Note: Maximum allowable temperature is calculated according to worst-case normal use including the maximum ambient operating temperature specified in the technical description ( $T_{max\ Ambient} = 40^{\circ}C$ ) in Remarks**

11.1.1	RM RESULTS TABLE: Maximum temperature during normal use (Table 23 or 24)		Pass
Clause of ISO 14971	Document Ref. in RMF (Document No. & paragraph)	Result - Remarks	Verdict
4.2	F60-SY-RA-SY-01-REV.I		Pass
4.3	F60-SY-RA-SY-01-REV.I		Pass
4.4	F60-SY-RA-SY-01-REV.I		Pass
5	F60-SY-RA-SY-01-REV.I		Pass
6.2	F60-SY-RA-SY-01-REV.I		Pass
6.3	F60-SY-RA-SY-01-REV.I		Pass
6.4	F60-SY-RA-SY-01-REV.I		Pass
6.5	F60-SY-RA-SY-01-REV.I		Pass

11.1.2.1	RM RESULTS TABLE: Applied parts intended to supply heat to patient		N/A
Clause of ISO 14971	Document Ref. in RMF (Document No. & paragraph)	Result - Remarks	Verdict
4.2			
4.3			
4.4			
5			

IEC 60601-1			
Clause	Requirement + Test	Result - Remark	Verdict

11.1.2.1	RM RESULTS TABLE: Applied parts intended to supply heat to patient		N/A
Clause of ISO 14971	Document Ref. in RMF (Document No. & paragraph)	Result - Remarks	Verdict
6.2			
6.3			
6.4			
6.5			

11.1.2.2	RM RESULTS TABLE: Applied parts not intended to supply heat to patient		N/A
Clause of ISO 14971	Document Ref. in RMF (Document No. & paragraph)	Result - Remarks	Verdict
4.2			
4.3			
4.4			
5			
6.2			
6.3			
6.4			
6.5			

11.1.3	TABLE: Temperature of windings by change-of-resistance method							N/A
Temperature T of winding:	t <sub>1</sub> (°C)	R <sub>1</sub> (Ω)	t <sub>2</sub> (°C)	R <sub>2</sub> (Ω)	T (°C)	Allowed T <sub>max</sub> (°C)	Insulation class	

Supplementary information:

11.1.3	RM RESULTS TABLE: Measurements		N/A
Clause of ISO 14971	Document Ref. in RMF (Document No. & paragraph)	Result - Remarks	Verdict
4.2			
4.3			
4.4			
5			
6.2			
6.3			



IEC 60601-1			
Clause	Requirement + Test	Result - Remark	Verdict
11.1.3	RM RESULTS TABLE: Measurements		N/A
Clause of ISO 14971	Document Ref. in RMF (Document No. & paragraph)	Result - Remarks	Verdict
6.4			
6.5			

11.2.2.1 RM RESULTS TABLE: Risk of fire in an oxygen rich environment			
Clause of ISO 14971	Document Ref. in RMF (Document No. & paragraph)	Result - Remarks	Verdict
4.2			
4.3			
4.4			
5			
6.2			
6.3			
6.4			
6.5			

11.2.2.1 TABLE: Alternative method to 11.2.2.1 a) 5) to determine existence of an ignition source			N/A
Areas where sparking might cause ignition:		Remarks	
1.			
2.			
3.			
5.			
6.			
Materials of the parts between which sparks could occur (Composition, Grade Designation, Manufacturer):		Remarks	
1.			
2.			
3.			
4.			
5.			
6.			
Test parameters selected representing worst case conditions for ME EQUIPMENT:		Remarks	



IEC 60601-1			
Clause	Requirement + Test	Result - Remark	Verdict
	Oxygen concentration (%):		
	Fuel		
	Current (A)		
	Voltage (V)		
	Capacitance ( $\mu$ F)		
	Inductance or resistance (h or $\Omega$ ):		
	No. of trials (300 Min)		
	Sparks resulted in ignition (Yes/No):		
<b>Supplementary information:</b>			
Test procedure of 11.2.2.1 a) 5) & Figs 35-37 used for tests. For circuits not in Figs 35-37, test voltage or current set at 3 times the worst case values with other parameters set at worst case values to determine if ignition can occur.			

11.3	RM RESULTS TABLE: Constructional requirements for fire enclosures of ME equipment		Pass
Clause of ISO 14971	Document Ref. in RMF (Document No. & paragraph)	Result - Remarks	Verdict
4.2	F60-SY-RA-SY-01-REV.I		Pass
4.3	F60-SY-RA-SY-01-REV.I		Pass
4.4	F60-SY-RA-SY-01-REV.I		Pass
5	F60-SY-RA-SY-01-REV.I		Pass
6.2	F60-SY-RA-SY-01-REV.I		Pass
6.3	F60-SY-RA-SY-01-REV.I		Pass
6.4	F60-SY-RA-SY-01-REV.I		Pass
6.5	F60-SY-RA-SY-01-REV.I		Pass

11.5	RM RESULTS TABLE: ME equipment and ME systems intended for use in conjunction with flammable agents		N/A
Clause of ISO 14971	Document Ref. in RMF (Document No. & paragraph)	Result - Remarks	Verdict
4.2			
4.3			
4.4			
5			
6.2			
6.3			
6.4			
6.5			

IEC 60601-1			
Clause	Requirement + Test	Result - Remark	Verdict
11.6.1	<b>TABLE: overflow, spillage, leakage, ingress of water, cleaning, disinfection, sterilization, compatibility with substances</b>		P
Clause / Test Name	Test Condition	Part under test	Remarks
11.6.6 Cleaning and disinfection	Evaluated according to method of cleaning mentioned in instructions for use	Whole unit	
<b>Supplementary information:</b>			

11.6.2	<b>RM RESULTS TABLE: Overflow in ME equipment</b>		N/A
Clause of ISO 14971	Document Ref. in RMF (Document No. & paragraph)	Result - Remarks	Verdict
4.2			
4.3			
4.4			
5			

11.6.3	<b>RM RESULTS TABLE: Spillage on ME equipment and ME system</b>		Pass
Clause of ISO 14971	Document Ref. in RMF (Document No. & paragraph)	Result - Remarks	Verdict
4.2	F60-SY-RA-SY-01-REV.I		Pass
4.3	F60-SY-RA-SY-01-REV.I		Pass
4.4	F60-SY-RA-SY-01-REV.I		Pass
5	F60-SY-RA-SY-01-REV.I		Pass
6.2	F60-SY-RA-SY-01-REV.I		Pass
6.3	F60-SY-RA-SY-01-REV.I		Pass
6.4	F60-SY-RA-SY-01-REV.I		Pass
6.5	F60-SY-RA-SY-01-REV.I		Pass

11.6.5	<b>RM RESULTS TABLE: Ingress of water or particulate matter into ME EQUIPMENT and ME SYSTEMS</b>		N/A
Clause of ISO 14971	Document Ref. in RMF (Document No. & paragraph)	Result - Remarks	Verdict
4.2			
4.3			
4.4			
5			

IEC 60601-1			
Clause	Requirement + Test	Result - Remark	Verdict

11.6.6 RM RESULTS TABLE: Cleaning and disinfection of ME equipment and ME systems			
Clause of ISO 14971	Document Ref. in RMF (Document No. & paragraph)	Result - Remarks	Verdict
4.2	F60-SY-RA-SY-01-REV.I		Pass
4.3	F60-SY-RA-SY-01-REV.I		Pass
4.4	F60-SY-RA-SY-01-REV.I		Pass
5	F60-SY-RA-SY-01-REV.I		Pass
6.2	F60-SY-RA-SY-01-REV.I		Pass
6.3	F60-SY-RA-SY-01-REV.I		Pass
6.4	F60-SY-RA-SY-01-REV.I		Pass
6.5	F60-SY-RA-SY-01-REV.I		Pass

11.6.7 RM RESULTS TABLE: Sterilization of ME equipment and ME systems			
Clause of ISO 14971	Document Ref. in RMF (Document No. & paragraph)	Result - Remarks	Verdict
4.2			
4.3			
4.4			
5			
6.2			
6.3			
6.4			
6.5			

11.6.8 RM RESULTS TABLE: Compatibility with substances used			
Clause of ISO 14971	Document Ref. in RMF (Document No. & paragraph)	Result - Remarks	Verdict
4.2			
4.3			
4.4			
5			
6.2			
6.3			
6.4			
6.5			

12.1 RM RESULTS TABLE: Accuracy of controls and equipment			
Clause of ISO 14971	Document Ref. in RMF (Document No. & paragraph)	Result - Remarks	Verdict
			Pass

IEC 60601-1			
Clause	Requirement + Test	Result - Remark	Verdict
12.1	<b>RM RESULTS TABLE: Accuracy of controls and equipment</b>		Pass
Clause of ISO 14971	Document Ref. in RMF (Document No. & paragraph)	Result - Remarks	Verdict
4.2	F60-SY-RA-SY-01-REV.I		Pass
4.3	F60-SY-RA-SY-01-REV.I		Pass
4.4	F60-SY-RA-SY-01-REV.I		Pass
5	F60-SY-RA-SY-01-REV.I		Pass
6.2	F60-SY-RA-SY-01-REV.I		Pass
6.3	F60-SY-RA-SY-01-REV.I		Pass
6.4	F60-SY-RA-SY-01-REV.I		Pass
6.5	F60-SY-RA-SY-01-REV.I		Pass

12.3	<b>RM RESULTS TABLE: Alarm systems</b>		Pass
Clause of ISO 14971	Document Ref. in RMF (Document No. & paragraph)	Result - Remarks	Verdict
4.2	F60-SY-RA-SY-01-REV.I		Pass
4.3	F60-SY-RA-SY-01-REV.I		Pass
4.4	F60-SY-RA-SY-01-REV.I		Pass
5	F60-SY-RA-SY-01-REV.I		Pass
6.2	F60-SY-RA-SY-01-REV.I		Pass
6.3	F60-SY-RA-SY-01-REV.I		Pass
6.4	F60-SY-RA-SY-01-REV.I		Pass
6.5	F60-SY-RA-SY-01-REV.I		Pass

12.4.1	<b>RM RESULTS TABLE: Intentional exceeding of safety limits</b>		Pass
Clause of ISO 14971	Document Ref. in RMF (Document No. & paragraph)	Result - Remarks	Verdict
4.2	F60-SY-RA-SY-01-REV.I		Pass
4.3	F60-SY-RA-SY-01-REV.I		Pass
4.4	F60-SY-RA-SY-01-REV.I		Pass
5	F60-SY-RA-SY-01-REV.I		Pass
6.2	F60-SY-RA-SY-01-REV.I		Pass
6.3	F60-SY-RA-SY-01-REV.I		Pass
6.4	F60-SY-RA-SY-01-REV.I		Pass
6.5	F60-SY-RA-SY-01-REV.I		Pass

12.4.2	<b>RM RESULTS TABLE: Indication of parameters relevant to safety</b>		Pass
Clause of ISO 14971	Document Ref. in RMF (Document No. & paragraph)	Result - Remarks	Verdict
4.2	F60-SY-RA-SY-01-REV.I		Pass
4.3	F60-SY-RA-SY-01-REV.I		Pass

IEC 60601-1			
Clause	Requirement + Test	Result - Remark	Verdict
12.4.2	RM RESULTS TABLE: Indication of parameters relevant to safety		Pass
Clause of ISO 14971	Document Ref. in RMF (Document No. & paragraph)	Result - Remarks	Verdict
4.4	F60-SY-RA-SY-01-REV.I		Pass
5	F60-SY-RA-SY-01-REV.I		Pass
6.2	F60-SY-RA-SY-01-REV.I		Pass
6.3	F60-SY-RA-SY-01-REV.I		Pass
6.4	F60-SY-RA-SY-01-REV.I		Pass
6.5	F60-SY-RA-SY-01-REV.I		Pass
12.4.3	RM RESULTS TABLE: Accidental selection of excessive output values		Pass
Clause of ISO 14971	Document Ref. in RMF (Document No. & paragraph)	Result - Remarks	Verdict
4.2	F60-SY-RA-SY-01-REV.I		Pass
4.3	F60-SY-RA-SY-01-REV.I		Pass
4.4	F60-SY-RA-SY-01-REV.I		Pass
5	F60-SY-RA-SY-01-REV.I		Pass
6.2	F60-SY-RA-SY-01-REV.I		Pass
6.3	F60-SY-RA-SY-01-REV.I		Pass
6.4	F60-SY-RA-SY-01-REV.I		Pass
6.5	F60-SY-RA-SY-01-REV.I		Pass
12.4.4	RM RESULTS TABLE: Incorrect output		Pass
Clause of ISO 14971	Document Ref. in RMF (Document No. & paragraph)	Result - Remarks	Verdict
4.2	F60-SY-RA-SY-01-REV.I		Pass
4.3	F60-SY-RA-SY-01-REV.I		Pass
4.4	F60-SY-RA-SY-01-REV.I		Pass
5	F60-SY-RA-SY-01-REV.I		Pass
6.2	F60-SY-RA-SY-01-REV.I		Pass
6.3	F60-SY-RA-SY-01-REV.I		Pass
6.4	F60-SY-RA-SY-01-REV.I		Pass
6.5	F60-SY-RA-SY-01-REV.I		Pass
12.4.5.2	RM RESULTS TABLE: Diagnostic X-ray equipment		N/A
Clause of ISO 14971	Document Ref. in RMF (Document No. & paragraph)	Result - Remarks	Verdict
4.2			
4.3			
4.4			
5			

IEC 60601-1			
Clause	Requirement + Test	Result - Remark	Verdict
12.4.5.2	<b>RM RESULTS TABLE: Diagnostic X-ray equipment</b>		N/A
Clause of ISO 14971	Document Ref. in RMF (Document No. & paragraph)	Result - Remarks	Verdict
6.2			
6.3			
6.4			
6.5			
12.4.5.3	<b>RM RESULTS TABLE: Radiotherapy equipment</b>		N/A
Clause of ISO 14971	Document Ref. in RMF (Document No. & paragraph)	Result - Remarks	Verdict
4.2			
4.3			
4.4			
5			
6.2			
6.3			
6.4			
6.5			
12.4.5.4	<b>RM RESULTS TABLE: Other ME equipment producing diagnostic or therapeutic radiation</b>		N/A
Clause of ISO 14971	Document Ref. in RMF (Document No. & paragraph)	Result - Remarks	Verdict
4.2			
4.3			
4.4			
5			
6.2			
6.3			
6.4			
6.5			
12.4.6	<b>RM RESULTS TABLE: Diagnostic or therapeutic acoustic pressure</b>		N/A
Clause of ISO 14971	Document Ref. in RMF (Document No. & paragraph)	Result - Remarks	Verdict
4.2			
4.3			
4.4			
5			
6.2			
6.3			

IEC 60601-1			
Clause	Requirement + Test	Result - Remark	Verdict
12.4.6	<b>RM RESULTS TABLE: Diagnostic or therapeutic acoustic pressure</b>		N/A
Clause of ISO 14971	Document Ref. in RMF (Document No. & paragraph)	Result - Remarks	Verdict
6.4			
6.5			

13.1.2	<b>TABLE: measurement of power or energy dissipation in parts &amp; components to waive SINGLE FAULT CONDITIONS in 4.7, 8.1 b), 8.7.2, and 13.2.2 relative to emission of flames, molten metal, or ignitable substances</b>			N/A
Power dissipated less than (W) .....		15		
Energy dissipated less than (J) .....		900		
Part or component tested	Measured power dissipated (W)	Calculated energy dissipated (J)	SINGLE FAULT CONDITIONS waived (Yes/No)	Remarks
<b>Supplementary information:</b>				

13.2	<b>TABLE: SINGLE FAULT CONDITIONS in accordance with 13.2.2 to 13.2.13, inclusive</b>			P
Clause No.	Description of SINGLE FAULT CONDITION	Results observed	HAZARDOUS SITUATION (Yes/No)	
13.2.2	<b>Electrical SINGLE FAULT CONDITIONS per Clause 8.1:</b>	—	—	
	Booster card (21.5Vdc power to Blower ) S.C D2 Tested while EUT on Standby Mode	EUT continue STANDBY MODE. Main Red fault indication starts blinking, Fault led lighted Red, Screen displayed "Motor Fault", and audio beep alarm activated. PCB max Temp 75.2°C , Coil max Temp 107.1°C, ambient 22.3°C After removing short EUT returned to normal operation Duration 1h No Hazard No Fire	No	

IEC 60601-1			
Clause	Requirement + Test	Result - Remark	Verdict
Clause No.	Description of SINGLE FAULT CONDITION	Results observed	HAZARDOUS SITUATION (Yes/No)
	Booster card (21.5Vdc power to Blower ) S.C D2 Tested while EUT on Treatment Mode	Ventilation immediately stopped. Main Red fault indication starts blinking, Fault led lighted Red, Screen displayed "Motor Fault", and audio beep alarm activated. PCB max Temp 31.2°C , Coil max Temp 32.1°C, ambient 22.3°C After removing short EUT returned to normal operation Duration 1h No Hazard No Fire	No
	Detachable Battery pack contacts +/- (14.8Vdc) S.C.	Battery protection Immediately activated, EUT continue operation, Main Red fault indication starts blinking, Fault led lighted Red, Screen displayed "MainBat.Gauge", and audio beep alarm activated. After removing the short EUT returned to normal operation, Max battery Temp 24.6°C, Ambient 23.6°C, Duration 1h No hazard no fire	No
	Over Charge Detachable Battery , charging when battery was empty	EUT continue normal operation, Max battery temperature 35.2°C, Ambient 23.6°C, Duration 7h No hazard no fire	No
	Integral Battery pack contacts +/- (14.8Vdc) S.C	Battery protection Immediately activated, EUT continue operation, Main Red fault indication starts blinking, Fault led lighted Red, Screen displayed "SEcBat.Gauge", and audio beep alarm activated. After removing the short EUT returned to normal operation, Max battery Temp 24.6°C, Ambient 23.6°C, Duration 1h No hazard no fire	No
	Over Charge Integral Battery , charging when battery was empty	EUT continue normal operation, Max battery temperature 34.4°C, Ambient 23.6°C, Duration 7h No hazard no fire	No

IEC 60601-1			
Clause	Requirement + Test	Result - Remark	Verdict
Clause No.	Description of SINGLE FAULT CONDITION	Results observed	HAZARDOUS SITUATION (Yes/No)
	Oxygen leakage sensor Disconnect sensor blow wire	EUT continue normal operation for 30sec than Red fault indication starts blinking, Fault led lighted Red,, audio beep alarm activated Screen displayed ambient O2 alarm, O2 input shutdown Ambient 23.7°C Duration 30min No Hazard No Fire,	No
	Oxygen delivery sensor Disconnect sensor blow wire	EUT continue normal operation for 30sec than Red fault indication starts blinking, Fault led lighted Red,, audio beep alarm activated Screen displayed ambient O2 alarm, O2 input shutdown Ambient 23.7 °C Duration 30min No Hazard No Fire,	No
<b>13.2.3</b>	<b>Overheating of transformers per Clause 15.5:</b>	—	—
<b>13.2.4</b>	<b>Failure of THERMOSTATS according to 13.2.13 &amp; 15.4.2, overloading - THERMOSTATS short circuited or interrupted, the less favourable of the two:</b>	—	—
	Blower temperature sensor ,wire Disconnected	EUT continue normal operation, Main Red fault indication starts blinking, Fault led lighted Red, Screen displayed "Check motor Temp sensor". and audio beep alarm activated. Duration 30min No fire no hazard	No
	Blower temperature sensor ,S.C	Ventilation immediately stopped. Main Red fault indication starts blinking, Fault led lighted Red, Screen displayed "Motor Fault", and audio beep alarm activated. Duration 30min No Hazard No Fire	No
<b>13.2.5</b>	<b>Failure of temperature limiting devices according to 13.2.13 &amp; 15.4.2, overloading, THERMOSTATS short circuited or interrupted, the less favourable of the two:</b>	—	—

IEC 60601-1			
Clause	Requirement + Test	Result - Remark	Verdict
Clause No.	Description of SINGLE FAULT CONDITION	Results observed	HAZARDOUS SITUATION (Yes/No)
13.2.6	Leakage of liquid - RISK MANAGEMENT FILE examined to determine the appropriate test conditions (sealed rechargeable batteries exempted)	—	—
13.2.7	Impairment of cooling that could result in a HAZARD using test method of 11.1:	—	—
	Ventilation openings on top and sides impaired by covering openings on top of ENCLOSURE or positioning of ME EQUIPMENT against walls	EUT continue normal operation , Max measured temperatures :Power Supply C17: 56.2°C, Mother board PCB near U14: 59.0°C, Ambient :23.6°C Duration :2h No overheating, no fire.	NO
13.2.8	Locking of moving parts – Only one part locked at a time – Also see 13.2.10 below:	—	—
	Blower motor locked	Ventilation immediately stopped. Main Red fault indication starts blinking, Fault led lighted Red, Screen displayed “Motor Fault”, and audio beep alarm activated. Max measured temperature on Blower 24°C, Ambient 23.7 Duration 30min No Hazard No Fire	NO
13.2.9	Interruption and short circuiting of motor capacitors – Motor capacitors short & open circuited <sup>1</sup> – Also see 13.10	—	—
		V measured =	
		V measured =	
13.2.10	Additional test criteria for motor operated ME EQUIPMENT in 13.2.8 & 13.2.9:	—	—



IEC 60601-1			
Clause	Requirement + Test	Result - Remark	Verdict

Clause No.	Description of SINGLE FAULT CONDITION	Results observed	HAZARDOUS SITUATION (Yes/No)
	For every test in SINGLE FAULT CONDITION of 13.2.8 and 13.2.9, motor-operated EQUIPMENT started from COLD CONDITION at RATED voltage or at the upper limit of RATED voltage range for specified time:		
	Temperatures of windings determined at the end of specified test periods or at the instant of operation of fuses, THERMAL CUT-OUTS, motor protective devices		
	Temperatures measured as specified in 11.1.3 d)		
	Temperatures did not exceed limits of Table 26		
13.2.11	Failures of components in ME EQUIPMENT used in conjunction with OXYGEN RICH ENVIRONMENTS:	—	—
13.2.12	Failure of parts that might result in a MECHANICAL HAZARD (See 9 & 15.3):	—	—

**Supplementary information:**

<sup>1</sup> Test with short-circuited capacitor not performed when motor provided with a capacitor complying with IEC 60252-1 and the ME EQUIPMENT not intended for unattended use including automatic or remote control. See Attachment # and appended Table 8.10.

13.2.6	RM RESULTS TABLE: Leakage of liquid		N/A
Clause of ISO 14971	Document Ref. in RMF (Document No. & paragraph)	Result - Remarks	Verdict
4.2			
4.3			
4.4			
5			
6.2			
6.3			
6.4			
6.5			

14.1	RM RESULTS TABLE: Programmable electrical medical systems - General	Pass
------	---	------

IEC 60601-1			
Clause	Requirement + Test	Result - Remark	Verdict
Clause of ISO 14971	Document Ref. in RMF (Document No. & paragraph)	Result - Remarks	Verdict
4.2	F60-SY-RA-SY-01-REV.I		Pass
4.3	F60-SY-RA-SY-01-REV.I		Pass
4.4	F60-SY-RA-SY-01-REV.I		Pass
5	F60-SY-RA-SY-01-REV.I		Pass
14.6.1	RM RESULTS TABLE: Identification of known and foreseeable hazards		Pass
Clause of ISO 14971	Document Ref. in RMF (Document No. & paragraph)	Result - Remarks	Verdict
4.3	F60-SY-RA-SY-01-REV.I		Pass
14.6.2	RM RESULTS TABLE: Risk control		Pass
Clause of ISO 14971	Document Ref. in RMF (Document No. & paragraph)	Result - Remarks	Verdict
6.1	F60-SY-RA-SY-01-REV.I		Pass
14.7	RM RESULTS TABLE: Requirement specification		Pass
Clause of ISO 14971	Document Ref. in RMF (Document No. & paragraph)	Result - Remarks	Verdict
6.3	F60-SY-RA-SY-01-REV.I		Pass
14.8	RM RESULTS TABLE: Architecture		Pass
Clause of ISO 14971	Document Ref. in RMF (Document No. & paragraph)	Result - Remarks	Verdict
6.3	F60-SY-RA-SY-01-REV.I		Pass
14.9	RM RESULTS TABLE: Design and Implementation		Pass
Clause of ISO 14971	Document Ref. in RMF (Document No. & paragraph)	Result - Remarks	Verdict
6.2	F60-SY-RA-SY-01-REV.I		Pass
6.3	F60-SY-RA-SY-01-REV.I		Pass
14.10	RM RESULTS TABLE: Verification		Pass
Clause of ISO 14971	Document Ref. in RMF (Document No. & paragraph)	Result - Remarks	Verdict
6.3	F60-SY-RA-SY-01-REV.I		Pass
14.11	RM RESULTS TABLE: PEMS validation		Pass
Clause of ISO 14971	Document Ref. in RMF (Document No. & paragraph)	Result - Remarks	Verdict
6.3	F60-SY-RA-SY-01-REV.I		Pass



IEC 60601-1			
Clause	Requirement + Test	Result - Remark	Verdict

14.13	RM RESULTS TABLE: Connection of PEMS by NETWORK/DATA COUPLING to other equipment		Pass
Clause of ISO 14971	Document Ref. in RMF (Document No. & paragraph)	Result - Remarks	Verdict
4.2	F60-SY-RA-SY-01-REV.I		Pass
4.3	F60-SY-RA-SY-01-REV.I		Pass
4.4	F60-SY-RA-SY-01-REV.I		Pass
5	F60-SY-RA-SY-01-REV.I		Pass
6.2	F60-SY-RA-SY-01-REV.I		Pass
6.3	F60-SY-RA-SY-01-REV.I		Pass

15.1	RM RESULTS TABLE: Construction of ME equipment – Arrangements of controls and indicators of ME equipment		Pass
Clause of ISO 14971	Document Ref. in RMF (Document No. & paragraph)	Result - Remarks	Verdict
4.2	F60-SY-RA-SY-01-REV.I		Pass
4.3	F60-SY-RA-SY-01-REV.I		Pass
4.4	F60-SY-RA-SY-01-REV.I		Pass
5	F60-SY-RA-SY-01-REV.I		Pass
6.2	F60-SY-RA-SY-01-REV.I		Pass
6.3	F60-SY-RA-SY-01-REV.I		Pass
6.4	F60-SY-RA-SY-01-REV.I		Pass
6.5	F60-SY-RA-SY-01-REV.I		Pass

15.3	TABLE: Mechanical Strength tests <sup>1)</sup>		Pass
Clause	Name of Test	Test conditions	Observed results/Remarks
15.3.2	Push Test	Force = 250 N ± 10 N for 5 s	No adverse effect
15.3.3	Impact Test	Steel ball (50 mm in dia., 500 g ± 25 g) falling from a 1.3 m	No adverse effect
15.3.4.1	Drop Test (hand-held)	Free fall height (m) = 1m	N/A
15.3.4.2	Drop Test (portable)	Drop height (cm) = 5	No adverse effect
15.3.5	Rough handling test	Travel speed (m/s) =	N/A
15.3.6	Mould Stress Relief	7 h in oven at temperature (°C) =	No adverse effect

Supplementary information: <sup>1)</sup>As applicable, Push, Impact, Drop, Mould Stress Relief and Rough Handling Tests (delete not applicable rows).

IEC 60601-1			
Clause	Requirement + Test	Result - Remark	Verdict
15.3.2	<b>RM RESULTS TABLE: Push test</b>		Pass
Clause of ISO 14971	Document Ref. in RMF (Document No. & paragraph)	Result - Remarks	Verdict
4.2	F60-SY-RA-SY-01-REV.I		Pass
4.3	F60-SY-RA-SY-01-REV.I		Pass
4.4	F60-SY-RA-SY-01-REV.I		Pass
5	F60-SY-RA-SY-01-REV.I		Pass
15.3.3	<b>RM RESULTS TABLE: Impact test</b>		Pass
Clause of ISO 14971	Document Ref. in RMF (Document No. & paragraph)	Result - Remarks	Verdict
4.2	F60-SY-RA-SY-01-REV.I		Pass
4.3	F60-SY-RA-SY-01-REV.I		Pass
4.4	F60-SY-RA-SY-01-REV.I		Pass
5	F60-SY-RA-SY-01-REV.I		Pass
15.3.4.2	<b>RM RESULTS TABLE: Portable ME equipment</b>		Pass
Clause of ISO 14971	Document Ref. in RMF (Document No. & paragraph)	Result - Remarks	Verdict
4.2	F60-SY-RA-SY-01-REV.I		Pass
4.3	F60-SY-RA-SY-01-REV.I		Pass
4.4	F60-SY-RA-SY-01-REV.I		Pass
5	F60-SY-RA-SY-01-REV.I		Pass
15.3.5	<b>RM RESULTS TABLE: Rough handling test</b>		N/A
Clause of ISO 14971	Document Ref. in RMF (Document No. & paragraph)	Result - Remarks	Verdict
4.2			
4.3			
4.4			
5			
15.4.1	<b>RM RESULTS TABLE: Construction of connectors</b>		Pass
Clause of ISO 14971	Document Ref. in RMF (Document No. & paragraph)	Result - Remarks	Verdict
4.2	F60-SY-RA-SY-01-REV.I		Pass
4.3	F60-SY-RA-SY-01-REV.I		Pass
4.4	F60-SY-RA-SY-01-REV.I		Pass
5	F60-SY-RA-SY-01-REV.I		Pass
6.2	F60-SY-RA-SY-01-REV.I		Pass
6.3	F60-SY-RA-SY-01-REV.I		Pass
6.4	F60-SY-RA-SY-01-REV.I		Pass

IEC 60601-1			
Clause	Requirement + Test	Result - Remark	Verdict
15.4.1	<b>RM RESULTS TABLE: Construction of connectors</b>		Pass
Clause of ISO 14971	Document Ref. in RMF (Document No. & paragraph)	Result - Remarks	Verdict
6.5	F60-SY-RA-SY-01-REV.I		Pass
15.4.2.1 a	<b>RM RESULTS TABLE: THERMAL CUT-OUTS and OVER-CURRENT RELEASES</b>		N/A
Clause of ISO 14971	Document Ref. in RMF (Document No. & paragraph)	Result - Remarks	Verdict
4.2			
4.3			
4.4			
5			
15.4.2.1 b	<b>RM RESULTS TABLE: THERMAL CUT-OUTS with a safety function</b>		N/A
Clause of ISO 14971	Document Ref. in RMF (Document No. & paragraph)	Result - Remarks	Verdict
4.2			
4.3			
4.4			
15.4.2.1 c	<b>RM RESULTS TABLE: Independent non-SELF-RESETTING THERMAL CUT-OUT</b>		N/A
Clause of ISO 14971	Document Ref. in RMF (Document No. & paragraph)	Result - Remarks	Verdict
4.2			
4.3			
4.4			
15.4.2.1 d	<b>RM RESULTS TABLE: Loss of function of ME EQUIPMENT</b>		N/A
Clause of ISO 14971	Document Ref. in RMF (Document No. & paragraph)	Result - Remarks	Verdict
4.2			
4.3			
4.4			
15.4.2.1 h	<b>RM RESULTS TABLE: ME EQUIPMENT with tubular heating elements</b>		N/A
Clause of ISO 14971	Document Ref. in RMF (Document No. & paragraph)	Result - Remarks	Verdict
4.2			
4.3			
4.4			
15.4.3.1	<b>RM RESULTS TABLE: Housing</b>		Pass

IEC 60601-1			
Clause	Requirement + Test	Result - Remark	Verdict
<b>Clause of ISO 14971</b>	<b>Document Ref. in RMF (Document No. &amp; paragraph)</b>	<b>Result - Remarks</b>	<b>Verdict</b>
4.2	F60-SY-RA-SY-01-REV.I		Pass
4.3	F60-SY-RA-SY-01-REV.I		Pass
4.4	F60-SY-RA-SY-01-REV.I		Pass
<b>15.4.3.2</b>	<b>RM RESULTS TABLE: Connection</b>		<b>Pass</b>
<b>Clause of ISO 14971</b>	<b>Document Ref. in RMF (Document No. &amp; paragraph)</b>	<b>Result - Remarks</b>	<b>Verdict</b>
4.2	F60-SY-RA-SY-01-REV.I		Pass
4.3	F60-SY-RA-SY-01-REV.I		Pass
4.4	F60-SY-RA-SY-01-REV.I		Pass
<b>15.4.3.3</b>	<b>RM RESULTS TABLE: Protection against overcharging</b>		<b>Pass</b>
<b>Clause of ISO 14971</b>	<b>Document Ref. in RMF (Document No. &amp; paragraph)</b>	<b>Result - Remarks</b>	<b>Verdict</b>
4.2	F60-SY-RA-SY-01-REV.I		Pass
4.3	F60-SY-RA-SY-01-REV.I		Pass
4.4	F60-SY-RA-SY-01-REV.I		Pass
<b>15.4.3.4</b>	<b>RM RESULTS TABLE: Lithium batteries</b>		<b>Pass</b>
<b>Clause of ISO 14971</b>	<b>Document Ref. in RMF (Document No. &amp; paragraph)</b>	<b>Result - Remarks</b>	<b>Verdict</b>
4.2	F60-SY-RA-SY-01-REV.I		Pass
4.3	F60-SY-RA-SY-01-REV.I		Pass
4.4	F60-SY-RA-SY-01-REV.I		Pass
<b>15.4.3.5</b>	<b>RM RESULTS TABLE: Excessive current and voltage protection</b>		<b>Pass</b>
<b>Clause of ISO 14971</b>	<b>Document Ref. in RMF (Document No. &amp; paragraph)</b>	<b>Result - Remarks</b>	<b>Verdict</b>
4.2	F60-SY-RA-SY-01-REV.I		Pass
4.3	F60-SY-RA-SY-01-REV.I		Pass
4.4	F60-SY-RA-SY-01-REV.I		Pass
5	F60-SY-RA-SY-01-REV.I		Pass
6.2	F60-SY-RA-SY-01-REV.I		Pass
6.3	F60-SY-RA-SY-01-REV.I		Pass
6.4	F60-SY-RA-SY-01-REV.I		Pass
6.5	F60-SY-RA-SY-01-REV.I		Pass
<b>15.4.4</b>	<b>RM RESULTS TABLE: Indicators</b>		<b>Pass</b>
<b>Clause of ISO 14971</b>	<b>Document Ref. in RMF (Document No. &amp; paragraph)</b>	<b>Result - Remarks</b>	<b>Verdict</b>

IEC 60601-1			
Clause	Requirement + Test	Result - Remark	Verdict

15.4.4	RM RESULTS TABLE: Indicators		Pass
Clause of ISO 14971	Document Ref. in RMF (Document No. & paragraph)	Result - Remarks	Verdict
4.2	F60-SY-RA-SY-01-REV.I		Pass
4.3	F60-SY-RA-SY-01-REV.I		Pass
4.4	F60-SY-RA-SY-01-REV.I		Pass

15.4.5	RM RESULTS TABLE: Pre-set controls		N/A
Clause of ISO 14971	Document Ref. in RMF (Document No. & paragraph)	Result - Remarks	Verdict
4.2			
4.3			
4.4			
5			
6.2			
6.3			
6.4			
6.5			

15.4.6	TABLE: actuating parts of controls of ME EQUIPMENT – torque & axial pull tests					N/A
Rotating control under test	Gripping diameter “d” of control knob (mm) <sup>1</sup>	Torque from Table 30 (Nm)	Axial force applied (N)	Unacceptable RISK occurred Yes/No	Remarks	

**Supplementary information:** <sup>1</sup> Gripping diameter (d) is the maximum width of a control knob regardless of its shape (e.g. control knob with pointer)

15.4.7.3 b	RM RESULTS TABLE: Entry of liquids		N/A
Clause of ISO 14971	Document Ref. in RMF (Document No. & paragraph)	Result - Remarks	Verdict
4.2			
4.3			
4.4			

IEC 60601-1							
Clause	Requirement + Test				Result - Remark		Verdict
15.5.1.2	<b>TABLE: transformer short circuit test short-circuit applied at end of windings or at the first point that could be short circuited under SINGLE FAULT CONDITION</b>						N/A
Primary voltage (most adverse value from 90 % to 110 % of RATED voltage)(V) <sup>1</sup> .... :							—
RATED input frequency (Hz)..... :							—
Winding tested	Class of insulation (A, B, E, F, or H)	Type of protective device (fuse, circuit breaker) /Ratings	Protective device operated Yes/No	Time to THERMAL STABILITY (when protective device did not operate)(Min)	Maximum allowed temp from Table 31 (°C)	Maximum winding temp measured (°C)	Ambient (°C)
<b>Supplementary information:</b>							
<sup>1</sup> Loads on other windings between no load and their NORMAL USE load. Short-circuit applied at end of windings or at the first point that could be short circuited under SINGLE FAULT CONDITION.							

15.5.1.3	<b>TABLE: transformer overload test – conducted only when protective device under short-circuit test operated</b>						N/A
Primary voltage, most adverse value between 90 % to 110 % of RATED voltage (V) <sup>1</sup> .. :							
RATED input frequency (Hz)..... :							
Test current just below minimum current that would activate protective device & achieve THERMAL STABILITY under method a) (A)..... :							
Test current based on Table 32 when protective device that operated under method a) is external to transformer, and it was shunted (A) .....							
Winding tested	Class of insulation (A, B, E, F, H)	Type of protective device used (fuse, circuit breaker)/Ratings	Maximum allowed temp from Table 31 (°C)	Maximum winding temp measured (°C)	Ambient (°C)		
<b>Supplementary information:</b>							
<sup>1</sup> Loads on other windings between no load and their NORMAL USE load.							
Time durations: - IEC 60127-1 fuse: 30 min at current from Table 32.							
Non IEC 60127-1 fuse: 30 min at the current based on characteristics supplied by fuse manufacturer, specifically, 30 min clearing-time current. When no 30 min clearing-time current data available, test current from Table 32 used until THERMAL STABILITY achieved.							
- Other types of protective devices: until THERMAL STABILITY achieved at a current just below minimum current operating the protective device in a). This portion concluded at specified time or when a second protective device opened.							

IEC 60601-1					
Clause	Requirement + Test			Result - Remark	Verdict
15.5.2	TABLE: Transformer dielectric strength after humidity preconditioning of 5.7				N/A
Transformer Model/Type/ Part No	Test voltage applied between	Test voltage, (V)	Test frequency (Hz)	Breakdown Yes/No	Deterioration Yes/No
<b>Supplementary information:</b> Tests conducted under the conditions of 11.1, in ME EQUIPMENT or under simulated conditions on the bench. See Clause 15.5.2 for test parameters & other details					

16.1	RM RESULTS TABLE: General requirements for ME Systems			N/A
Clause of ISO 14971	Document Ref. in RMF (Document No. & paragraph)	Result - Remarks		Verdict
4.2				
4.3				
4.4				
5				

16.6.1	TABLE: LEAKAGE CURRENTS in ME SYSTEM _ TOUCH CURRENT MEASUREMENTS				N/A
Specific area where TOUCH CURRENT measured (i.e., from or between parts of ME SYSTEM within PATIENT ENVIRONMENT)	Allowable TOUCH CURRENT in NORMAL CONDITION (µA)	Measured TOUCH CURRENT in NORMAL CONDITION (µA)	Allowable TOUCH CURRENT in event of interruption of PROTECTIVE EARTH CONDUCTOR, (µA)	Measured TOUCH CURRENT in event of interruption of PROTECTIVE EARTH CONDUCTOR, (µA)	
<b>Supplementary information:</b>					

16.9.1	RM RESULTS TABLE: Connection terminals and connectors			N/A
Clause of ISO 14971	Document Ref. in RMF (Document No. & paragraph)	Result - Remarks		Verdict
4.2				
4.3				
4.4				
5				
6.2				
6.3				
6.4				
6.5				



IEC 60601-1			
Clause	Requirement + Test	Result - Remark	Verdict

17	RM RESULTS TABLE: Electromagnetic compatibility of ME equipment and ME systems		Pass
Clause of ISO 14971	Document Ref. in RMF (Document No. & paragraph)	Result - Remarks	Verdict
4.2	F60-SY-RA-SY-01-REV.I		Pass
4.3	F60-SY-RA-SY-01-REV.I		Pass
4.4	F60-SY-RA-SY-01-REV.I		Pass
5	F60-SY-RA-SY-01-REV.I		Pass
6.2	F60-SY-RA-SY-01-REV.I		Pass
6.3	F60-SY-RA-SY-01-REV.I		Pass
6.4	F60-SY-RA-SY-01-REV.I		Pass
6.5	F60-SY-RA-SY-01-REV.I		Pass

SP	TABLE: Additional or special tests conducted		N/A
Clause and Name of Test	Test type and condition	Observed results	
11.8 Interruption of power supply	The power supply was interrupted – the power cable was disconnected from the UUT	Interruption and restoration of power supply did not result in a hazardous situation, except interruption of its intended function	
<b>Supplementary information:</b>			



IEC 60601-1			
Clause	Requirement + Test	Result - Remark	Verdict

**Attachment 1**  
**ND US+CA**

<b>ATTACHMENT TO TEST REPORT IEC 60601-1</b> <b>US NATIONAL DIFFERENCES</b> <b>Medical electrical equipment, Part 1: General Requirements</b>	
<b>Differences according to</b> .....	US National standard ANSI/AAMI ES60601-1: 2005 / A2:2010
<b>Attachment Form No.</b> .....	US_ND_IEC60601_1G
<b>Attachment Originator</b> .....	Underwriters Laboratories Inc.
<b>Master Attachment</b> .....	2011-04
<b>Copyright © 2011 IEC System for Conformity Testing and Certification of Electrical Equipment (IECEE), Geneva, Switzerland. All rights reserved.</b>	

US NATIONAL DIFFERENCES			-
4.8 b	Replacement: where there was no relevant IEC/ISO standard, the relevant US ANSI standard applied	All parts were evaluated as part of this standard.	N/A
	- when no relevant US ANSI standard existed, the requirements of this standard applied		Pass
4.10.2	Replacement: Rated voltage not exceeding 250V dc or single phase ac. or 600V poly-phase ac for ME EQUIPMENT and ME SYSTEMS up to 4kVA	Not exceed	Pass
	Rated voltage not exceeding 600 V for all other ME EQUIPMENT and ME SYSTEMS		N/A
6.6	Addition: To comply with NFPA 70, X-Ray systems are classified as long time operation (> 5 min) or momentary operation (< 5 sec)	Not x-ray equipment.	N/A
7.2.11	Addition: To comply with NFPA 70, X-Ray systems are marked as long time operation or momentary operation	Not x-ray equipment.	N/A
7.2.21	New Sub-clause: <b>Colors of medical gas cylinders</b>		-
	To comply with NFPA 99: Cylinders containing medical gases and their connection points are colored in accordance with the requirements of NFPA 99	Does not contain medical gases.	N/A
8.2	Addition: All FIXED ME EQUIPMENT & PERMANENTLY INSTALLED ME EQUIPMENT are CLASS I ME EQUIPMENT	No fixed & permanently installed equipment	N/A

IEC 60601-1			
Clause	Requirement + Test	Result - Remark	Verdict
8.6.1	Addition: To comply with NFPA 99, the enclosure of X-ray ME EQUIPMENT operating over 600 Vac, 850Vdc MAINS VOLTAGE, or containing voltages up to 50 V peak and enclosed in protectively earthed enclosure as well as connections to X-ray tubes and other high voltage components that include high voltage shielded cables are PROTECTIVELY EARTHED.	Not x-ray equipment.	N/A
	To comply with NFPA 99, non-current carrying conductive parts of X-Ray ME EQUIPMENT likely to become energized are PROTECTIVELY EARTHED		N/A
8.7.3 d	EARTH LEAKAGE CURRENT values are not higher than the stated values	Class II equipment	N/A
	5 mA in NORMAL CONDITION		N/A
	10 mA in SINGLE FAULT CONDITION		N/A
8.11	Addition prior to the first paragraph: a) To comply with the NEC, add the following requirements to this clause:		-
	Addition: PERMANENTLY CONNECTED ME EQUIPMENT provided with field wiring provision in accordance with NEC	No permanently connected equipment	N/A
	Installation of connecting cords between EQUIPMENT parts comply with NEC		N/A
	Cable used as external interconnection between units		-
	1) Exposed to abuse: Type SJT, SJTO, SJO, ST, SO, STO, or equivalent, or similar multiple-conductor appliance-wiring material,	No external interconnection cables	N/A
	2) Not exposed to abuse: The cable was as in item 1) above, or		N/A
	i) Type SPT-2, SP-2, or SPE-2, or equivalent		N/A
	ii) Type SVr, SVRO, SVE, or equivalent or similar multiple-conductor appliance wiring material,		N/A
	iii) An assembly of insulated wires each with a nominal insulation thickness of 0.8 mm (1/32 inch) or more,		N/A
	- enclosed in acceptable insulating tubing having a nominal wall thickness of 0.8 mm (1/32 inch) or more		N/A
	Receptacles provided as part of ME EQUIPMENT and ME SYSTEMS for use in the patient care areas of pediatric wards, rooms, or areas are Listed		N/A



IEC 60601-1			
Clause	Requirement + Test	Result - Remark	Verdict
	tamper resistant		
	- or employ a Listed tamper resistant cover in accordance with NEC		N/A
	Addition at the end of the clause: b) For ME EQUIPMENT provided with NEMA configuration non-locking plug types 120 V/15 A, 125 V/20 A, 250 V/15 A, 250 V/20 A "Hospital Grade" mains plug is provided and the POWER SUPPLY CORD is marked		N/A
8.11.3.2	Addition: The flexible cord is a type acceptable for the particular application,	No external interconnection cables	N/A
	- and it is acceptable for use at a voltage not less than the rated voltage of the appliance		N/A
	- and has an ampacity as in NEC, not less than the current rating of the appliance		N/A
8.11.3.3	Addition: To comply with NFPA 99, for X-Ray ME EQUIPMENT with an attachment plug, the current rating on a hospital grade plug is 2X the maximum input current of the equipment	Not x-ray equipment.	N/A



IEC 60601-1			
Clause	Requirement + Test	Result - Remark	Verdict

<b>ATTACHMENT TO TEST REPORT IEC 60601-1 3<sup>rd</sup> edition CA - CANADIAN NATIONAL DIFFERENCES to CAN/CSA-C22.2 No. 60601-1:08</b>	
<b>Differences according to</b> .....	Canadian National standard: CAN/CSA-C22.2 No. 60601-1:08
<b>Attachment Form No.</b> .....	CA_ND_IEC60601_1G
<b>Attachment Originator</b> .....	CSA International
<b>Master Attachment</b> .....	2010-12
<b>Copyright © 2010 IEC System for Conformity Testing and Certification of Electrical Equipment (IECEE), Geneva, Switzerland. All rights reserved.</b>	

<b>CA - Canadian National Differences as per CAN/CSA-C22.2 No. 60601-1:08</b>			
1	<b>Scope, object and related documents</b>		---
1.1	<b>Scope</b>		---
	This standard applies to the BASIC SAFETY and ESSENTIAL PERFORMANCE of MEDICAL ELECTRICAL EQUIPMENT and MEDICAL ELECTRICAL SYSTEMS designed to be installed in accordance with the <i>Canadian Electrical Code (CEC), Part I, CSA C22.1; CAN/CSA-C22.2 No. 0; and CAN/CSA-Z32.</i>		Pass
	<b>NOTE 1A:</b> <i>In the IEC 60601 standards series adopted for use in Canada, the Canadian-particular standards may modify, replace, or delete requirements contained in this standard as appropriate for the particular ME EQUIPMENT and ME SYSTEMS under consideration, and may add other BASIC SAFETY and ESSENTIAL PERFORMANCE requirements.</i>		---
1.3	<b>Collateral standards</b>		---
	Applicable Canadian collateral standards become normative at the date of their publication and apply together with this standard.		Pass
	<b>NOTE 1:</b> <i>When evaluating compliance with CAN/CSA-C22.2 No. 60601-1, it is permissible to assess independently compliance with the adopted Canadian collateral standards.</i>		---
1.4	<b>Particular standards</b>		---
	A requirement of a Canadian-particular safety standard takes precedence over this standard.		N/A
3	<b>Terminology and definitions</b>		---
3.41	<b>HIGH VOLTAGE</b>		---
	any voltage above 750 V, 1 050 V peak, as defined in the <i>Canadian Electrical Code (CEC), Part I</i>	No such voltages	N/A

IEC 60601-1			
Clause	Requirement + Test	Result - Remark	Verdict
4	<b>General requirements</b>		---
4.8	<b>Components of ME EQUIPMENT</b>		---
	a) the applicable safety requirements of a relevant CSA, IEC, or ISO standard; or		Pass
	<b>NOTE 1:</b> For the components, it is not necessary to carry out identical or equivalent tests already performed to check compliance with the component standard.		---
	b) where there is no relevant CSA, IEC, or ISO standard, the requirements of this standard have to be applied		Pass
	<b>NOTE 2:</b> If there are neither requirements in this standard nor in a CSA, IEC, or ISO standard, any other applicable source (e.g., standards for other types of devices, national standards) could be used to demonstrate compliance with the RISK MANAGEMENT PROCESS.		---
4.10.2	<b>SUPPLY MAINS for ME EQUIPMENT and ME SYSTEMS</b>		----
	and shall be in accordance with the <i>Canadian Electrical Code (CEC), Part I, CSA C22.1:</i>		Pass
7	<b>ME EQUIPMENT identification, marking and documents</b>		---
7.7.1 to 7.7.5	and shall be in accordance with the <i>Canadian Electrical Code (CEC), Part I, CSA C22.1</i>		Pass
	A PROTECTIVE EARTH CONDUCTOR or a PROTECTIVE EARTH CONNECTION or insulation shall be identified by either green or green and yellow colour. Colours of neutral and POWER SUPPLY CORD conductors shall be in accordance with the <i>Canadian Electrical Code (CEC), Part I, CSA C22.2 No. 21, and CSA C22.2 No. 49.....</i> :	No protective earth, Class II	N/A
8	<b>Protection against electrical HAZARDS from ME EQUIPMENT</b>		---
8.7.3	<b>Allowable values</b>		---
	Allowable values shall be in accordance with the <i>Canadian Electrical Code (CEC), Part I, CSA C22.1.</i>		Pass
8.11.3	<b>POWER SUPPLY CORDS</b>		---
8.11.3.2	<b>Types</b>		---
	a) The MAINS PLUG of non-PERMANENTLY INSTALLED EQUIPMENT shall be		---
	i) if molded-on type, hospital grade mains plug complying with CSA C22.2 No. 21;.....:	Power Supply cord is not part of this investigation, the appropriate type will be provided by the manufacturer to any country it will be sold	Pass

IEC 60601-1			
Clause	Requirement + Test	Result - Remark	Verdict
	ii) hospital grade disassembly attachment plug type complying with CSA C22.2 No. 42; or.....:	No such mains plug	N/A
	iii) Class II equipment having fuses on the line side/sides and neutral and may use a non-polarized attachment plug or a polarized attachment plug — CSA configuration type 1-15P shall be required and shall meet all applicable requirements in CSA C22.2 No. 21 and CSA C22.2 No. 42. Where a polarized attachment plug is used, the POWER SUPPLY CORD shall be connected to the wiring of the EQUIPMENT on the ungrounded side of the line when any of the following devices are used in the primary circuit:.....:		N/A
	1- the centre contact of an Edison base lampholder;		N/A
	2- a single pole switch;		N/A
	3- an automatic control with a marked off position;		N/A
	4- a solitary fuse/fuse holder; or		N/A
	5- any other single pole overcurrent protective device		N/A
	b) Detachable POWER SUPPLY CORD for non-PERMANENTLY INSTALLED EQUIPMENT (cord-connected equipment) shall be of a type that		---
	i) can be shown to be unlikely to become detached accidentally, unless it can be shown that detachment will not constitute a safety HAZARD to a PATIENT or OPERATOR;		Pass
	ii) can be shown that the impedance of the earth (ground) circuit contacts will not constitute a safety HAZARD to a PATIENT or OPERATOR; and	Class II	N/A
	iii) has a terminal configuration or other constructional feature that will minimize the possibility of its replacement by a detachable POWER SUPPLY CORD which could create a HAZARDOUS SITUATION		N/A
	c) A detachable POWER SUPPLY CORD shall		---
	i) comply with the applicable requirements of CSA C22.2 No. 21; and.....:	Power Supply cord is not part of this investigation, the appropriate type will be provided by the manufacturer	N/A
	ii) not be smaller than No. 18 AWG, and the mechanical serviceability shall be not less than.....:		N/A
	1) Type SJ or equivalent for mobile or exposed to abuse ME EQUIPMENT; and.....:		N/A



IEC 60601-1			
Clause	Requirement + Test	Result - Remark	Verdict
	2) Type SV or equivalent for ME EQUIPMENT not exposed to abuse (or Type HPN if required because of temperature).....:		N/A
	<b>NOTE 1A:</b> See CSA C22.2 No. 49 for requirements on the cord types mentioned in Sub-item 2).		---
	d) Power supply cords shall meet the requirements of the <i>Canadian Electrical Code, Part I</i> , as applicable.....:		N/A
	Connecting cords between equipment parts shall meet the requirements of the <i>Canadian Electrical Code, Part I</i> , as applicable.....:		N/A
8.11.5	<b>Mains fuses and OVER-CURRENT RELEASES</b>		---
	Mains fuses and OVER-CURRENT RELEASES shall be in accordance with the <i>Canadian Electrical Code (CEC), Part I, CSA C22.1</i> .....:		Pass
9	<b>Protection against MECHANICAL HAZARDS of ME EQUIPMENT and ME SYSTEMS</b>		---
9.7.5	<b>Pressure vessels</b>		---
	Pressure vessels shall comply with the requirements of CSA B51, as applicable.....:	No pressure being contained.	N/A
9.7.7	<b>Pressure-relief device</b>		---
	A pressure-relief device shall also comply as applicable to the requirements of ASME PTC 25 or equivalent Canadian requirements.....:		N/A
15	<b>Construction of ME EQUIPMENT</b>		---
15.4.1	<b>Construction of connectors</b>		---
	bA) The point of connection of gas cylinders to EQUIPMENT shall be gas specific and clearly identified so that errors are avoided when a replacement is made. Medical gas inlet connectors on EQUIPMENT shall be		---
	i) gas specific, yoke type, or nut and nipple type valve connections complying with CGA V-1 for pressures over 1 380 kPa (200 psi); or.....:	No gas connections with pressure over 200 psi.	N/A
	ii) DISS type complying with CGA V-5 for pressures 1 380 kPa (200 psi) or less and configured to permit the supply of medical gases from low-pressure connecting assemblies complying with CAN/CSA-Z5359.....:		N/A



IEC 60601-1			
Clause	Requirement + Test	Result - Remark	Verdict
	<b>NOTE 1A:</b> Users of this standard should consult the CSA Z305 series of standards, CAN/CSA-Z9170-1, CAN/CSA-Z9170-2, CAN/CSA-Z10524, and CAN/CSA-Z15002 for further information regarding inlet connectors; ISO 407 for requirements addressing yoke-type valve connections; and ISO 32 for colour coding.		---
15.4.8	<b>Internal wiring of ME EQUIPMENT</b>		---
	Internal wiring of ME EQUIPMENT shall be in accordance with the <i>Canadian Electrical Code (CEC), Part I, CSA C22.1</i> .....:		Pass
16	<b>ME SYSTEMS</b>		---
16.1	<b>General requirements for the ME SYSTEMS</b>		---
	An ME SYSTEM shall provide		---
	- within the PATIENT ENVIRONMENT, the level of safety equivalent to ME EQUIPMENT complying with this standard; and	Not defined as system	N/A
	- outside the PATIENT ENVIRONMENT, the level of safety equivalent to equipment complying with their respective CSA, IEC, or ISO safety standards		N/A
	Non-ME EQUIPMENT, when used in an ME SYSTEM, shall comply with CSA, IEC, or ISO safety standards that are relevant to that equipment.		N/A
16.9.2.1	<b>MULTIPLE SOCKET OUTLET</b>		---
	c) The MULTIPLE SOCKET-OUTLET shall comply with the requirements of CSA C22.2 No. 42, CSA C22.2 No. 49, and the following requirements.....:	No multiple socket-outlet	N/A
	- The separating transformer shall comply with the requirements of CAN/CSA-E61558-2-1 with a rated output not exceeding		---
	- 1 kVA for single-phase transformers; and		N/A
	- 5 kVA for polyphase transformers The separating transformer shall also have a degree of protection not exceeding IPX4.		N/A

IEC 60601-1			
Clause	Requirement + Test	Result - Remark	Verdict

**Attachment 2**  
**Photos**



**Fig.1. Front view of Flight 60 Blower**

IEC 60601-1			
Clause	Requirement + Test	Result - Remark	Verdict



**Fig.2. Rear view Flight 60 Blower**

IEC 60601-1			
Clause	Requirement + Test	Result - Remark	Verdict

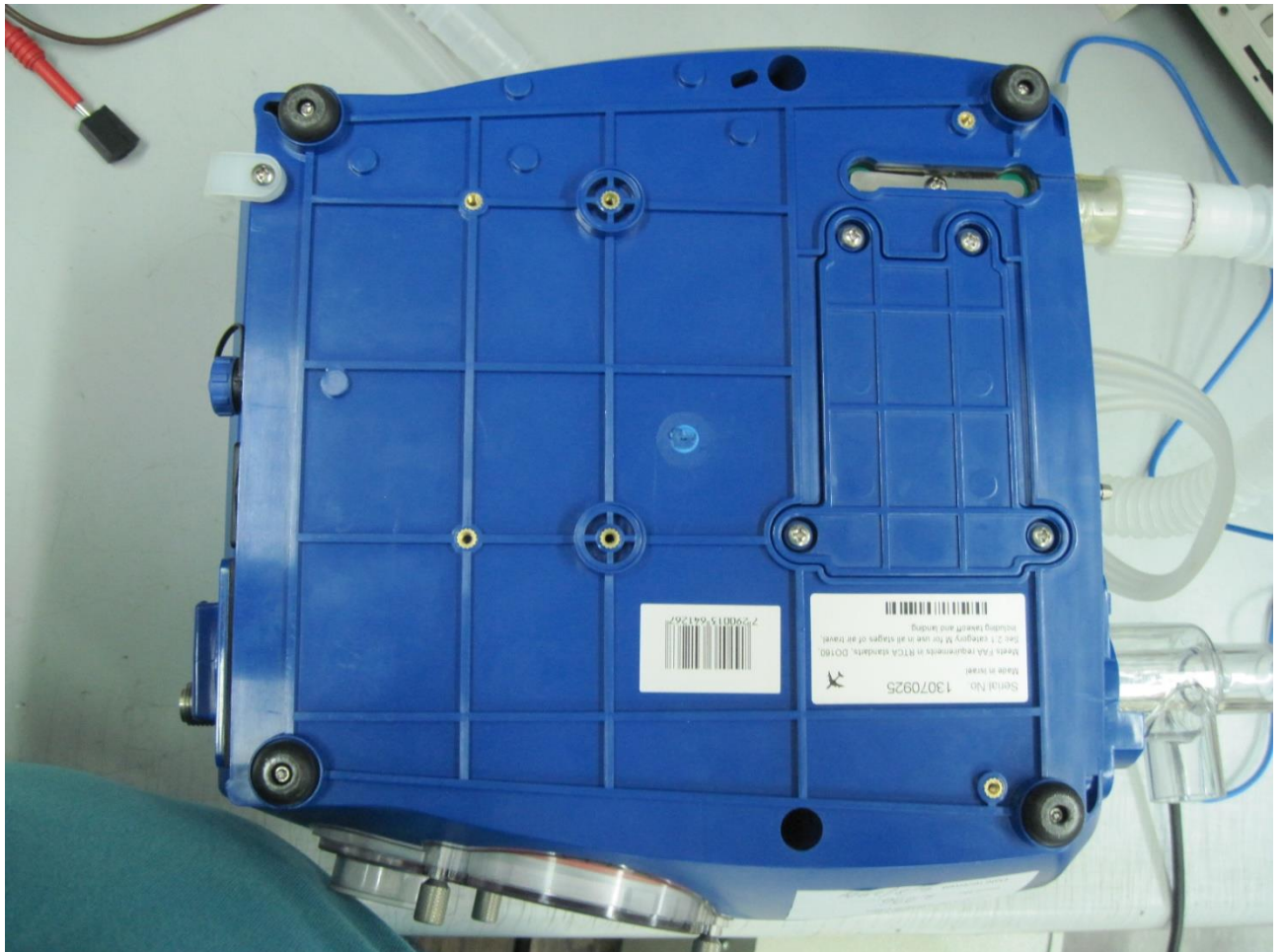

**Fig.3. Bottom view of Flight 60 Blower**

IEC 60601-1			
Clause	Requirement + Test	Result - Remark	Verdict

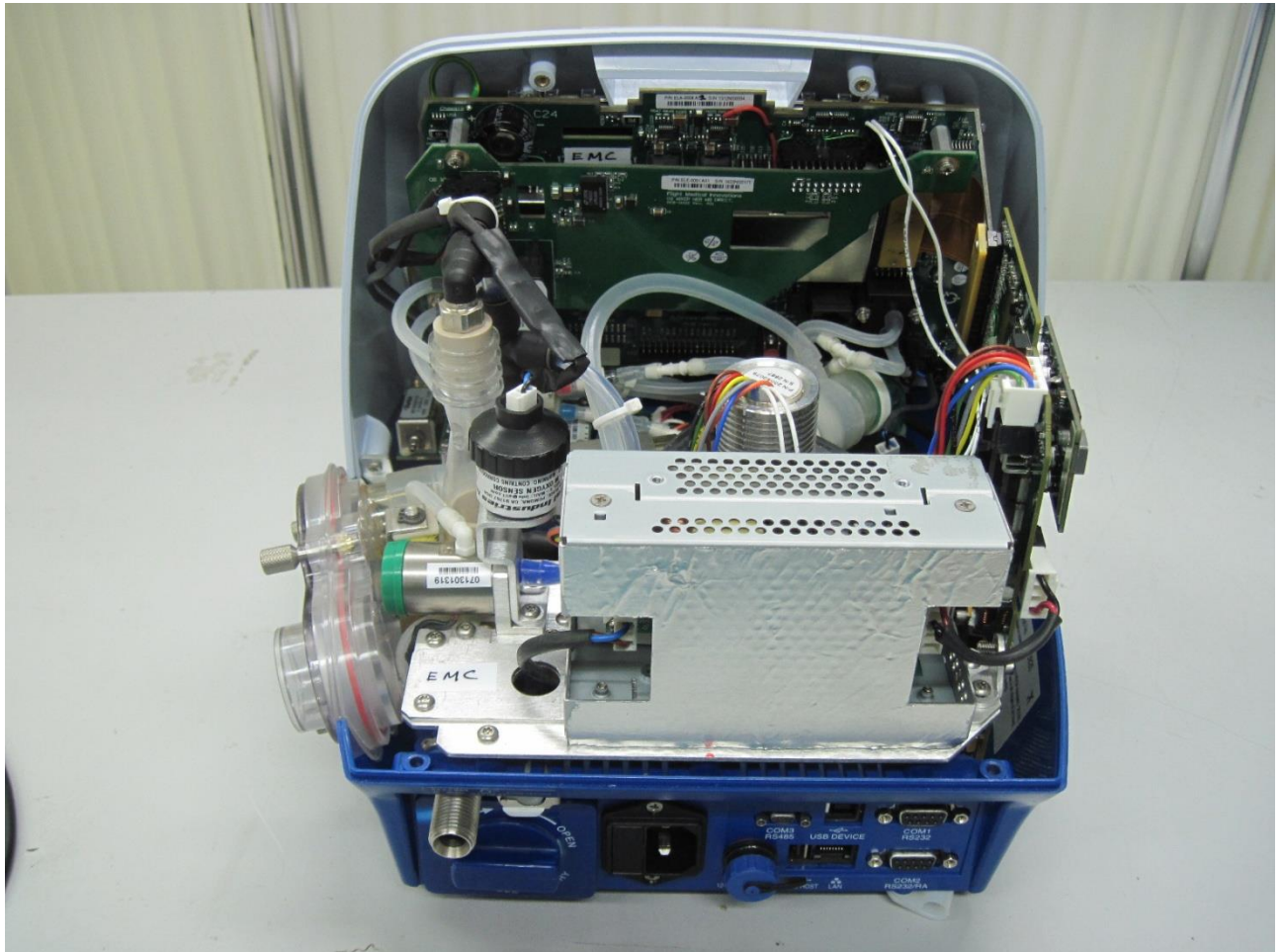

**Fig.4. Internal general view Flight 60 Blower**

IEC 60601-1			
Clause	Requirement + Test	Result - Remark	Verdict



**Fig.5. Internal Right side view (a) Flight 60 Blower**

IEC 60601-1			
Clause	Requirement + Test	Result - Remark	Verdict



**Fig.6. Internal Right side view (b) Flight 60 Blower**

IEC 60601-1			
Clause	Requirement + Test	Result - Remark	Verdict



**Fig.7. Internal Left side view (a) Flight 60 Blower**

IEC 60601-1			
Clause	Requirement + Test	Result - Remark	Verdict

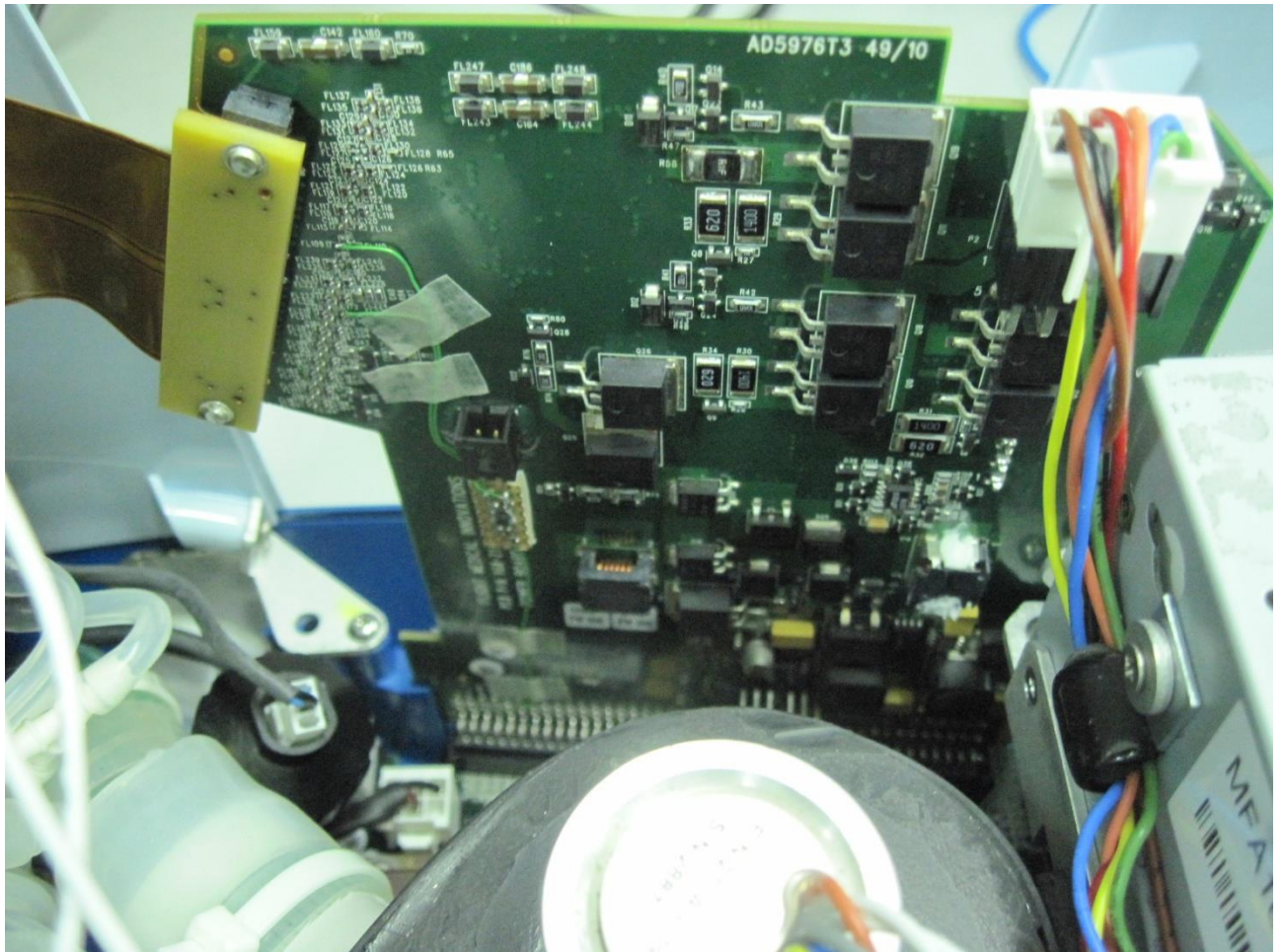
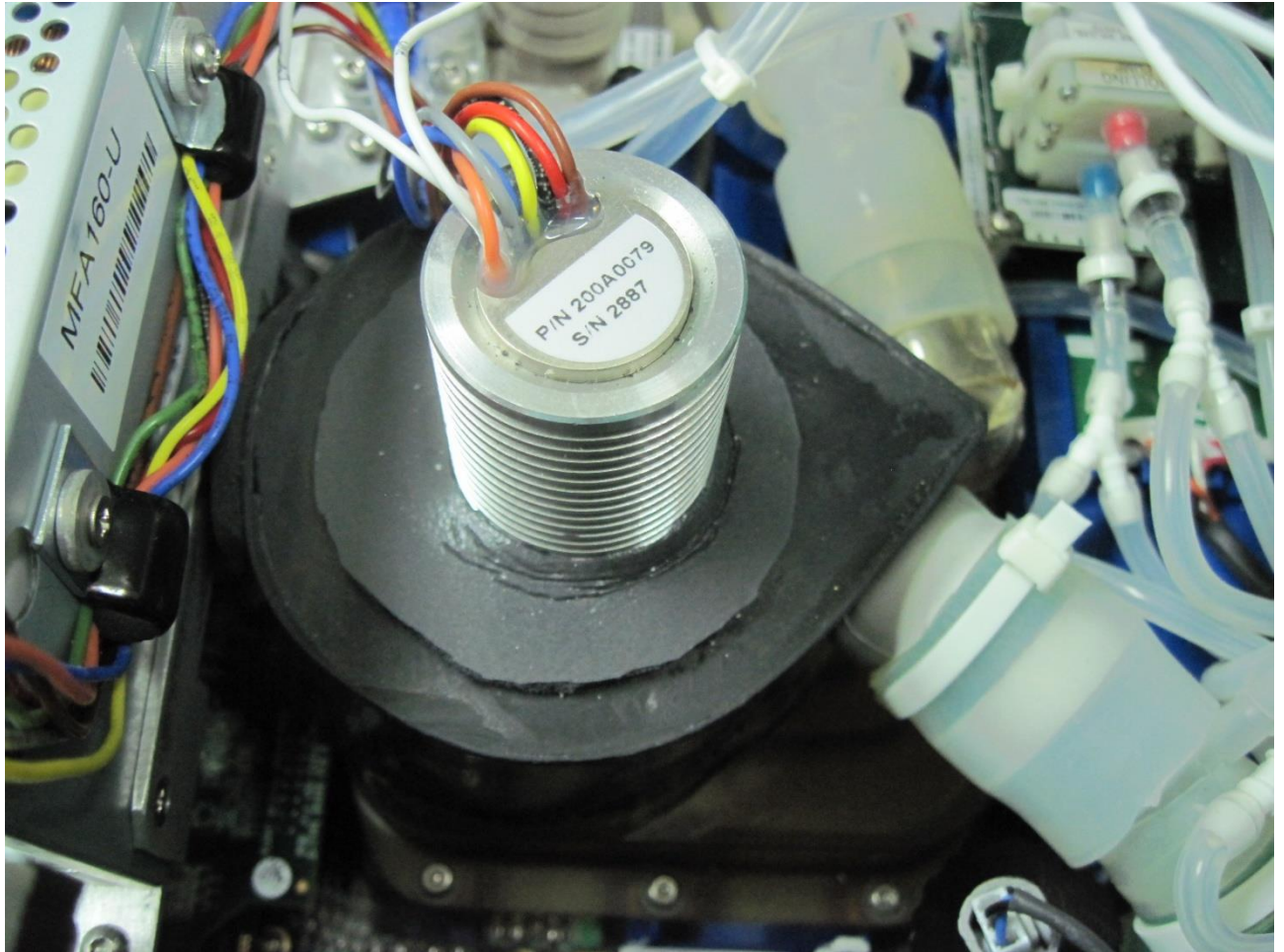

Fig.8. Internal Left side view (b) Flight 60 Blower

IEC 60601-1			
Clause	Requirement + Test	Result - Remark	Verdict



**Fig.9. Internal Blower view Flight 60 Blower**

IEC 60601-1			
Clause	Requirement + Test	Result - Remark	Verdict

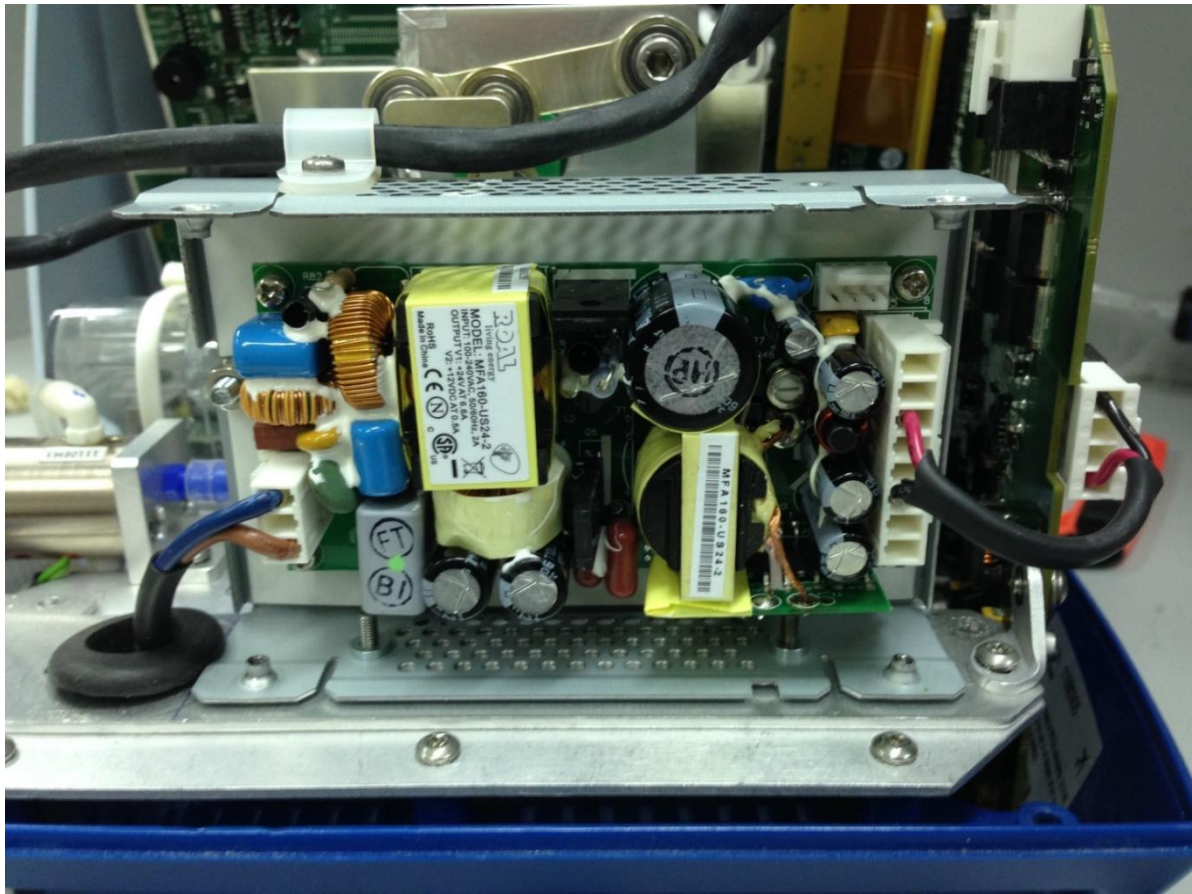
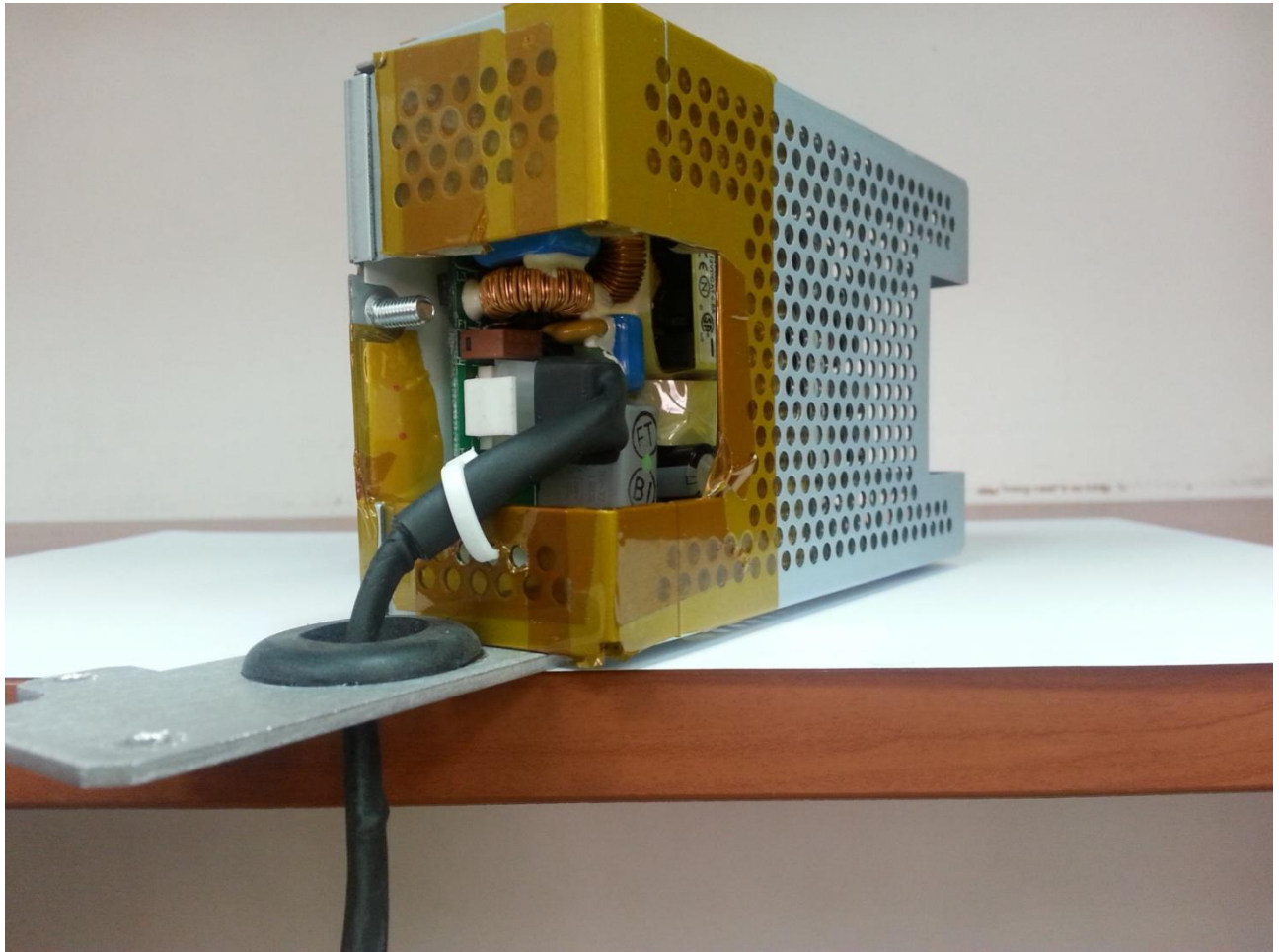

Fig.10. AC/DC PSU for Flight 60 Blower

IEC 60601-1			
Clause	Requirement + Test	Result - Remark	Verdict



**Fig.11. AC/DC PSU (AC connection) for Flight 60 Blower**

IEC 60601-1			
Clause	Requirement + Test	Result - Remark	Verdict



Fig.12. AC inlet for Flight 60 Blower



Fig.13. Battery Pack Detachable For Flight 60 Blower

IEC 60601-1			
Clause	Requirement + Test	Result - Remark	Verdict



**Fig.14. Battery Pack Integral for Flight 60 (Blower)**

IEC 60601-1			
Clause	Requirement + Test	Result - Remark	Verdict



**Fig.15. DC Power Cable for Flight 60 Blower**

IEC 60601-1			
Clause	Requirement + Test	Result - Remark	Verdict

**Attachment 3**  
**DC cable data**

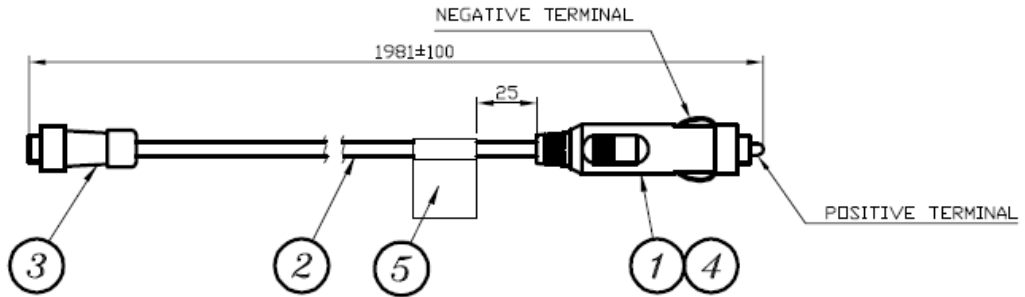

5	V60-60041-18	1	CAUTION STICKER	
4		1	FUSE 8A SLOW BLOW	LITTELFUSE OR EQUIVALENT UL RECOGNIZED/ APPROVED
3	SP1310S2	1	CONNECTOR	WEIPU
2		1930mm	DC CORD, 18AWG, 2 HOOK-UP WIRES, PVC, 300V, DOUBLE ISOLATION	UL RECOGNIZED/ APPROVED
1	APP 003	1	CIGARETTE LIGHTER PLUG	MEMORY PROTECTION DEV. OR EQUIVALENT

**End of Test Report**